

A photograph of a modern, multi-story building at dusk. The building has a clean, minimalist design with large glass windows and balconies. The interior lights are on, creating a warm glow. In the foreground, there is a swimming pool with a tiled edge, reflecting the building and the sky. The sky is a deep blue, indicating twilight. The overall atmosphere is sophisticated and contemporary.

03 | MULTISPLIT
FREEMATCH

Freematch



Compact Design



Up To 5



Big Family



New Path Design



Outstanding construction with different installation options

Compact Design

Lighter and more compact units for easy installation, flexible installation location, larger packing volume and various transportation.

Note: Hisense has the most compact 1 by 2 multi-split outdoor unit model in class.

Individually controlled indoor units all connected to one outdoor unit

Freematch Up To 5

One Freematch outdoor unit can be matched with up to 5 different types of indoor unit and each indoor unit can be individually controlled.

Note: Refer to the Freematch match table for more information.

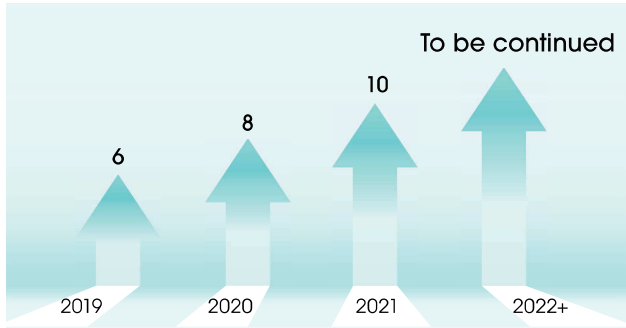

Different expansion and upgrade options

Big Family

We will be having 10 models of R32 Freematch on sale in 2021, which can provide customers with more choices. And this family are all DC so that they can be used in 50Hz or 60Hz countries and regions.

Capacity range: 3500W ~ 12500W

Match range: 1 by 2 ~ 1 by 5

High efficiency and ice block prevention

New Path Design



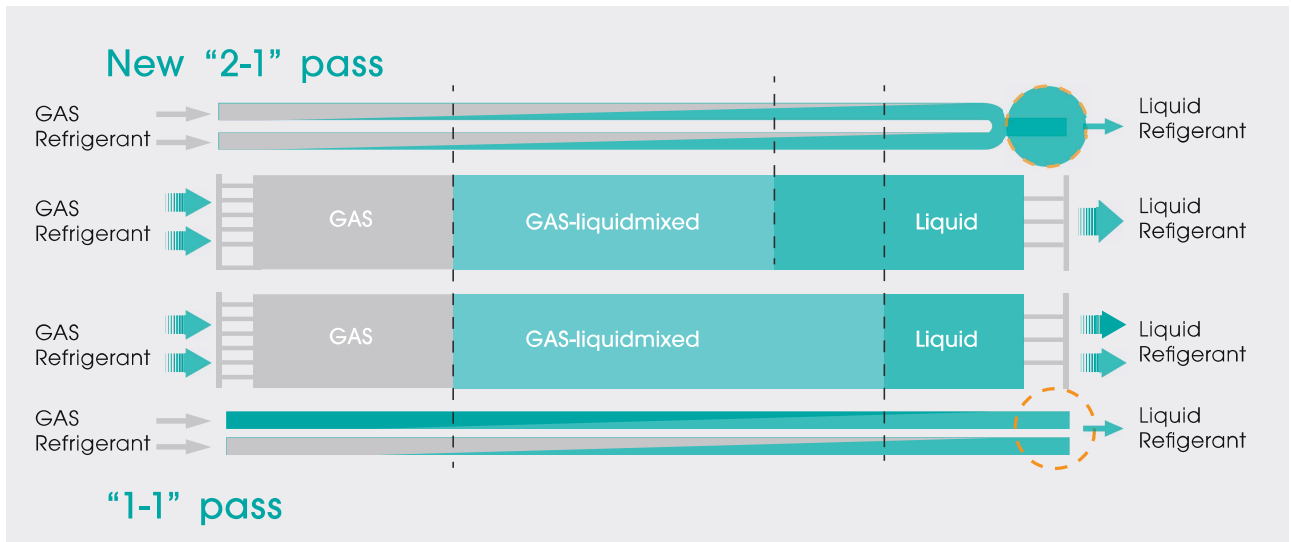

Reverse path design improves efficiency of exchanger greatly. At the rear of the path are super cooling paths, which can improve the cooling capacity and add the length of pipes between indoor and outdoor units. While it is running heating mode, this can prevent base pan from ice block.



Line up

| FM Super R32 Inverter



	Model		Up to		Power
	2AMW35U4RRA 2AMW42U4RRA 2AMW50U4RXA	→	2	→	3.5kW, 4.2kW, 5.2kW
	3AMW42U4RJA 3AMW52U4RJA 3AMW62U4RFA 3AMW72U4RFA	→	3	→	4.2kW, 5.2kW, 6.0kW, 7.2kW
	4AMW81U4RAA 4AMW105U4RAA	→	4	→	8.1kW, 10.5kW
	5AMW125U4RTA	→	5	→	12.5kW

Technical specifications

Freematch ODU



FM Super R32 Inverter

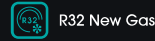

R32 New Gas

Leakage
Detective

Pump Down

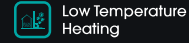
Cooling at
-15°C (5°F)Low Temperature
Heating

Easy Installation

Intelligent
Defrost

Spacing Saving



Service Checker

Model		2AMW35U4RRA	2AMW42U4RRA	2AMW50U4RXA	3AMW42U4RJA	3AMW52U4RJA
Matching Indoor Units		Up to 2	Up to 2	Up to 2	Up to 3	Up to 3
Nominal Cooling	W	3500	4100	5200	4200	5500
Nominal Heating	W	3850	4500	6000	5500	6300
SEER	W / W	6,60	6,60	7,20	7,50	7,30
SCOP	W / W	4,12	4,10	4,10	4,05	4,05
Energy Efficiency Class / Cooling		A++	A++	A++	A++	A++
Energy Efficiency Class / Heating		A+	A+	A+	A+	A+
EER	W / W	4,12	4,10	3,77	4,38	4,23
COP	W / W	4,53	4,50	4,20	4,23	3,94
Outdoor Unit (W x H x D)	mm	730 x 540 x 260	730 x 540 x 260	810 x 580 x 280	860 x 670 x 310	860 x 670 x 310
Diameter (Liquid)	mm	6,35 x 2	6,35 x 2	6,35 x 2	6,35 x 3	6,35 x 3
Diameter (Gas)	mm	9,52 x 2	9,52 x 2	9,52 x 2	9,52 x 3	9,52 x 3
Power Supply	Outdoor Source	220-240V~50/60Hz Outdoor Supply	220-240V~50/60Hz Outdoor Supply	220-240V~50/60Hz Outdoor Supply	220-240V~50/60Hz Outdoor Supply	220-240V~50/60Hz Outdoor Supply

Model		3AMW62U4RFA	3AMW72U4RFA	4AMW81U4RAA	4AMW105U4RAA	5AMW125U4RTA
Matching Indoor Units		Up to 3	Up to 3	Up to 4	Up to 4	Up to 5
Nominal Cooling	W	6300	7200	8000	10000	12500
Nominal Heating	W	7200	7920	9000	11000	13500
SEER	W / W	6,90	6,80	7,01	6,50	-
SCOP	W / W	4,01	4,01	4,05	4,01	-
Energy Efficiency Class / Cooling		A++	A++	A++	A++	-
Energy Efficiency Class / Heating		A+	A+	A+	A+	-
EER	W / W	4,29	3,85	3,56	3,23	3,46
COP	W / W	4,04	3,90	4,00	3,93	3,56
Outdoor Unit (W x H x D)	mm	860 x 670 x 310	860 x 670 x 310	950 x 840 x 340	950 x 840 x 340	950 x 1050 x 340
Diameter (Liquid)	mm	6,35 x 3	6,35 x 3	6,35 x 4	6,35 x 4	6,35 x 5
Diameter (Gas)	mm	9,52 x 3	9,52 x 3	9,52 x 4	9,52 x 4	9,52 x 5
Power Supply	Outdoor Source	220-240V~50/60Hz Outdoor Supply	220-240V~50/60Hz Outdoor Supply	220-240V~50/60Hz Outdoor Supply	220-240V~50/60Hz Outdoor Supply	220-240V~50/60Hz Outdoor Supply

RAC IDU



WiFi Control

ON/ OFF
FunctionRoom Card
ControlFire Leakage
ControlVertical
Auto SwingHorizontal
Auto Swing

Dimmer

Self-diagnosis
Protection

Universal Unit

Model Name		DJ25VE0BG	DJ35VE0BG	DJ50XA0BG	DJ70BB0CG
Nominal Cooling	W	2600	3500	5000	7000
Nominal Heating	W	2800	4000	5600	7100
Input-Cooling	W	45	44	70	52
Input-Heating	W	45	44	70	52
Air Circulation	m ³ / h	550	600	1000	1100
Sound Pressure (H / M / L)	dB (A)	38/ 34/ 26	38/ 34/ 28	44/ 40/ 33	45/ 40/ 35
Net Dimension (W x H x D)	mm	815 x 270 x 212	815 x 270 x 212	915 x 315 x 235	1085 x 315 x 235
Net Weight	kg	8,5	8,5	12	13
Package Dimension (W x H x D)	mm	870 x 335 x 265	870 x 335 x 265	1000 x 390 x 315	1170 x 390 x 315
Gross Weight	kg	11	11	14	16
Liquid Pipe	mm	6,35	6,35	6,35	9,52
Gas Pipe	mm	9,52	9,52	12,7	15,88
Power Supply	Indoor Source	220-240V~50/60Hz Outdoor Supply	220-240V~50/60Hz Outdoor Supply	220-240V~50/60Hz Outdoor Supply	220-240V~50/60Hz Outdoor Supply

Cassette IDU



WiFi Easy

ON/ OFF
FunctionRoom Card
ControlFire Leakage
ControlVertical
Auto Swing

High Ceiling

Fresh Air
IntakeSilver
Ion Filter

Universal Unit

Model Name		ACT26UR4RCA4	ACT35UR4RCA4	ACT52UR4RCA4
Nominal Cooling	W	2840	3750	5200
Nominal Heating	W	3130	4000	5900
Input-Cooling	W	22	35	41
Input-Heating	W	22	35	41
Air Circulation	m ³ / h	500	600	700
Sound Pressure (H / M / L)	dB (A)	33/ 30/ 27	35/ 32/ 29	37/ 34/ 30
Net Dimension (W x H x D)	mm	570 x 215 x 570	570 x 215 x 570	570 x 215 x 570
Net Weight	kg	15	15	16
Package Dimension (W x H x D)	mm	730 x 668 x 292	730 x 668 x 292	730 x 668 x 292
Gross Weight	kg	18	18	19
Liquid Pipe	mm	6,35	6,35	6,35
Gas Pipe	mm	9,52	9,52	12,7
Power Supply	Indoor Source	220-240V~50/60Hz Outdoor Supply	220-240V~50/60Hz Outdoor Supply	220-240V~50/60Hz Outdoor Supply

Technical specifications

Duct IDU



WiFi Control

ON/ OFF Function

Room Card Control

Fire Leakage Control

Water Level Switch

Built-in Drain Pump

Slim Design

Filter Clean Signal

Universal Unit

FM Super R32 Inverter

Model Name		ADT26UX4RBL4	ADT35UX4RBL4	ADT52UX4RCL4
Nominal Cooling	W	2900	3520	5300
Nominal Heating	W	3100	3800	5800
Input-Cooling	W	22	25	32
Input-Heating	W	22	25	32
Air Circulation	m ³ / h	520	600	900
Sound Pressure (H / M / L)	dB (A)	32/ 29/ 27	36/ 33/ 30	41/ 37/ 33
Net Dimension (W x H x D)	mm	910 x 190 x 445	910 x 190 x 447	1180 x 190 x 445
Net Weight	kg	18	18	30
Package Dimension (W x H x D)	mm	1080 x 285 x 565	1080 x 285 x 565	1350 x 285 x 565
Gross Weight	kg	21,5	21,5	35
Liquid Pipe	mm	6,35	6,35	6,35
Gas Pipe	mm	9,52	9,52	12,7
Power Supply	Indoor Source	220-240V~50/60Hz	220-240V~50/60Hz	220-240V~50/60Hz
	Outdoor Supply	Outdoor Supply	Outdoor Supply	Outdoor Supply

Ceiling & Floor IDU Console IDU



WiFi Control

ON/ OFF Function

Room Card Control

Fire Leakage Control

Slim Design

Universal Unit

FM Super R32 Inverter

Model Name		AKT26UR4RK4	AKT35UR4RK4	AKT52UR4RK4	AVT52UR4RA4
Nominal Cooling	W	2950	3520	5000	5280
Nominal Heating	W	3050	3800	5100	5600
Input-Cooling	W	22	25	35	38
Input-Heating	W	22	25	35	38
Air Circulation	m ³ / h	520	600	700	800
Sound Pressure (H / M / L)	dB (A)	39/ 33/ 28	38/ 35/ 33	44/ 40/ 35	41/ 37/ 34
Net Dimension (W x H x D)	mm	700 x 630 x 220	700 x 630 x 220	700 x 630 x 220	990 x 230 x 680
Net Weight	kg	15	15	15	29
Package Dimension (W x H x D)	mm	840 x 730 x 340	840 x 730 x 340	840 x 730 x 340	1100 x 350 x 820
Gross Weight	kg	19	19	19	34
Liquid Pipe	mm	6,35	6,35	6,35	6,35
Gas Pipe	mm	9,52	9,52	9,52	12,7
Power Supply	Indoor Source	220-240V~50/60Hz	220-240V~50/60Hz	220-240V~50/60Hz	220-240V~50/60Hz
	Outdoor Supply	Outdoor Supply	Outdoor Supply	Outdoor Supply	Outdoor Supply

Installation Drawings

2AMW35U4RRA
2AMW42U4RRA

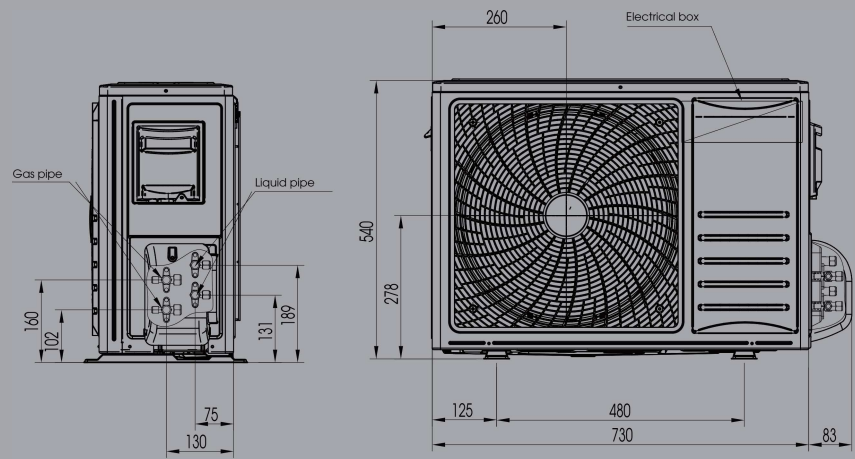

2AMW50U4RXA

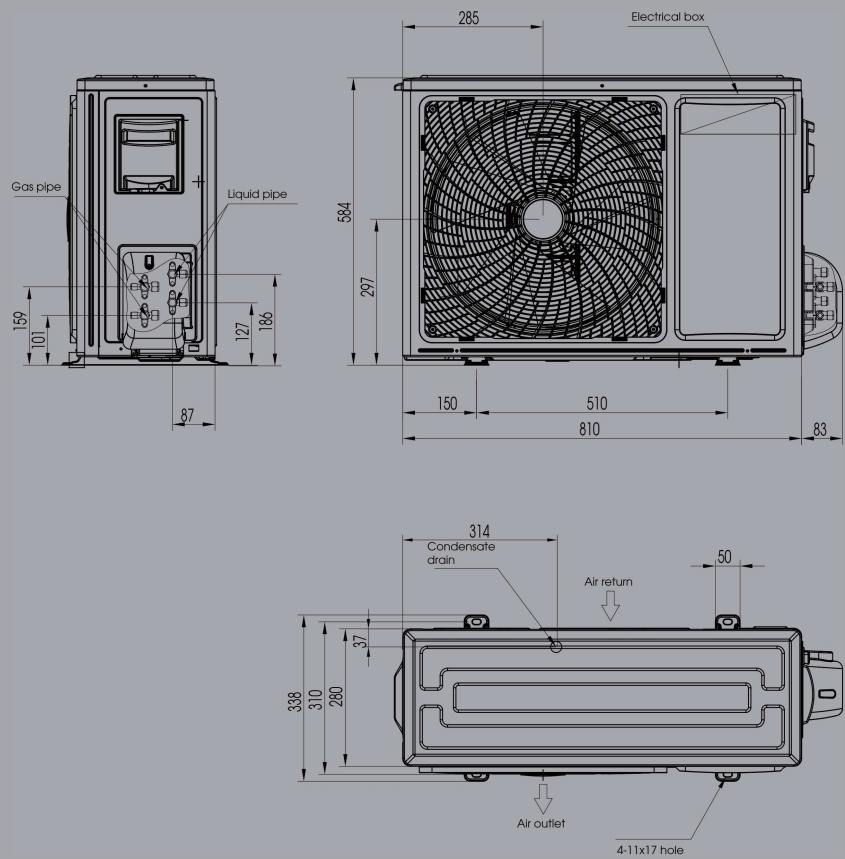

Installation Drawings

3AMW42U4RJA
3AMW52U4RJA

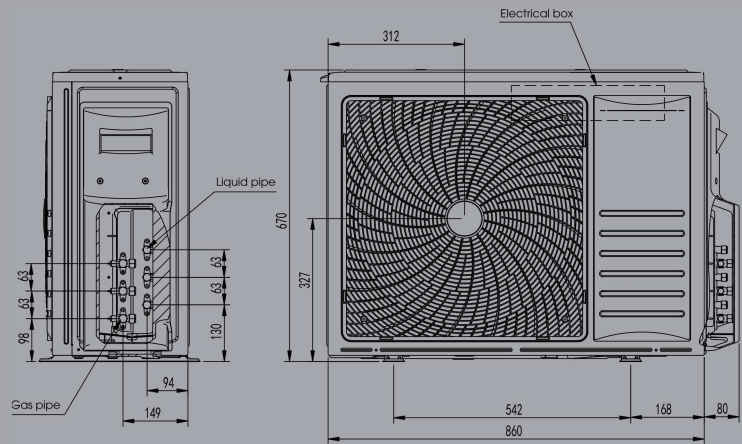

3AMW62U4RFA
3AMW72U4RFA

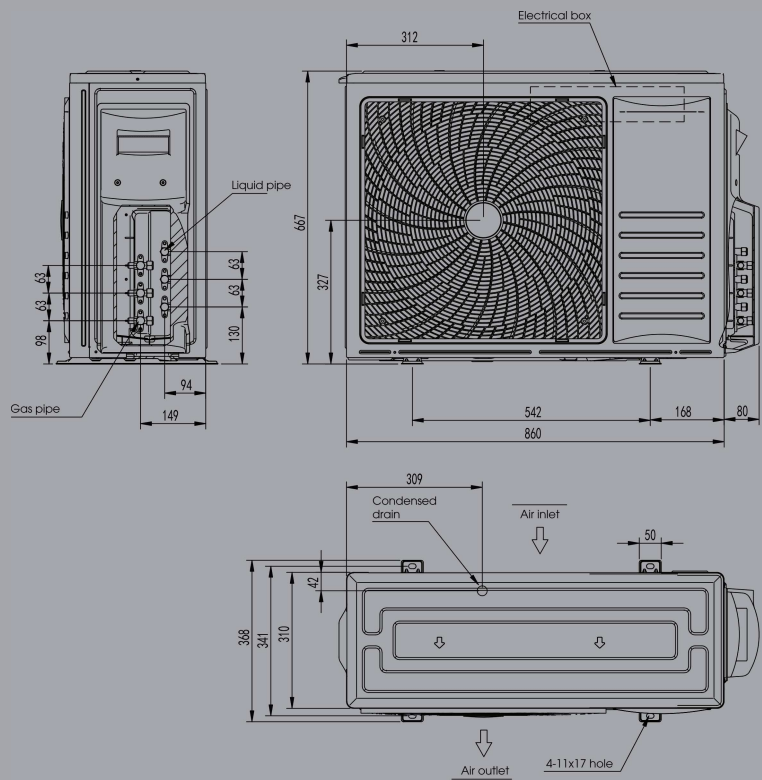

4AMW81U4RAA
4AMW105U4RAA

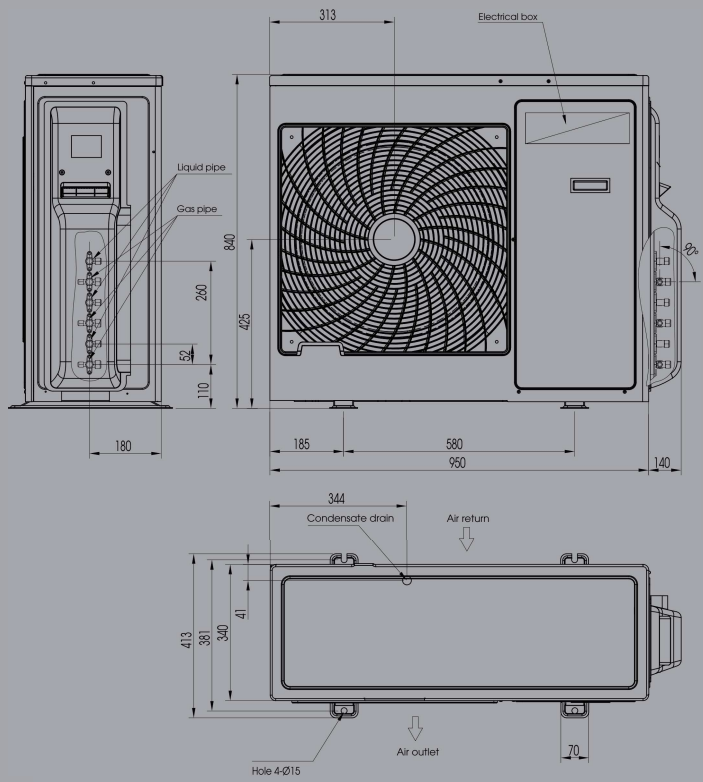

5AMW125U4RTA

