

# Panasonic

## GAS HEAT PUMP ECO G RANGE 2014 - 2015

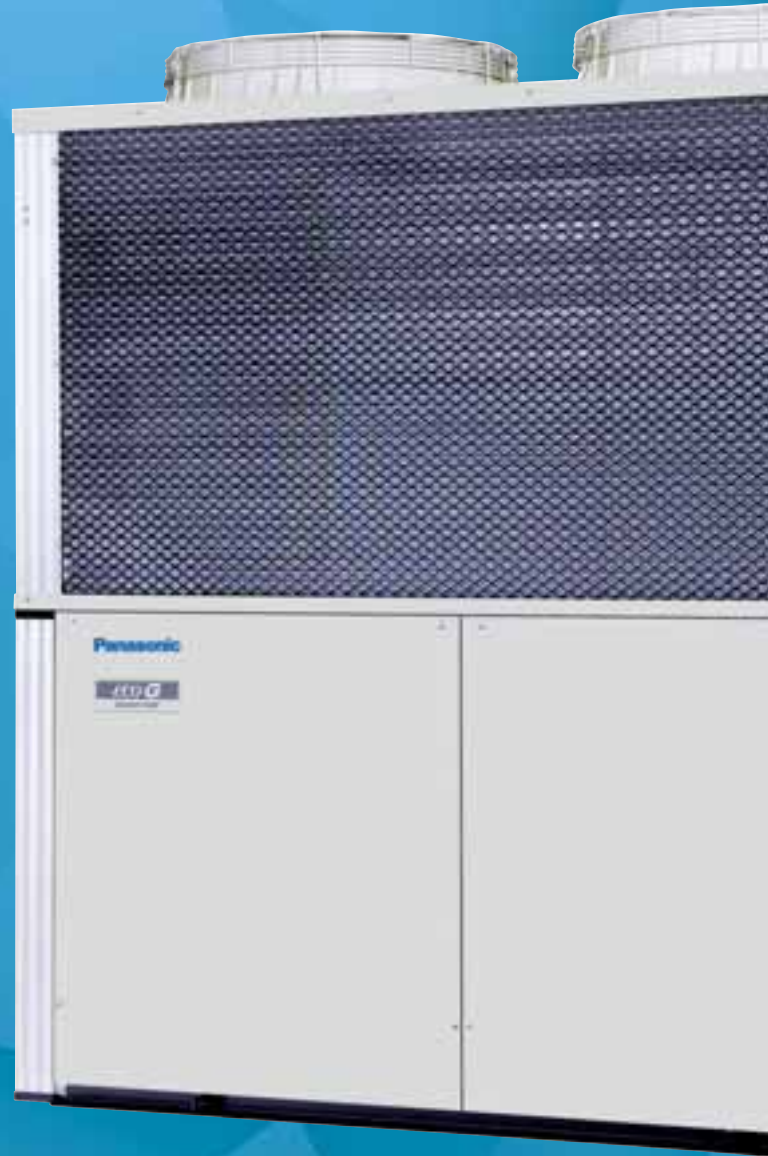

ECO G



INDOOR UNITS

NEW GHP SYSTEMS 2014 - 2015

# NEW 2014 / 2015

## VRF SYSTEMS ECO G RANGE

### Summary

HISTORY OF AIR CONDITIONING GROUP .....	4
PANASONIC – LEADING THE WAY IN HEATING & COOLING .....	5
RELIABILITY FACTS.....	6
PANASONIC EUROPE ANNOUNCES SUSTAINABILITY DECLARATION .....	8
EXEMPLARY SUSTAINABLE PROJECTS .....	9
PRO CLUB: THE PROFESSIONAL WEBSITE OF PANASONIC .....	10
<b>PANASONIC INTRODUCING THE GAS DRIVEN VRF.....</b>	<b>12</b>
ECO G OUTDOOR UNITS RANGE.....	14
ECO G HIGH POWER, ECO G AND ECO G MULTI TECHNOLOGY .....	15
ECO G WATER HEAT EXCHANGER FOR HYDRONIC APPLICATIONS.....	18
ECO G HIGH POWER.....	20
ECO G AND ECO G MULTI .....	22
ECO G 3 WAY .....	24

<b>INDOOR UNITS FOR ECO G .....</b>	<b>26</b>
ECO G SYSTEMS INDOOR UNITS RANGE.....	28
U1 TYPE 4 WAY 90X90 CASSETTE SEMI CONCEALED CASSETTE.....	30
Y2 TYPE 4 WAY 60X60 CASSETTE MINI SEMI CONCEALED CASSETTE .....	31
L1 TYPE 2 WAY CASSETTE.....	32
D1 TYPE 1 WAY CASSETTE .....	33
F2 TYPE VARIABLE STATIC PRESSURE HIDE AWAY.....	34
M1 TYPE SLIM VARIABLE STATIC PRESSURE HIDE AWAY CONCEALED DUCT.....	35
E2 TYPE HIGH STATIC PRESSURE HIDE AWAY.....	36
HEAT RECOVERY WITH DX COIL .....	37
T2 TYPE CEILING .....	38
K2/K1 TYPE WALL MOUNTED .....	39
P1 TYPE FLOOR STANDING .....	40
R1 TYPE CONCEALED FLOOR STANDING.....	41
CONTROL SYSTEMS FOR ECO G.....	42



**Quality Management System Certificate**



**Certified to ISO 9001: 2008**  
Panasonic Appliances Air-Conditioning  
Malaysia. Sdn.Bhd.  
Cert. No.: MY-AR 1010



**Certified to ISO 9001: 2008**  
Panasonic Appliances Air-Conditioning  
(GuangZhou) Co., Ltd.  
Registration Number: 01209Q20645R5L

**Environmental Management System Certificate**



**Certified to ISO 14001: 2004**  
Panasonic Appliances Air-Conditioning  
Malaysia Sdn.Bhd.  
Cert. No.: MY-ER0112



**Certified to ISO 14001: 2004**  
Panasonic Appliances Air-Conditioning  
(GuangZhou) Co., Ltd.  
Registration Number: 02110E10562R4L

# NEW

New 1,5kW indoor units. This new indoor unit is the perfect solution for small rooms or low consumption buildings requiring low energy to heat or cool the space.

PG 26



# NEW

New Remote Controller touch screen with power consumption monitor.

PG 42



# NEW

New indoor unit Hotel Remote control which integrates direct connection to: Card switch, lighting, Window contact and blinds.

PG 42



# NEW

GHP + WHE heating, cooling and DHW. The ECO G the efficient solution for gas boiler replacement.

PG 18



# NEW

New Heat Recovery with DX coil with purifying system Bioxygen®. Increase efficiency of the installation while renewing the air.

PG 37

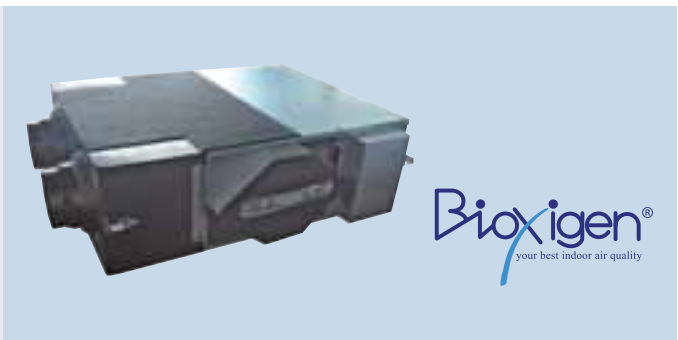

## **A Better Life, A Better World**

As we move towards our Centenary in 2018, our new brand slogan encapsulates Panasonic's vision of expanding and pursuing a better life for each of our customers. Working with our many partners, we operate in a wide range of fields such as the home, community, business, travel, realising a better world globally through its contribution to the environment and other activities, in both its B2C and B2B businesses.





## History of Air Conditioning Group

Panasonic starts with a desire to create things of value. As hard work and dedication results in one innovative product after another, the fledgling company takes its first steps towards becoming the electronics giant of today.



**1936**  
First electric Fan with Automatic Oscillation (36 cm table top model).



**1958**  
First room air conditioner launched for domestic installation. Prior to this date, air conditioners were large and only for commercial use. Panasonic developed the first compact air conditioner for windows; it was lightweight and easy to install, improving the quality of life in Japanese homes. 1,100 units were sold in Japan in the first year, and just two years later, in 1960, this figure rose to 230,000.



**1973**  
Panasonic launches the first highly efficient air-to-water heat pump in Japan.



**1975**  
Panasonic becomes the first Japanese air conditioner manufacturer in Europe.



**2008**  
Etherea new concept of air conditioning systems: high efficiency and high performances with a great design. Etherea also includes a very innovative air quality sensor and air purifier in order to enjoy healthy air at home at all times.



**2010**  
New Aquarea. Panasonic has created Aquarea, an innovative new, low-energy system, designed to help you enjoy ideal temperatures and hot water in your home, even with extreme outdoor temperatures. Aquarea cools or heats to ensure maximum comfort. Aquarea is far cleaner, safer, cheaper and environmentally friendly than alternatives using gas, oil and other electrical systems.



**2011**  
New Eco i VRF solution. The new Panasonic VRF solution for big buildings is the most efficient in the industry in more than 74% of combinations. ECO i satisfies the most demanding standards required by design offices, architects, owners and installers.



**2012**  
New GHP units. Panasonic's gas-driven VRF systems are ideal for projects where power restrictions apply. In 2012, Panasonic extends the Gas Heat Pump range with a new GHP line-up, new GHP G Power (electricity production) and the new Chiller Units.



**2013**  
New ECOi 3-pipes. The best efficiency for your building. Our New 6 Series 3-pipes is achieving a COP of 4.77 at full load, and even more when recovering heat from the building. There is no doubt, Panasonic is reducing environmental impact!



**2014**  
New Aquarea 16kW T-CAP. Improvements deliver impressive, high efficiencies at low ambient temperatures. T-CAP stands for Total Capacity and is capable of maintaining the same nominal capacity even at -15°C without the help of an electric booster heater. Ideal for retrofit and commercial applications.



# 100%

## Panasonic

PRODUCTION 100% PANASONIC  
TESTING AND QUALITY ASSURANCE  
RESEARCH & DEVELOPMENT AND DESIGN  
SERVICE PROVIDER

## Panasonic – leading the way in Heating & Cooling

With more than 30 years of experience, selling to more than 120 countries around the world, Panasonic is unquestionably one of the leaders in the heating and cooling sector.

With a diverse network of production and R&D facilities, Panasonic delivers innovative products incorporating cutting-edge technologies that set the standard for air conditioners worldwide.

Expanding globally, Panasonic provides superior international products transcending borders.

## 100% Panasonic: we control the process

The company is also a world leader in innovation as it has filed more than 91,539 patents to improve its customers' lives. Moreover, Panasonic is determined to remain at the forefront of its market. In all, the company has produced more than 200 million compressors and its products are manufactured in 294 plants which are located all over the world. You can be assured of the extremely high quality of Panasonic's heat pumps. This wish to excel has made Panasonic the international leader in heating and turn-key air conditioning solutions for homes, medium-sized buildings such as offices and restaurants, and large-scale buildings. These offer maximum effectiveness, comply with the strictest environmental standards and meet the most avant-garde construction requirements of our time. At Panasonic we know what a great responsibility it is to install heating and cooling systems. Because offering you the best solutions in heating and cooling matters



## RELIABILITY FACTS

### Reliable comfort comes from reliable technologies

Today, Panasonic air conditioners have earned widespread acclaim throughout the world. A rugged design ensures that the air conditioner will continue to keep the room comfortable, and operate trouble-free for many years. Panasonic believes this is the true value of an air conditioner. And this is why we subject them to a wide range of stringent tests.

Durability. 10,000 Hour Continuous Operation Simulation.



#### Long-term Durability Test

The air conditioner's main mission is to provide a level of durability that allows it to operate reliably for years. In order to achieve this, we conduct an accelerated test for 10,000 hours of continuous operation. The results of this test, which is conducted under conditions that are much more severe than actual operating conditions, prove the rugged strength of Panasonic air conditioners.



#### Compressor Disassembly Test

After a test with 10,000 hours of continuous operation, we remove the compressor from a randomly selected outdoor unit, disassemble it, then examine the internal mechanisms and parts for possible failure. Panasonic air conditioners continue to provide their designed performance for many years even after prolonged operation under harsh conditions.



#### Operating Test in Harsh Conditions

In addition to normal operating conditions, an operating durability test is conducted in a high-temperature, high humidity test chamber at a temperature of 55 °C. For use in cold climates, the test is also conducted in a low temperature test chamber at -20 °C. This test assures that the oil inside the compressor will not freeze during use and interrupt operation.



Checking the oil inside the compressor under extremely cold conditions.



#### Waterproof Test

The outdoor unit, which is subjected to rain and wind, is provided with IPX4 waterproof compliance. Contact sections on printed circuit boards are also resin-potted to prevent adverse effects caused by an unlikely exposure to droplets of water.



A resin-potted circuit board.





**Shock Resistance**

Panasonic simulates impacts, vibrations and other environmental conditions that air conditioners might be subjected to during transport. We promise that the quality and performance at the time of the final product inspection are unchanged when the product reaches the user's home.

No Breaking. When Dropped onto Sides or Corners.



**Drop Test**

Even with the large impacts that may occur due to improper handling during transportation, the product packaging has been strengthened to prevent it from being damaged. In addition to conventional vertical dropping, more severe conditions in which the sides or corners hit the floor first are carefully tested to ensure that the product's rigidity and shock-absorbing materials work to prevent problems.



**Vibration Test**

Preventing damage that would hinder the product's performance due to vibration during transport is a major role of the packaging. Panasonic confirms that the product operates properly even after applying vibrations in both horizontal and vertical directions.



**Warehouse Storage Test**

During distribution, products may be subjected to extended warehouse storage under unfavourable conditions. To simulate these conditions, we place a weight equal to a stack of five product packages on top of the test package, and leave it in that condition in a room at a temperature of 27°C and a humidity level of 85%. Then, the product is checked for proper operation.



**Comfort**

Air conditioners should keep each person in the room comfortable without making their presence known. They should work totally in the background, using their strength to create and maintain a comfortable environment. We build this hidden strength into our air conditioners, and test them repeatedly from this viewpoint.

Silence. That Does Not Disturb You.



**Noise Test**

The operating noise of the indoor and outdoor units is measured in an echo-free chamber. The noise test verifies that the operating noise is low enough so that the product operation will not disturb daily activities including conversations and sleep.



**Amenity Test**

An actual air conditioner is operated in a test room that simulates an ordinary living room. Conditions such as the amount of sunlight entering the room from outside are changed while measuring a variety of parameters, such as cooling speed, cooling efficiency, and temperature and humidity differences throughout the room. This makes it possible to confirm whether the air conditioner is operating at its designed performance level under ordinary conditions.



**EMC (Electromagnetic Compatibility) Test**

This test determines whether electromagnetic waves emitted during operation are sufficiently low to prevent adverse effects, i.e., electrical noise, on signals such as TV and radio broadcasts.



**Remote Control Drop Test**

Because the remote control is the main interface between people and the air conditioner, it is naturally subjected to frequent impacts - such as drops and bumps - when it is passed from person to person during normal operation. Panasonic drops the remote control from a height of 1.5 metres at various angles to ensure that no problems in basic performance will result from accidental dropping.



Sunshine simulation.

Quality. Is at the Core of All Our Manufacturing.



**World Standard Quality**

Over the years, Panasonic air conditioners have continued to offer the highest possible quality with the lowest environmental impact worldwide. Naturally, the fundamental production principles that are common to all Panasonic products apply to air conditioners as well. The fact that these principles actively support every product, rather than simply serving as slogans, is the result of the endless repetition of challenges and trial-and-error efforts that are conducted at our production bases all over the world.



**Reliable Parts with Major Standards Approval**

Panasonic air conditioners comply with all of the major standards that maintain high reliability in the countries and regions where they are marketed. To ensure this, we conduct a variety of tests to examine the quality of materials used in parts.



The strength of the resin material used in the propeller fan is confirmed by the tension test.



**RoHS/REACH Compliant Parts**

All parts and materials comply with RoHS/REACH, Europe's world-leading environmental regulations. Stringent inspections of more than 100 materials are conducted to ensure that no hazardous substances are included during parts development.



**Sophisticated Production Process**

The air conditioner production line uses advanced, state-of-the-art factory automation technologies to produce products with higher reliability. Products are efficiently manufactured with high and uniform quality.



**Eco Activities**

Panasonic has set up eco ideas factories around the globe. While developing and manufacturing energy-saving products based on original environmental technologies, these factories reduce CO2 emissions from manufacturing processes and conduct regional-based environmental communication activities to contribute to both the global environment and the local communities that they serve.



## Panasonic Europe announces Sustainability Declaration

Panasonic establishes new targets for the business' environmental performance and CSR initiatives

### Best Global Green Brand 2013

We were recently awarded Interbrand's 4th Best Global Green Brand 2013 – the highest of any consumer electronics brands. This is the result of our commitment to energy efficient products, reduction in CO<sub>2</sub> emissions, our kids school 'eco learning' programme and much more.

### Sustainability Declaration. Berlin, Germany, 4th September 2013

Panasonic Europe announces today its new Sustainability Declaration for Europe and CIS, extending its current initiatives to ensure all business activities lead to a more sustainable society.

The Sustainability Declaration unites Panasonic's new brand direction towards 'A Better Life, A Better World' with a series of environmental and CSR initiatives contributing to the progress and development of society. Recognising the impact on the environment and society through its products and practices, Panasonic aims to deliver on specified targets by March 2016. The European Sustainability Declaration is in accordance with Panasonic's Global Sustainability Policy, which has been rolled out globally in recent weeks.

We aim to realise a lifestyle with virtually zero CO<sub>2</sub> emissions throughout the entire home

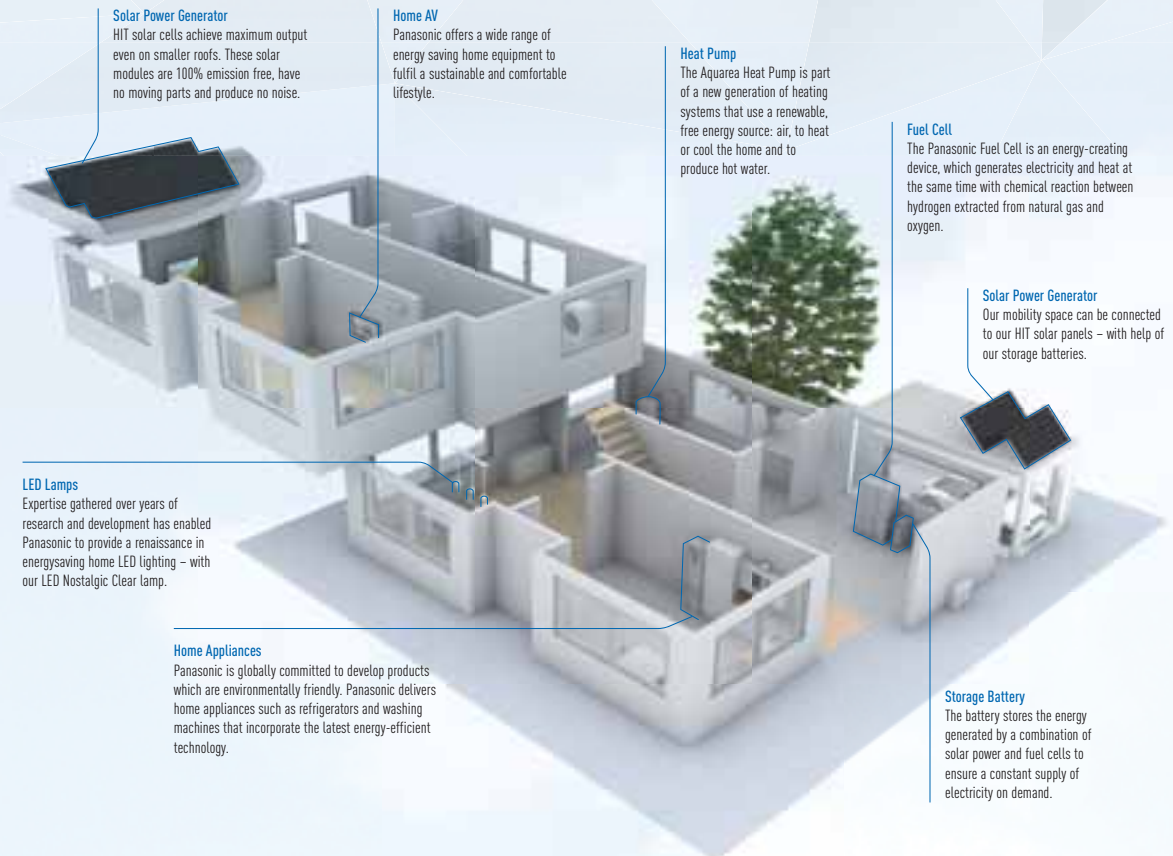

## Exemplary sustainable projects



### Fujisawa Sustainable Smart Town

Homes will employ the full range of Panasonic's most advanced systems for energy production, storage and management.

In this project, a new concept and process will be adopted to build the town by designing spaces with a primary focus on services based on people's lifestyles and creating an optimal smart infrastructure. In Fujisawa SST, Panasonic will offer its unique solutions from an Eco & Smart perspective. With bringing energy to life for residents as the town concept, we will provide services that enhance people's lives with photovoltaic power, security, mobility, community, and healthcare.

The unparalleled town building, where as many as 1,000 families will live, will serve as a new business model both within Japan and overseas.



### Panasonic joins Smart Electric Lyon consortium

#### What is Smart Electric Lyon?

Smart Electric Lyon is a project that looks at electricity consumption as a key part of the building energy solutions of tomorrow. The project aims to develop a wide range of innovative facilities and services through real-life experiments to test energy saving technologies and to measure how consumers can control energy consumption.

This experiment, unprecedented in scale in Europe, will be conducted for four years in more than 25,000 homes, businesses and communities of Grand Lyon. It is intended to test innovative solutions that will consume less and better.

Panasonic will provide the project with a variety of its energy efficient heating and cooling products, including the Aquarea Air Source Heat Pump – a super-efficient system for providing heating and / or cooling facilities, as well as the production of domestic hot water. These heat pumps are especially equipped with connectivity solutions from Panasonic to ensure the systems are easy to use, and collect the vital, accurate data. The company will also integrate other home equipment solutions such as LED white lighting products to optimize the overall energy management of the project's properties. This project is particularly apt for Panasonic, as heating and hot water occupy a prominent place in household energy consumption. Panasonic plans to make its European and French resources available for Smart Electric Lyon. The company has involved for the project a dedicated and experienced R&D team from Panasonic's European technical centre in Frankfurt.



The connected home of the future







## PRO Club: the professional website of Panasonic

**Panasonic has an impressive range of support services for designers, specifiers, engineers and distributors working in the heating and cooling markets.**

Panasonic announces a new initiative for all professionals involved in the heating and cooling business - the Panasonic PRO Club ([www.panasonicproclub.com](http://www.panasonicproclub.com)). Panasonic PRO Club is the online tool which makes your life easier! You just have to register and a lot of functionalities are freely available to you, where ever you are, from your computer or smart phone!

- **Print catalogues with your logo and your address**
- **Download the latest VRF designer with PACi units and Autocad reader**
- **Get Documents of conformity and all other documents you may need**
- **Download all the service manuals, end user manuals and installation manuals**
- **Know what to do with error codes**
- **Be the first to learn about latest news**
- **Register for in-house and online training**



[www.panasonicproclub.com](http://www.panasonicproclub.com)

or connect simply with your smartphone to the proclub using this QR:

### Highlighted Features

- Extensive library of resources
- Tools & Apps for end users. Check availability in your country:
  - My Home: sizing wizard for domestic and A2W range
  - My Project: Contact form to Panasonic team
  - iFinder: Lists of installers displayed by postcode
- Special offers & promotions
- Training PRO Academy
- Catalogues (Commercial documentation)
- Marketing (Images in high resolution, advertisements, deco guidelines)
- Tools (Professional software, sizing tools...)

### NEW Highlighted Features

- NEW! Installers customize leaflets in PDF format with their logo & contact details
- NEW! Energy label generator. Download energy labels of any device in PDF format
- NEW! Heating demand calculator
- NEW! Noise calculator for outdoor unit
- NEW! Aquarea Radiator calculator
- NEW! Error Code Search by error code or unit ref. Compatible with smartphone and tablet computer
- NEW! Revit / CAD Images / Spec texts
- NEW! Access to Pananet, online library of technical documentation
- NEW! Download Documents of Conformity and other Certifications
- NEW! Commissioning online





NEW! Easy download Panasonic service documentation and brochures



Panasonic PRO Club is fully compatible with tablet computer and smartphone



NEW! Customize leaflets with your logo & contact details. Save and print the PDF



NEW! Energy label generator. Download Energy labels of any device in PDF format



NEW! Error Code on your smartphone and your PC: Search by error code or model reference. Online version + downloadable version for offline use

**The Panasonic PRO Academy opens its doors**

Panasonic takes its responsibility to its distributors, specifiers and installers seriously and has developed a comprehensive Training Programme. The Panasonic Pro-Academy encompasses the traditional hands-on approach, as well as embracing today's technology to offer an eLearning facility available 24 hours, 7 days a week!

New training courses cover three levels. Design, installation, and commissioning & trouble-shooting. Training courses include:

- Domestic applications Air to Air
- Aquarea air source heat pumps
- VRF ECOi

The courses are offered on site at Panasonic's premises across Europe as well as via the Panasonic ProClub eLearning site. The Training Centres display Panasonic's latest product range and give delegates an opportunity to get hands-on experience with the latest controllers, indoor and outdoor units from the VRF ECOi, Etherea, GHP and Aquarea ranges.

**High  
savings****ECO G****ECO G**

## Panasonic introducing the gas driven VRF

Panasonic's GHP range is extensive and covers the 2-Pipe and 3-Pipe system. Our GHP VRF range of commercial systems is leading the industry in the development of efficient and flexible systems, and is the natural choice for commercial projects, especially those where power restrictions apply. As you would expect, all our gas-driven VRF systems have the highest reliability rates in the industry and a leading customer service programme. The torque and rpm control functions of the GHP's motor are comparable with an inverter-type electric air conditioner. Thus, the GHP ensures individual, and efficient control and performance - just as you expect from an electric inverter controlled air conditioner.

### **Easy to position**

- Up to 71 kW of cooling from a current consumption of 0,1 kW/h
- Single Phase power supply across the range
- The option of natural gas or LPG as its main power source
- Embedded Water Heat Exchanger to connect to domestic hot water systems 16–25 HP (2-Pipe units only)
- Option of DX or chilled water for indoor heat exchange
- Reduced CO<sub>2</sub> emissions

## ECO G and ECO G Multi, S Series

The advanced Gas Driven VRF system offers increased efficiency and performance across the range. Now more powerful than ever before, it can connect up to 48 indoor units. Improvements include increased part load performance, reduced gas consumption with a Miller-cycle engine and reduced electrical consumption by using DC fan motors.

### ECO G High Power

1% this is what the new ECO G High Power is consuming versus your Electrical VRF. Your savings start now! Ideal for locations with low electricity grid, for chiller, ventilation and air conditioning application.



### ECO G and ECO G Multi

The S Series 2-Pipe not only offers improved performance but also increased flexibility.



### ECO G 3 Way

3 Way heat recovery system with simultaneous heating & cooling.



## ECO G and ECO G Multi benefits

### High-efficiency operation

All models are equipped with a high-performance air exchanger and a newly developed refrigerant heat exchanger for high efficiency operation, making them one of the most energy efficient solutions on the market.

### Lowest nitrogen oxide emissions

The GHP VRF systems have the lowest nitrogen oxide emissions. In a pioneering development, the Panasonic GHP features a brand new lean-burn combustion system that utilises air fuel ratio feedback control to reduce NOx emissions to an all time low.

### High performance

With its advanced heat exchanger design, this new GHP system offers improved efficiency and reduced running costs, which, coupled with improved engine management systems, have greatly improved the system COP rating.

### Excellent economy

The Panasonic GHP provides quick and powerful cooling/heating and increases delivery of heat into the space by the efficient recovery of heat from the engine cooling water, which is injected into the refrigerant circuit by a highly efficient plate heat exchanger. In addition, the use of engine waste heat ensures that our gas heat pump air conditioner requires no defrost cycle, therefore providing continuous 100% heating performance in severe weather conditions with an outside air temperature as low as -20°C. During cooling mode the rejected heat from the engine is available for use with in a DHW system and can supply up to 30 kW of hot water at 75°C. The DHW is also available in heating when the outside air temp is above 7°C.

### Water chiller option

Our GHP system is also available with a water chiller option, which can be combined with individual outdoor units or as part of a DX chilled water mix of indoor units. The system can be operated via a BMS system or a Panasonic supplied control panel, with chilled water set points from -15°C – +15°C and heating set points 35°C – +55°C.

### No defrost requirements



Below 4°C ambient in heating mode, the outdoor fans switch OFF, saving further running costs and CO<sub>2</sub> emissions.

## ECO G with Water Heat Exchanger for chilled and hot water production

For hydronic applications.



## ECO G Outdoor Units Range

	16 HP	20 HP	25 HP	30 HP	32 HP	36 HP	40 HP	45 HP	50 HP
Capacity (Cooling / Heating)	45,00 / 50,00 kW	56,00 / 63,00 kW	71,00 / 80,00 kW	85,00 / 95,00 kW	90,00 / 100,00 kW	101,00 / 113,00 kW	112,00 / 126,00 kW	127,00 / 143,00 kW	142,00 / 160,00 kW
									
ECO G High Power	U-16GEP2E5	U-20GEP2E5	U-25GEP2E5						
ECO G and ECO G Multi	U-16GE2E5	U-20GE2E5	U-25GE2E5	U-30GE2E5	U-16GE2E5 U-16GE2E5	U-16GE2E5 U-20GE2E5	U-20GE2E5 U-20GE2E5	U-20GE2E5 U-25GE2E5	U-25GE2E5 U-25GE2E5
ECO G 3 Way	U-16GF2E5	U-20GF2E5	U-25GF2E5						

### Comparison of heating capacity

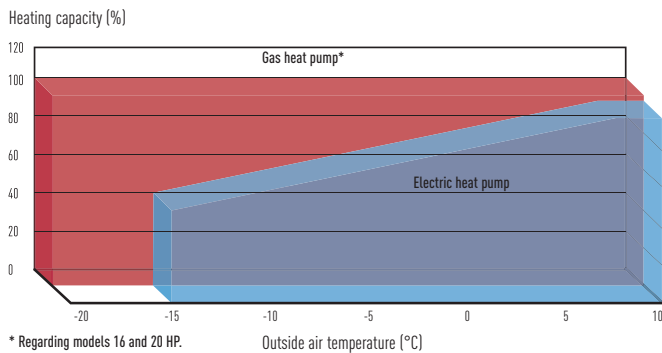

### Comparison of the start times for heating operation

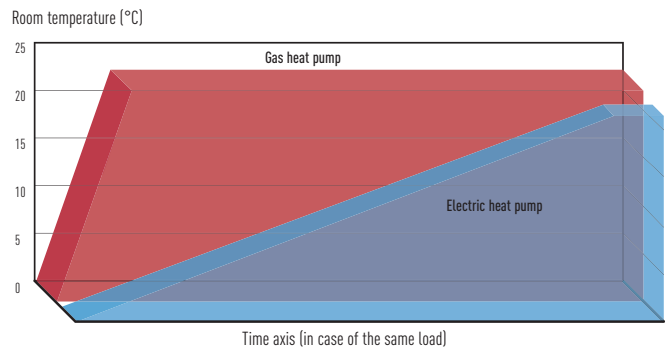

### The Gas Heat Pump (GHP)

Panasonic Gas Heat Pump is the natural choice for commercial projects, especially for those projects where power restrictions apply. As you would expect, all of our Gas Driven VRF systems are designed to give the highest reliability rates. The GHP engine or (internal combustion engine) varies the engine speed to match the building load functions that are comparable with an inverter type electric air conditioner.

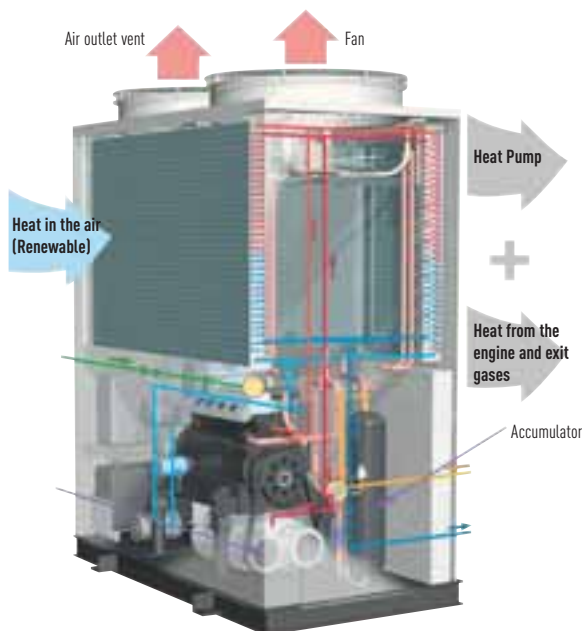

### Power supply problems?

If you are short of electrical power, our gas heat pump could be the perfect solution:

- Runs on natural gas or LPG and just needs Single Phase supply
- Enables the building's electrical power supply to be used for other critical electrical demands
- Reduces capital cost to upgrade power substations to run heating and cooling systems
- Reduces power loadings within a building especially during peak periods
- Electricity supply freed up for other uses such as IT servers, commercial refrigeration, manufacturing, lighting etc.

### GHP Outdoor Heat Exchanger

- Integrated DX and hot water coil
- No defrost required
- Faster reaction to demand for heating

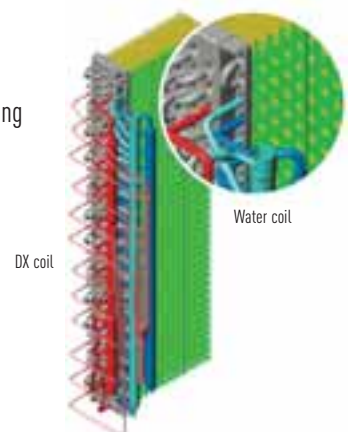





## ECO G High Power

### 2-Pipe Heat Pump System with Electrical Power Generator

#### Production of electricity

Generates up to 2 kW depending on air conditioning load.

#### Panasonic innovates again introducing a new GHP producing his own electricity.

Equipped with a small, high-performance generator. Compressor and generator are driven by gas engine. The generated electricity is used for the fan motor and cooling water pump of its own unit. The generating efficiency is more than 40%.

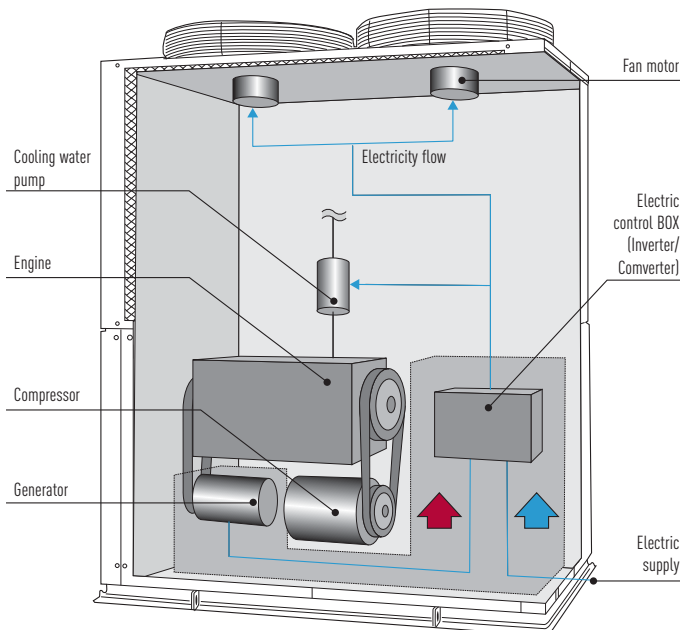

### ECO G High Power

GHP with electrical generator. Only consumes 1% of the electricity required by standard VRF systems!

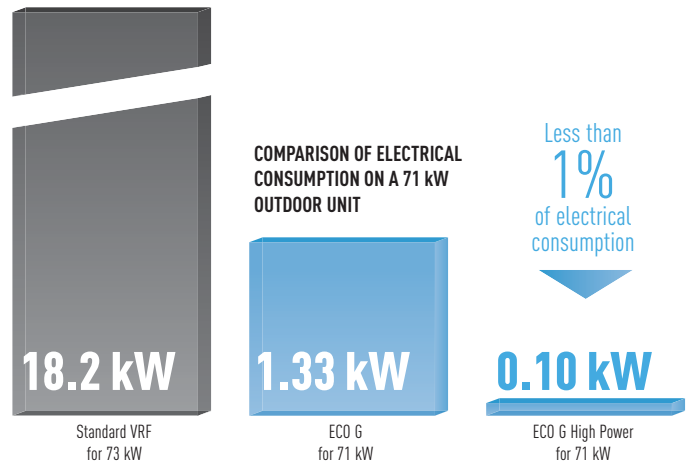

# ECO G High Power, ECO G and ECO G Multi

## 2-Pipe Heat Pump System

### Easy to add additional units in the future

Load can easily be increased in the future by the addition of indoor and outdoor units without having to plumb pipe shafts.

\* When specifying refrigerant pipe work, please choose the size according to the horsepower after the increase of units.

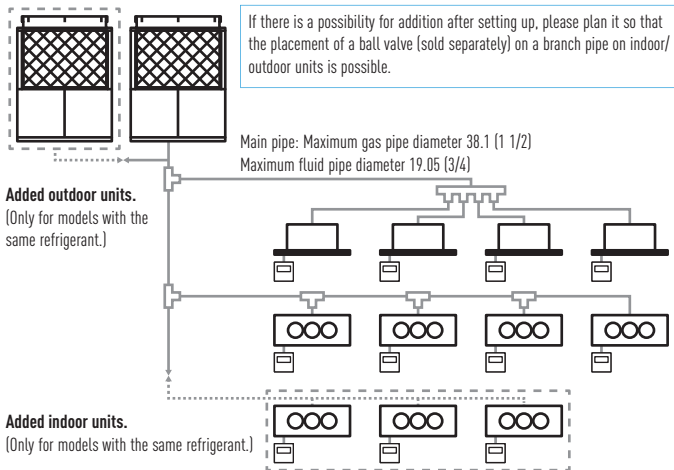

Maximum possible number of outdoor units to be combined	2 units
Maximum horsepower of combined outdoor units	50 HP
Maximum possible number of indoor units to be connected	48 units <sup>1</sup>
Indoor/outdoor units capacity ratio	50%~130% <sup>2</sup>

1) When 2 outdoor units are connected. 2) Capacity of indoor units connection is: Minimum; 50% of the capacity of the smallest outdoor unit within the system, Maximum; 130%: total capacity of the system outdoor units. Indoor units are same as multi series for buildings.

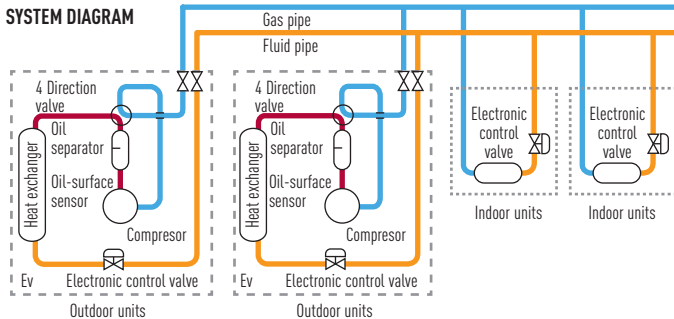

### Saving Energy

- Energy savings achieved by the appropriate capacity.
- Equational program function.

Energy savings are achieved by the appropriate load divider function, which enables efficient operation by concentrating the cooling/heating capacity to one outdoor unit and stopping the other. Compared to conventional machines with a similar COP, this function allows energy savings and thus reduces the running costs, especially in part-load seasons like spring and autumn.

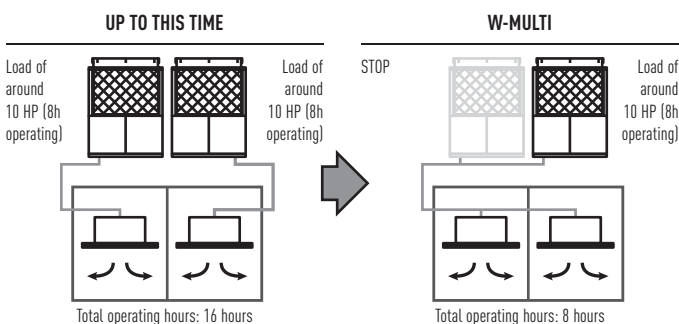

### Non-stop operation, even during maintenance

- System will not stop even during maintenance, due to Manual Backup Operating Function.
  - Maintenance is possible during weekdays because it can continue operating during maintenance.
  - Automatic Backup Operating Function enables continuous operation.
- If one outdoor unit stops the backup function will automatically start on the remaining unit and continue operating. During service intervals, the system being serviced can be isolated by a closing valve in the outdoor unit, enabling continuous operation with the still operative outdoor unit.

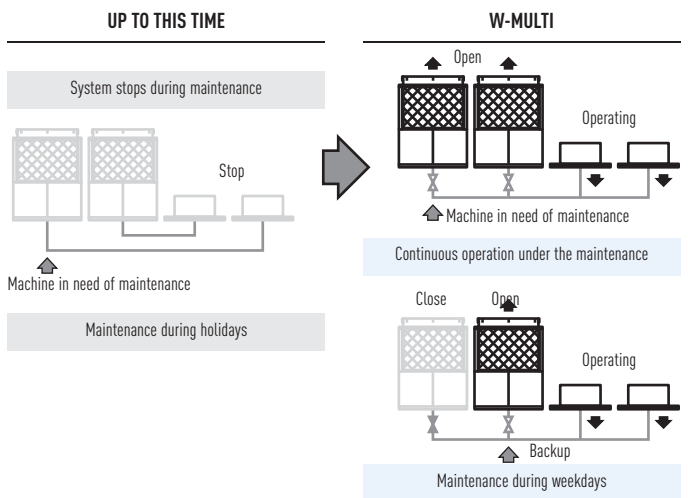

### Long lifetime

- Renewal period prolonged due to rotation function.
- Rotation function, which is run from outdoor units with low operating time, will average the operating hours of each outdoor unit. This extends the periods between maintenance or replacement.

#### EXAMPLE OF THE ROTATION FUNCTION

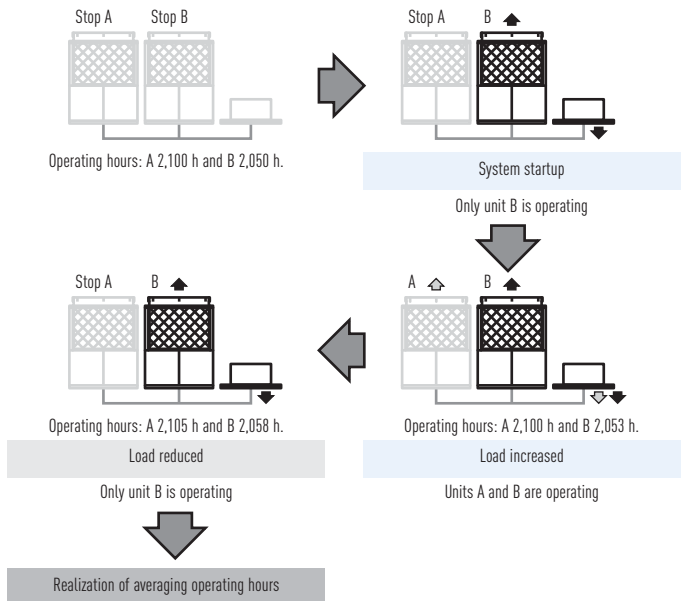

## ECO G 3 Way

### Ease of construction

- By using common header pipe work the installation cost and time is significantly reduced.
- By combining all pipes, which were needed for each indoor unit, into a common pipe in each system, the number of pipes are reduced by half\* which leads to ease of construction. Furthermore, space of pipes within pipe shafts can be reduced by 2/3.\*
- Combining all pipes, which were needed for each outdoor unit, into a pipe in each system. (Number of pipes is reduced by half).

\*System with approximately 40HP (20HP x 2 units)

### EXAMPLE OF A SYSTEM WITH APPROXIMATELY 40 HP

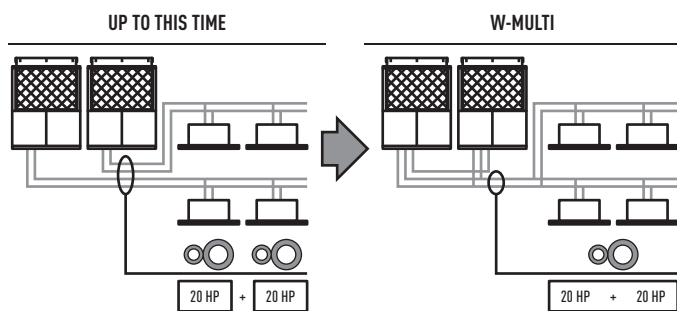

### Hot Water Supply Function

- System Advantage.
- The engine waste heat, which is normally exhausted into the atmosphere, is recovered via the heat exchanger and effectively used to heat water, so the GHP Chiller acts as embedded sub system that alleviates the load on the client's main hot water system, and therefore offers 'free' hot water.

Capacity at cooling standard point		Outlet temperature 75°C	
Outdoor unit	U-16GE2E5	kW	15,00
	U-20GE2E5		20,00
	U-25GE2E5		30,00
	U-30GE2E5		30,00
Hot water piping allowable pressure		MPa	0,7
Hot water circulation rate		m³/h	3,9
Hot water tube size		Rp	3/4

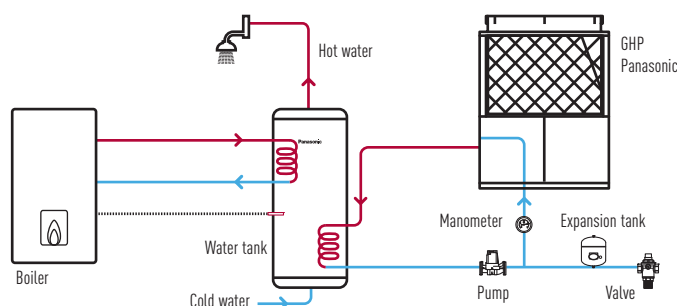
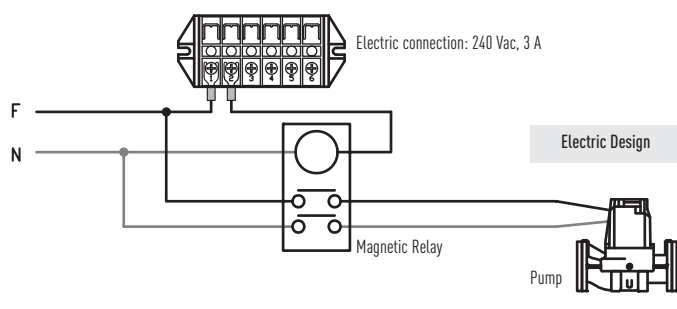

- All the items illustrated in this drawing (except the outdoor unit) are not supplied by Panasonic.  
 - During start up, set temperature value of the water in the outdoor unit's parameter.

### Excellent performance

Panasonic 3 WAY Multi system is capable of simultaneous heating/cooling and individual operation of each indoor unit by only one outdoor unit. As a result, efficient individual air conditioning is possible in buildings having diverse room temperatures.

### System example

Improved maintenance intervals. The unit only needs to be serviced every 10,000 hours. This is the best in the industry.

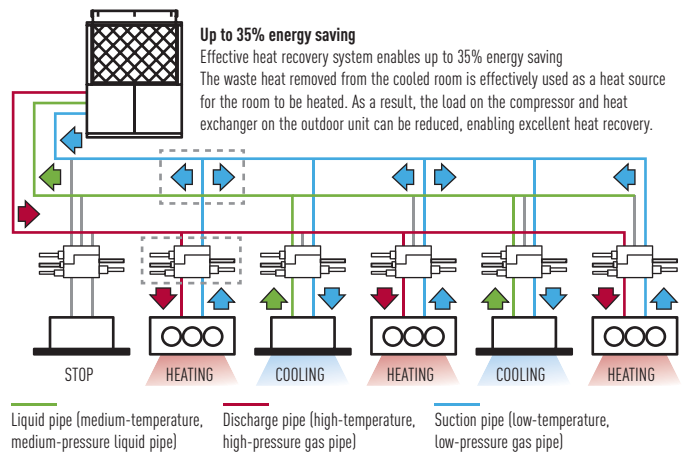

### Solenoid valve kit

To be fitted on all 'zones' to allow simultaneous heating and cooling. Up to 36 indoor units are capable of simultaneous heating/cooling operation. Oil-recovery operation to gives more stable comfort air-conditioning control.

#### 3-PIPE CONTROL SOLENOID VALVE KIT

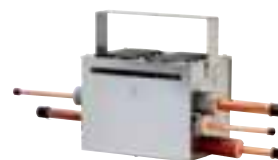

#### CZ-P56HR3

Up to 5.6 kW  
 CZ-P160HR3  
 From 5.7 to 16 kW

#### KIT-P56HR3

(CZ-P56HR3+CZ-CAPE2)  
 KIT-P160HR3  
 (CZ-P160HR3+CZ-CAPE2)

#### 3-PIPE CONTROL PCB



#### 3-Pipe control PCB CZ-CAPE2\*

Must be added to the CZ-P56HR3 OR CZ-P160HR3.  
 \* For wall mounted.

### VALVE DIMENSIONS

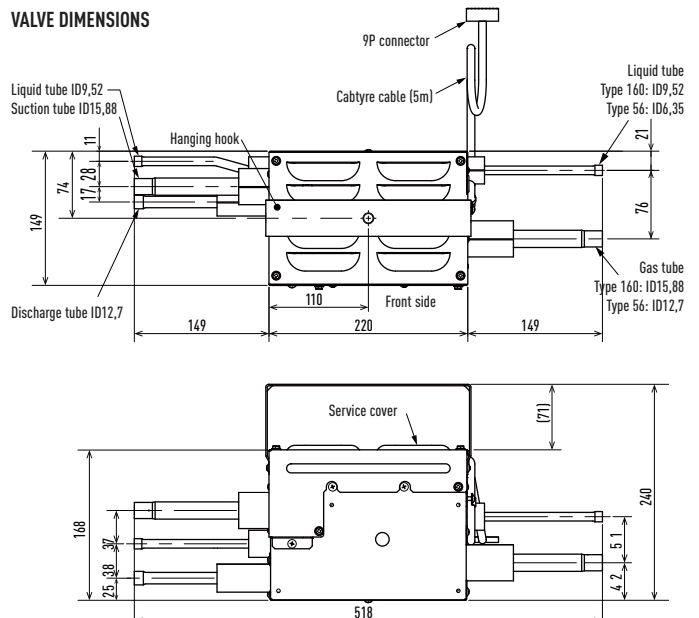





## ECO G Water Heat Exchanger for hydronic applications

**Connection to chilled water coils in air handling equipment.**

### **Air Handling application**

When a top London restaurant opened, it needed large volumes of fresh air to ensure the optimum dining environment. GHP units connected to the cooling coils within the air handling equipment ensured the air was introduced in the right condition in both summer and winter.





**Chiller replacement. Chilled water supply to fan coils.**

**Chiller replacement**

When some old chillers needed replacing at the end of their operational lifetime, GHPs with Water Heat Exchangers enabled the project to be carried out in stages whilst still utilising the existing water pipe work and fan coils. This enabled the project to be delivered on time, to a restricted budget and avoided all issues regarding refrigerant in confined spaces.



**Connection to 'close control' computer equipment.**

**Computer room applications**

When all available electrical power needed to be utilised for the IT equipment for a leading international bank, the cooling load of over 450 kW had to be powered by gas. The outdoor units were connected via Water Heat Exchangers to cooling coils inside the 'close control' units thereby maintaining a conditioned environment for temperature and humidity. By utilising the hot water function over 100 kW of hot water are supplied to the building and therefore the additional benefit of considerable CO<sub>2</sub> savings is ensured.

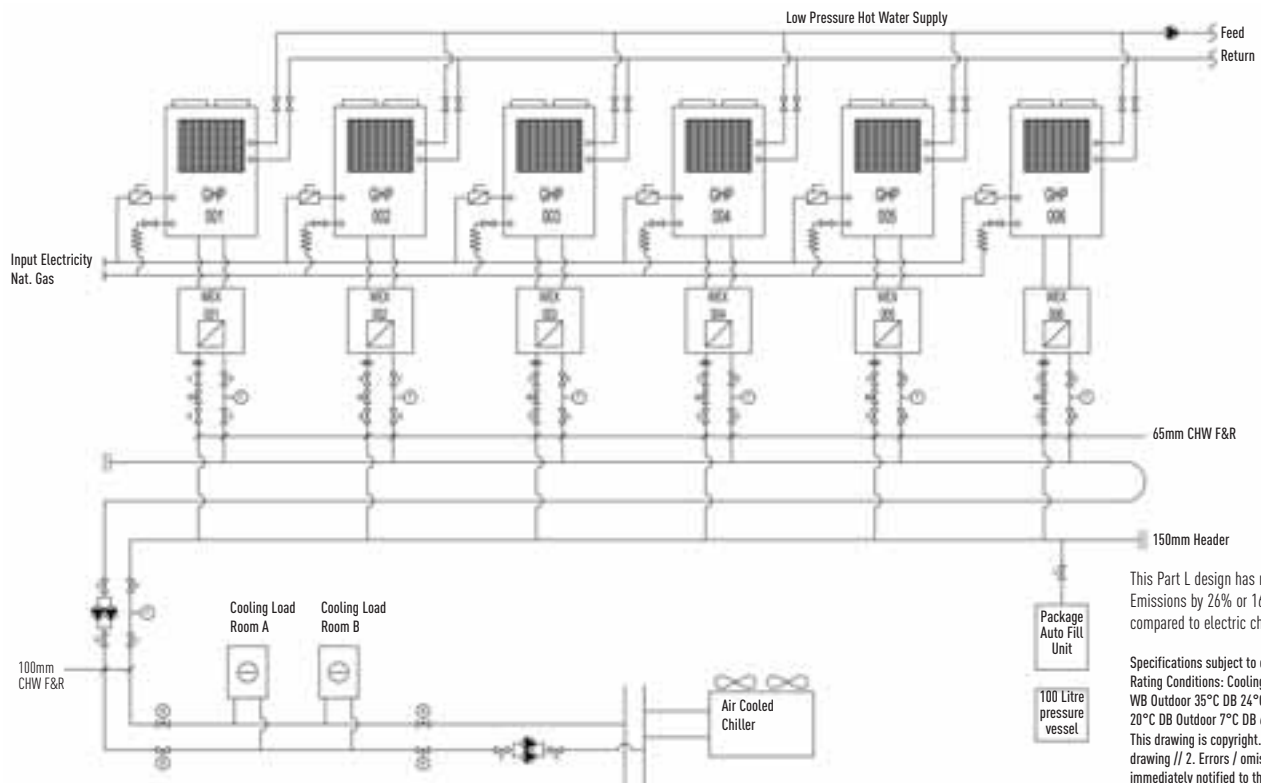

This Part L design has reduced CO<sub>2</sub> Emissions by 26% or 166 tonnes per annum compared to electric chillers.

Specifications subject to change without notice.  
 Rating Conditions: Cooling Indoor 27°C DB 19°C WB Outdoor 35°C DB 24°C WB Heating Indoor 20°C DB Outdoor 7°C DB 6°C WB.  
 This drawing is copyright. // 1. Do not scale this drawing // 2. Errors / omissions to be immediately notified to the Engineer. // 3. All dimensions to be checked on site.

## ECO G HIGH POWER

## The 2-Pipe Gas Driven VRF with an electrical power generator

ECO G High Power is a revolution in air conditioning design. Fitted with a permanent magnet, non-bearing type generator, it is the first VRF system that can supply heating, cooling, hot water and now also supply electrical power. Each ECO G High Power unit has a 2.0 kW generator, drastically reducing the outdoor unit's electricity consumption.



HP			16 HP	20 HP	25 HP
<b>Model</b>			<b>U-16GEP2E5</b>	<b>U-20GEP2E5</b>	<b>U-25GEP2E5</b>
Cooling capacity		kW	45,00	56,00	71,00
Hot water (cooling mode)		kW	15,0	20,0	30,0
Power Input		kW	0,1 (220-230) 0,36 (240)	0,1 (220-230) 0,36 (240)	0,1 (220-230) 0,36 (240)
EER	Nominal	W/W			
<b>Max COP (inc hot water)</b>					
Gas consumption		kW	31,3	41,4	63,5
Heating capacity	STD / Low temp <sup>1</sup>	kW	50,0 / 53,0	63,0 / 67,0	80,0 / 78,0
Power Input		kW	0,1 (220-230) 0,36 (240)	0,1 (220-230) 0,36 (240)	0,1 (220-230) 0,36 (240)
COP	Nominal	W/W			
Gas consumption	STD	kW	33,8	43,9	55,1
	Low temperature <sup>1</sup>	kW			
COP	Average				
Starter amperes		A	30	30	30
Sound pressure level		dB(A)	57	58	62
Dimensions	H x W x D	mm	2.273 x 1.650 x 1.000 (+80)	2.273 x 1.650 x 1.000 (+80)	2.273 x 1.650 x 1.000 (+80)
Net weight		kg	770	795	825
Pipe Connections	Gas	Inch (mm)	1 1/8 (28,58)	1 1/8 (28,58)	1 1/8 (28,58)
	Liquid	Inch (mm)	1/2 (12,70)	5/8 (15,88)	5/8 (15,88)
	Fuel gas		R3/4 (bolt thread)	R3/4 (bolt thread)	R3/4 (bolt thread)
	Exhaust drain port	mm	25	25	25
Indoor/outdoor capacity ratio			50-200% <sup>2</sup>	50-200% <sup>2</sup>	50-200% <sup>2</sup>
Number of connections indoor <sup>2</sup>			24	24	24

Service kits model	Kit CZ-PSK560S
Outdoor unit reference	U-16GEP2E5 / U-20GEP2E5 / U-25GEP2E5
Material included	
Oil Filter	1
Air Cleaner Element	1
Plug	4
V BELT (for compressor)	1
V Belt (for generator)	1
Oil Strainer	1
Drain Filter Packing	1

Rating Conditions: Cooling Indoor 27°C DB / 19°C WB. Cooling Outdoor 35°C DB. Heating (standard) Indoor 20°C DB. Heating (standard) Outdoor 7°C DB / 6°C WB. Heating (low temp.) Indoor 20°C DB / 15°C WB or less. Heating (low temp.) Outdoor 2°C DB / 1°C WB. DB: Dry Bulb; WB: Wet Bulb

1) Low temp condition: outdoor temperature 2°C.

2) Indoor unit can be connected to up to 16 kW model (model size 160)

Specifications subject to change without notice.

Cooling and heating capacities in the tables are determined under the test conditions of JIS B 8627.

Effective heating requires that the outdoor air intake temperature be at least -20°C DB or -21°C WB.

- Gas consumption is the total (high) calorific value standard. - Outdoor unit operating sound is measured 1 meter from the front and 1.5 meters above the floor (in an anechoic environment). Actual installations may have larger values due to ambient noise and reflections. - Specifications are subject to change without notice. - Hot water heating capacity is applicable during cooling operation. - The maximum water temperature that can be obtained is 75°C. Water heating performance and temperature vary with the air conditioning load. Because the hot water heating system uses waste heat from the engine, which runs the air conditioning, its ability to heat water is not guaranteed.



**U-16GEP2E5 // U-20GEP2E5 // U-25GEP2E5**

**Technical focus**

- 2-Pipe air conditioning system providing cooling or heating
- Up to 2 kW electricity generated (used on the outdoor unit)
- Very efficient generator
- Can connect to up to 24 indoor units
- IU/OU capacity ratio 50–200%
- 15 to 30 kW hot water generation capacity
- Free Hot water provided when in cooling throughout temperature range and in heating when the ambient is above 7°C\*
- 200 m maximum allowable piping length (L1)

\* Referring to outside temperature.

**Generates electricity during heating or cooling operation**

Generates electricity and air conditioning (heating or cooling) at the same time by using remaining engine power. ECO G High Power can generate 2.0 kW electricity at a generation efficiency of more than 40%.

**SERVICE CLEARANCES FOR INSTALLATION**

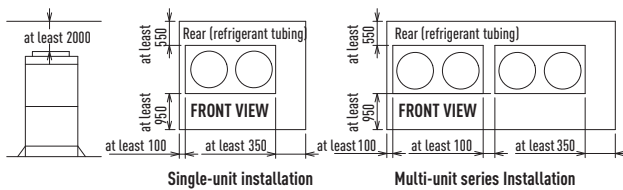

kW	45.0	56.0-71.0
1 Suction refrigerant pipe	Ø 28.58	
2 Liquid refrigerant pipe	Ø 12.7	Ø 15.88
3 Exhaust gas drain port	HOSE OD Ø 25 (accessory)	
4 Electrical power supply port	Ø 28	
5 Inter-unit cable port	Ø 28	
6 Fuel gas port	R3/4	
7 Condensation drain opening	Ø 20	
8 Rain and condensation outlet		
9 Engine exhaust outlet		
10 Suspension holes 4-Ø 20x30		
11 Anchor holes 4-Ø 22x30		
12 Segmented display		
13 Coolant intake (top)		
14 Vent		
15 Hot water inlet	Rp 3/4	
16 Hot water outlet	Rp 3/4	

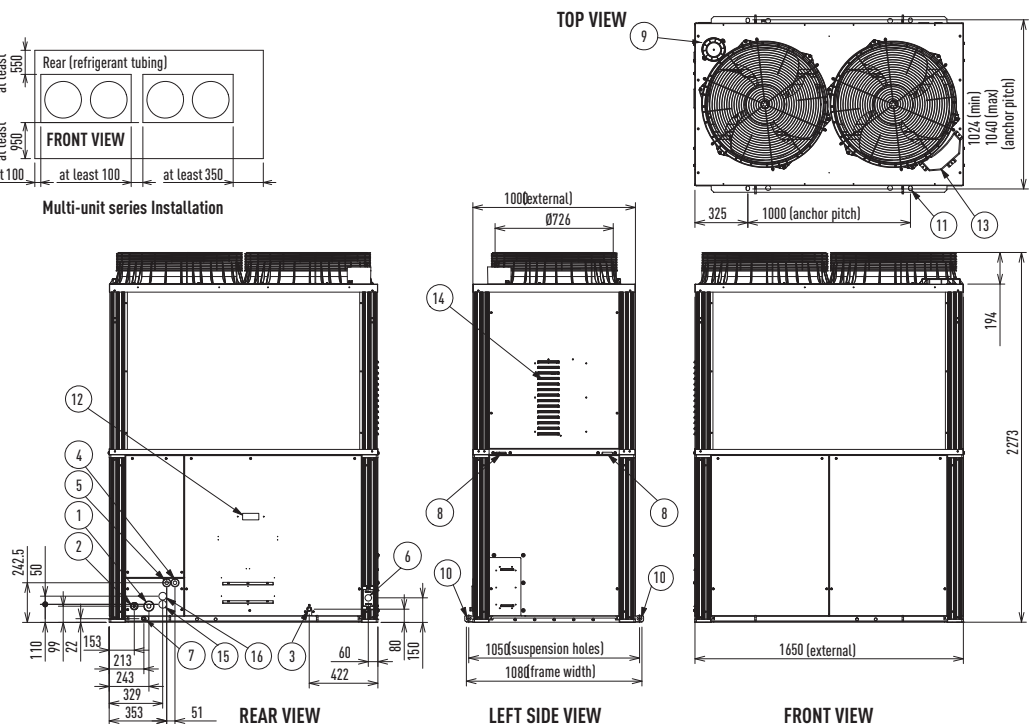



ECO G AND ECO G MULTI

2-Pipe Heat Pump System

ECO G and ECO G Multi 2-Pipe for Heat Pump Applications.

The S Series 2-Pipe not only offers improved performance but also increased flexibility. Now available as multi-systems, many combinations are possible, from 16 HP to 50 HP, allowing for more power and enabling accurate matching of a system building load. Additional new features include part load engine management and compressor run hour equalisation.



HP		16 HP	20 HP	25 HP	30 HP	32 HP	36 HP*	40 HP*	45 HP*	50 HP
Model		U-16GE2E5	U-20GE2E5	U-25GE2E5	U-30GE2E5	U-16GE2E5 U-16GE2E5	U-16GE2E5 U-20GE2E5	U-20GE2E5 U-20GE2E5	U-20GE2E5 U-25GE2E5	U-25GE2E5 U-25GE2E5
Cooling capacity	kW	45,00	56,00	71,00	85,00	90,00	101,00	112,00	127,00	142,00
Hot water (cooling mode)	kW	15,00	20,00	30,00	30,00	30,00	35,00	40,00	50,00	60,00
Power Input	kW	0,71	1,02	1,33	1,70	1,42	1,73	2,04	2,35	2,66
EER (Calorific Value) <sup>1</sup>	High / Low	W/W	1,48 / 1,64	1,40 / 1,55	1,15 / 1,28	1,22 / 1,35	1,48 / 1,64	1,43 / 1,59	1,40 / 1,55	1,25 / 1,39
Max COP (inc hot water)			1,97	1,89	1,64	1,65	1,97	1,93	1,89	1,74
Gas consumption	kW	29,70	39,10	60,40	67,9	59,40	68,80	78,20	99,50	120,80
Heating capacity	STD / Low temperature <sup>2</sup>	kW	50,00 / 53,00	63,00 / 67,00	80,00 / 78,00	95,00 / 90,00	100,00 / 106,00	113,00 / 120,00	126,00 / 134,00	143,00 / 145,00
Power Input	kW	0,60	0,64	0,83	1,45	1,20	1,24	1,28	1,47	1,66
COP (Calorific Value) <sup>1</sup>	High / Low	W/W	1,51 / 1,68	1,46 / 1,62	1,48 / 1,64	1,37 / 1,52	1,51 / 1,68	1,48 / 1,64	1,46 / 1,62	1,47 / 1,63
Gas consumption	STD	kW	32,50	42,50	53,20	68,10	65,00	75,00	85,00	95,70
	Low temperature <sup>2</sup>	kW	41,50	56,40	62,30	78,00	83,00	97,90	112,80	124,60
COP	Average		1,50	1,43	1,32	1,29	1,50	1,46	1,43	1,36
Starter amperes	A	30	30	30	30	30	30	30	30	30
Sound pressure level	dB(A)	57	58	62	63	60	61	61	63	65
Dimensions	Height	mm	2.273	2.273	2.273	2.273	2.273	2.273	2.273	2.273
	Width	mm	1.650	1.650	1.650	2.026	1.650+100+1.650	1.650+100+1.650	1.650+100+1.650	1.650+100+1.650
	Depth	mm	1.000 (+80)	1.000 (+80)	1.000 (+80)	1.000 (+80)	1.000 (+80)	1.000 (+80)	1.000 (+80)	1.000 (+80)
Net weight	kg	755	780	810	840	755 + 775	755 + 780	780 + 780	780 + 810	810 + 810
Pipe Connections	Gas	Inch (mm)	1 1/8 (28,58)	1 1/8 (28,58)	1 1/8 (28,58)	1 1/4 (31,75)	1 1/4 (31,75)	1 1/2 (38,10)	1 1/2 (38,10)	1 1/2 (38,10)
	Liquid	Inch (mm)	1/2 (12,70)	5/8 (15,88)	5/8 (15,88)	3/4 (19,05)	3/4 (19,05)	3/4 (19,05)	3/4 (19,05)	3/4 (19,05)
	Fuel gas		R3/4 (bolt thread)	R3/4 (bolt thread)	R3/4 (bolt thread)	R3/4 (bolt thread)	R3/4 (bolt thread)	R3/4 (bolt thread)	R3/4 (bolt thread)	R3/4 (bolt thread)
	Exhaust drain port	mm	25 rubber hose	25 rubber hose	25 rubber hose	25 rubber hose	25 rubber hose	25 rubber hose	25 rubber hose	25 rubber hose
Indoor/outdoor capacity ratio		50-200 %	50-200 %	50-200 %	50-170 %	50-130 %	50-130 %	50-130 %	50-130 %	50-130 %
Number of connections indoor		24	24	24	32	48	48	48	48	48

GHP Service kits model names	Kit CZ-PSK560S	Kit CZ-PSK850S
Outdoor unit reference	U-16GE2E5 / U-20GE2E5 / U-25GE2E5	U-30GE2E5
Material included on the kit		
Oil Filter	1	1
Air Cleaner Element (Air Filter)	1	1
Plug	4	4
V BELT (for compressor)	1	1
V Belt (for generator)	-	-
Oil Strainer	1	1
Drain Filter Packing	1	1

Rating Conditions: Cooling Indoor 27°C DB / 19°C WB. Cooling Outdoor 35°C DB. Heating (standard) Indoor 20°C DB. Heating (standard) Outdoor 7°C DB / 6°C WB. Heating (low temp.) Indoor 20°C DB / 15°C WB or less. Heating (low temp.) Outdoor 2°C DB / 1°C WB. DB: Dry Bulb; WB: Wet Bulb

\* In these combinations, GE2E5 is able to connect to a W-multi system Specifications subject to change without notice instead of a GE2E5.

1) Referred to Natural Gas (HCV=55,489 MJ/kg; LCV=50,013 MJ/kg). 2) Low temperature condition: outdoor temperature 2°C. Specifications subject to change without notice.

Cooling and heating capacities in the tables are determined under the test conditions of JIS B 8627. Effective heating requires that the outdoor air intake temperature be at least -20°C DB or -21°C WB.

- Gas consumption is the total (high) calorific value standard. - Outdoor unit operating sound is measured 1 meter from the front and 1.5 meters above the floor (in an anechoic environment). Actual installations may have larger values due to ambient noise and reflections. - Specifications are subject to change without notice. - Hot water heating capacity is applicable during cooling operation. - The maximum water temperature that can be obtained is 75°C. Water heating performance and temperature vary with the air conditioning load. Because the hot water heating system uses waste heat from the engine, which runs the air conditioning, its ability to heat water is not guaranteed.



**U-16GE2E5 // U-20GE2E5 // U-25GE2E5 // U-30GE2E5**

**Technical focus**

- Reduced gas consumption by Miller-cycle engine
- Reduced electrical power consumption by using DC Motors
- Lightweight design reduces weight
- Capacity ratio 50-130% (single models only)
- Quiet mode offers a further 2 dB(A) reduction
- Part load efficiencies increased
- Connectivity increased - now up to 48 indoor units
- Multi-systems with combinations from 13 HP up to 50 HP
- 10,000 run hours between engine service intervals (equivalent to one maintenance every 3.2 years\*)
- 200 m maximum allowable piping length (L1)
- Extended pipe runs (total 780 m)

- Full heating capacity down to -20°C
- No defrost cycle

\* Assuming 3,120 running hours per year - 12 h x 5 days x 52 weeks

**Sample installation**



kW	45	56 - 71	85
1 Gas refrigerant pipe	Ø 28.58	Ø 31.75	Ø 31.75
2 Liquid refrigerant pipe	Ø 12.7	Ø 15.88	Ø 19.05
3 Exhaust gas drain port	HOSE OD Ø 25 (accessory)		
4 Electrical power supply port	Ø 28		
5 Inter-unit cable port	Ø 28		
6 Fuel gas port	R3/4		
7 Condensation drain opening	Ø 20		
8 Rain and condensation outlet			
9 Engine exhaust outlet			
10 Suspension holes 4-Ø 20x30			
11 Anchor holes 4-Ø 22x30			
12 Segmented display			
13 Coolant intake (top)			
14 Vent			
15 Hot water intake	Rp3/4		
16 Hot water outlet	Rp3/4		

**U-16GE2E5 // U-20GE2E5 // U-25GE2E5**

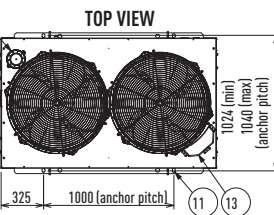

**U-30GE2E5**

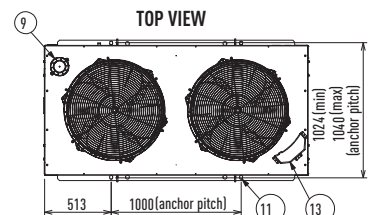

**SERVICE CLEARANCES FOR INSTALLATION**

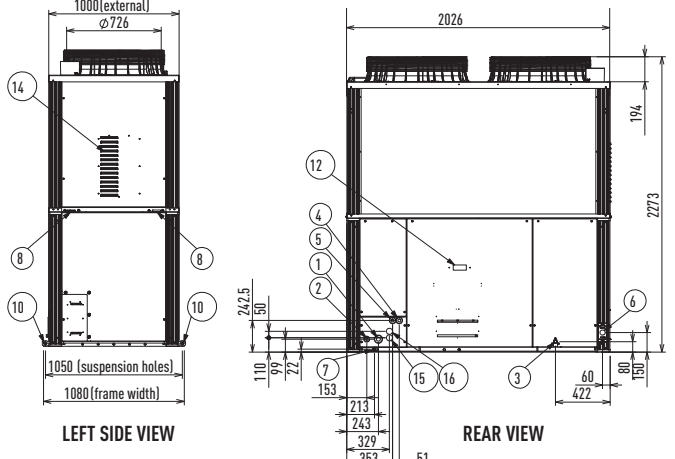
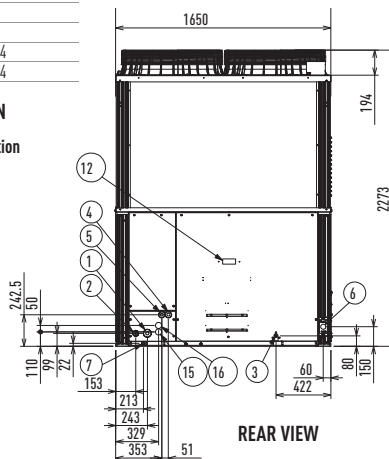
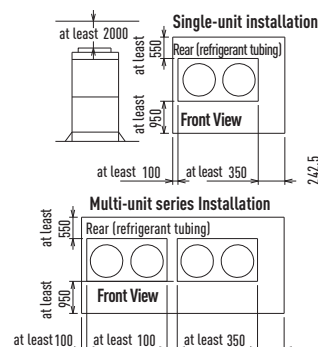

## ECO G 3 WAY

## 3 Way Heat Recovery System with Simultaneous Heating &amp; Cooling

The only 3 Way GHP system in Europe, the S Series ECO G 3 Way offers even more performance and outstanding features when you need simultaneous heating and cooling. Now with capacities available from 16 HP to 25 HP, Panasonic offers the greatest choice and flexibility to solve any power problem or site requirement.



HP			16 HP	20 HP	25 HP
Model			U-16GF2E5	U-20GF2E5	U-25GF2E5
Cooling capacity		kW	45,00	56,00	71,00
Power input cooling		kW	0,71	1,02	1,33
EER (Calorific Value) <sup>1</sup>	High / Low	W/W	1,48 / 1,64	1,40 / 1,55	1,15 / 1,28
Cooling gas consumption		kW	29,7	39,1	60,4
Heating capacity	STD	kW	50,00	63,00	80,00
	Low temperature <sup>2</sup>	kW	53,00	67,00	78,00
Power input heating		kW	0,60	0,64	0,83
COP (Calorific Value) <sup>1</sup>	High / Low	W/W	1,51 / 1,68	1,46 / 1,62	1,48 / 1,64
Gas consumption	STD	kW	32,5	42,5	53,2
	Low temperature <sup>2</sup>	kW	41,5	56,4	62,3
COP		Average	1,50	1,43	1,32
Starter amperes		A	30	30	30
Operation sound		dB(A)	57	58	62
Dimensions		H x W x D	2,273 x 1,650 x 1,000 (+80)	2,273 x 1,650 x 1,000 (+80)	2,273 x 1,650 x 1,000 (+80)
Net weight		kg	775	775	805
Pipe Connections	Gas	Inch (mm)	1 1/8 (28,58)	1 1/8 (28,58)	1 1/8 (28,58)
	Liquid	Inch (mm)	3/4 (19,05)	3/4 (19,05)	3/4 (19,05)
	Discharge	Inch (mm)	7/8 (22,22)	1 (25,40)	1 (25,40)
	Fuel gas		R3/4	R3/4	R3/4
	Exhaust drain port	mm	25	25	25
Indoor/outdoor capacity ratio			50-200% <sup>3</sup>	50-200% <sup>3</sup>	50-200% <sup>3</sup>
Number of connected indoor units			24	24	24

Solenoid valve kit		
KIT-P56HR3	KIT-P56HR3	3-Pipe control Solenoid valve kit (up to 5,6kW)
	CZ-P56HR3	Solenoid valve kit (up to 5,6kW)
	CZ-CAPE2	3-Pipe control PCB
KIT-P160HR3	KIT-P160HR3	3-Pipe control Solenoid valve kit (from 5,6kW to 10,6kW)
	CZ-P160HR3	Solenoid valve kit (from 5,6kW to 10,6kW)
	CZ-CAPE2	3-Pipe control PCB
CZ-CAPE2		3-Pipe control PCB for wall mounted

GHP Service kits model name	Kit CZ-PSK560S
Outdoor unit reference	U-16GF2E5 / U-20GF2E5 / U-25GF2E5
Material included on the kit	
Oil Filter	1
Air Cleaner Element (Air Filter)	1
Plug	4
V BELT (for compressor)	1
V Belt (for generator)	-
Oil Strainer	1
Drain Filter Packing	1

Rating Conditions: Cooling Indoor 27°C DB / 19°C WB. Cooling Outdoor 35°C DB. Heating (standard) Indoor 20°C DB. Heating (standard) Outdoor 7°C DB / 6°C WB. Heating (low temp.) Indoor 20°C DB / 15°C WB or less. Heating (low temp.) Outdoor 2°C DB / 1°C WB. DB: Dry Bulb; WB: Wet Bulb

1) Referred to Natural Gas (HCV=55,489 MJ/kg; LCV=50,013 MJ/kg). 2) Low temperature condition: outdoor temperature 2°C. 3) Indoor unit can be connected to up to 16 kW model (model size 60) Specifications subject to change without notice.

Cooling and heating capacities in the tables are determined under the test conditions of JIS B 8627. Effective heating requires that the outdoor air intake temperature be at least -20°C DB or -21°C WB.

- Gas consumption is the total (high) calorific value standard. - Outdoor unit operating sound is measured 1 meter from the front and 1.5 meters above the floor (in an anechoic environment). Actual installations may have larger values due to ambient noise and reflections. - Specifications are subject to change without notice. - Hot water heating capacity is applicable during cooling operation. - The maximum water temperature that can be obtained is 75°C. Water heating performance and temperature vary with the air conditioning load. Because the hot water heating system uses waste heat from the engine, which runs the air conditioning, its ability to heat water is not guaranteed.





**U-16GF2E5 // U-20GF2E5 // U-25GF2E5**

**Technical focus**

- Simultaneous heating and cooling for total control
- Reduced gas consumption by Miller-cycle engine
- Reduced electrical power consumption by using DC Motors
- Part load efficiencies increased
- Connectability increased to up to 24 indoor units
- 145 m maximum allowable piping length, L1
- Capacity ratio 50–200%
- Extended pipe runs (total 780 m)
- Quiet mode offers a further 2 dB(A) reduction
- Full heating capacity down to -21°C
- Option of using LPG as a power supply (increases flexibility and avoids problems of potential site restrictions in the future. The purer fuel is also excellent for further reductions in CO<sub>2</sub> emissions)

- No defrost cycle
- 10,000 run hours between engine service intervals (equivalent to one maintenance every 3.2 years\*)

\* Assuming 3,120 running hours per year - 12 h x 5 days x 52 weeks

**Additional parts**

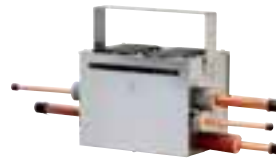

**3-Pipe control Solenoid valve kit**  
 CZ-P56HR3: Up to 5.6 kW  
 CZ-P160HR3: From 5.7 to 16 kW  
 KIT-P56HR3: (CZ-P56HR3+CZ-CAPE2)  
 KIT-P160HR3: (CZ-P160HR3+CZ-CAPE2)

\* For conference rooms and other locations where low noise is required, pay attention to the installation location and install in a corridor etc.



**3-Pipe control PCB CZ-CAPE2\*.**

Must be added to the CZ-P56HR3 OR CZ-P160HR3.  
 \* For wall mounted.

**SERVICE CLEARANCES FOR INSTALLATION**

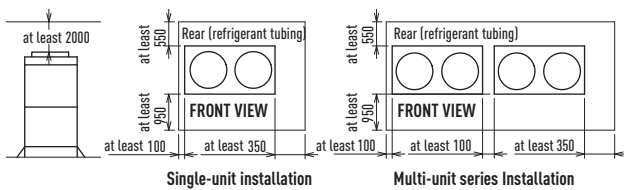

**TOP VIEW**

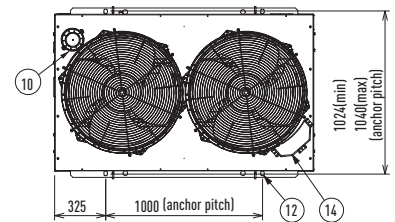

kW		45.0	56.0-71.0
1	Suction refrigerant pipe	Ø 22.22	Ø 28.58
2	Discharge refrigerant pipe	Ø 22.22	Ø 25.4
3	Liquid refrigerant pipe	19.05	
4	Exhaust gas drain port	HOSE OD Ø 25 (accessory)	
5	Electrical power supply port	Ø 28	
6	Inter-unit cable port	Ø 28	
7	Fuel gas port	R3/4	
8	Condensation drain opening	Ø 20	
9	Rain and condensation outlet		
10	Engine exhaust outlet		
11	Suspension holes 4-Ø 20x30		
12	Anchor holes 4-Ø 22x30		
13	Segmented display		
14	Coolant intake (top)		
15	Vent		

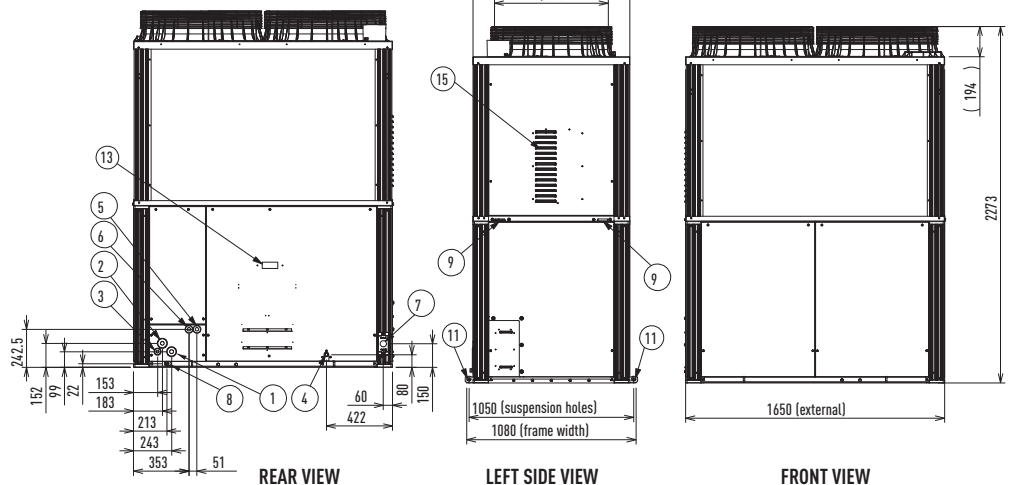



## Indoor units for ECO G

Wide choice of models depending on the indoor requirements.



## 4 Way 90x90 Cassette

### Wide & Comfortable Airflow

This proprietary design has wide-angle discharge outlets and flaps are larger in the middle, featuring a shape based on a combination of geometrics and the testing of prototype units. Air coming out of the center of the discharge outlets travels farther. From the sides of each outlet, where the openings are larger, airflow spreads out to reach the corners of the room. Air is discharged across a wide area from the four sides of the unit.

The curves on the room temperature distribution graph expand gently out through 360° in a circle centered on the indoor unit.

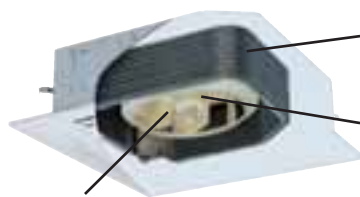

**Higher efficiency split fin.**

Improved heat-transfer coefficient due to adoption of high efficiently grooved heat exchanger tube.

**New DC-Fan motor.**

It is realized more optimum air-flow by a new DC-fan motor with independent control.

**Individual flap control.**

Flexible Air flow direction control by individual flap control is possible. 4 Flaps can be controlled individually by setting on wired timer remote controller. Several demands can be accommodated in one space.

**High-efficient & Silent turbo Fan.**

It is realized more air volume and more silent due to new development of a bigger fan chassis than previous one and optimization design of airflow path.

### New 360° Air Flow for better comfort

By redesigning the air-outlet and flap, Soft & 3D air flow circulates whole space and provides even temperature distribution in the room.

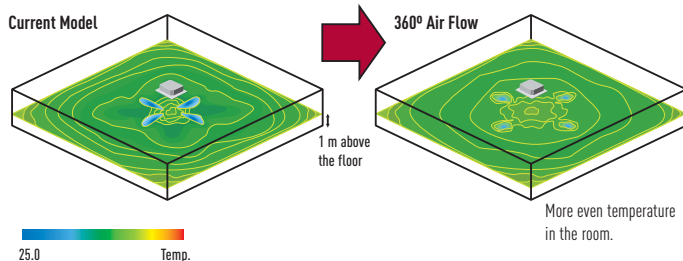

Simulated condition: Floor area: 225 m<sup>2</sup>. Ceiling height: 3 m, Unit 5 HP type.

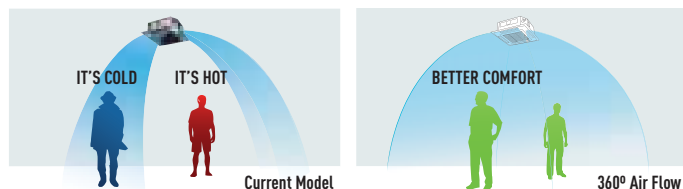

### Flexible 3D air-flow control

Comfort air flow control & proper energy use. Flexible Air flow direction control by individual flap control:

- 4 Flaps can be controlled individually (by standard wired remote controller\*).
- It can make more flexible Air-flow control to be matched to several demands can be accommodated in one space.

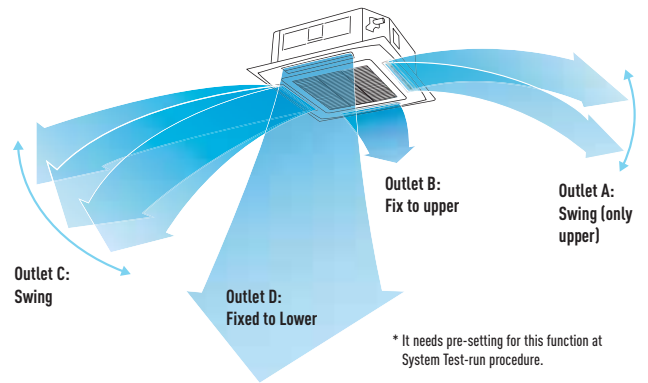

### New design

Wide direction air discharge by outlet design.

The Circle Flow Flap and redesigned air outlet eliminate airflow along recessed parts on the ceiling to reduce contamination. If air flows only along these recessed parts, they will quickly become dirty. These new features greatly reduce accumulations of dirt.

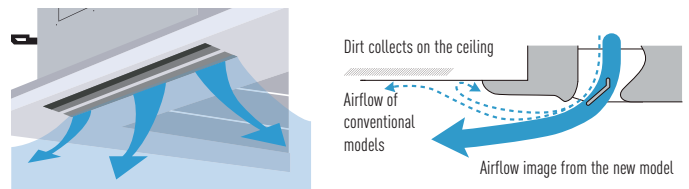





## ECO G systems indoor units range

	1,5 kW	2,2 kW	2,8 kW	3,0 kW	3,6 kW	4,0 kW	4,5 kW
U1 Type // 4 Way 90x90 Cassette		 S-22MU1E5A	 S-28MU1E5A		 S-36MU1E5A		 S-45MU1E5A
Y2 TYPE // 4 Way 60x60 Cassette	 S-15MY2E5A	 S-22MY2E5A	 S-28MY2E5A		 S-36MY2E5A		 S-45MY2E5A
L1 Type // 2 Way Cassette		 S-22ML1E5	 S-28ML1E5		 S-36ML1E5		 S-45ML1E5
D1 Type // 1 Way Cassette			 S-28MD1E5		 S-36MD1E5		 S-45MD1E5
F2 Type // Variable Static Pressure Hide Away	 S-15MF2E5A	 S-22MF2E5A	 S-28MF2E5A		 S-36MF2E5A		 S-45MF2E5A
M1 Type // Slim Variable Static Pressure Hide Away	 S-15MM1E5A	 S-22MM1E5A	 S-28MM1E5A		 S-36MM1E5A		 S-45MM1E5A
E2 Type // High Static Pressure Hide Away							
Heat Recovery With DX Coil				 PAW-500ZDX2		 PAW-800ZDX2	 PAW-01KZDX2
T2 Type // Ceiling					 S-36MT2E5A		 S-45MT2E5A
K2/K1 Type // Wall Mounted	 S-15MK2E5A	 S-22MK2E5A	 S-28MK2E5A		 S-36MK2E5A		 S-45MK1E5A
P1 Type // Floor Standing		 S-22MP1E5	 S-28MP1E5		 S-36MP1E5		 S-45MP1E5
R1 Type // Concealed Floor Standing		 S-22MR1E5	 S-28MR1E5		 S-36MR1E5		 S-45MR1E5

Wide choice of models depending on the indoor requirements.

5,6 kW	6,0 kW	7,3 kW	9,0 kW	10,6 kW	14,0 kW	16,0 kW	22,4 kW	28,0 kW
 S-56MU1E5A	 S-60MU1E5A	 S-73MU1E5A	 S-90MU1E5A	 S-106MU1E5A	 S-140MU1E5A	 S-160MU1E5A		
 S-56MY2E5A								
 S-56ML1E5		 S-73ML1E5						
 S-56MD1E5		 S-73MD1E5						
 S-56MF2E5A	 S-60MF2E5A	 S-73MF2E5A	 S-90MF2E5A	 S-106MF2E5A	 S-140MF2E5A	 S-160MF2E5A		
 S-56MM1E5A								
							 S-224ME2E5 S-224ME1E5A	 S-280ME2E5 S-280ME1E5
 S-56MT2E5A		 S-73MT2E5A		 S-106MT2E5A	 S-140MT2E5A			
 S-56MK1E5A		 S-73MK1E5A		 S-106MK1E5A				
 S-56MP1E5		 S-71MP1E5						
 S-56MR1E5		 S-71MR1E5						

**U1 TYPE**  
4 WAY 90X90 CASSETTE  
SEMI CONCEALED  
CASSETTE



The award winning range of U1 type cassettes are smaller, shallower and lighter than previous models and feature a 950 x 950mm panel throughout. The DC fan motor and air discharge louvre ensure quiet, optimum air distribution.

**A drain height of approx. 850mm from the ceiling surface**

The drain height can be increased by approximately 350mm over the conventional value by using a high-lift drain pump, and long horizontal piping is possible.

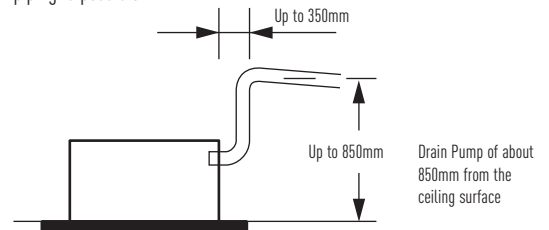

**Technical focus**

- Compact design
- Reduced sound levels (from previous models)
- DC fan motor for increased efficiency
- Powerful drain pump gives 850mm lift
- Lightweight design
- Fresh air knockout
- Branch duct connection
- Optional air-intake plenum CZ-FDU2

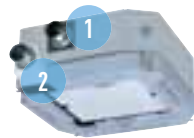

**Air intake chamber**

1. Air intake box CZ-BCU2 for main unit.
2. Air intake box CZ-ATU2\* for Air intake plenum. CZ-CFU2 Part to close air flow for the cassette 90x90 series U1.

\* When using Air intake box (CZ-ATU2), Air intake plenum (CZ-FDU2) is required.



Panel  
CZ-KPU21



Optional Controller  
Wired remote controller  
CZ-RTC3



Optional Controller  
Timer remote controller  
CZ-RTC2



Optional Controller  
Wireless remote controller  
CZ-RWSU2



Optional Controller  
Simplified remote controller  
CZ-RE2C2

Model <sup>1)</sup>		S-22MU1E5A	S-28MU1E5A	S-36MU1E5A	S-45MU1E5A	S-56MU1E5A	S-60MU1E5A	S-73MU1E5A	S-90MU1E5A	S-106MU1E5A	S-140MU1E5A	S-160MU1E5A	
Power source		230 V / Single Phase / 50 Hz											
Cooling capacity	kW	2,2	2,8	3,6	4,5	5,6	6,0	7,3	9,0	10,6	14,0	16,0	
Power input cooling	W	20	20	20	20	25	35	40	40	95	100	115	
Operating current cooling	A	0,19	0,19	0,19	0,19	0,22	0,31	0,33	0,36	0,71	0,76	0,89	
Heating capacity	kW	2,5	3,2	4,2	5,0	6,3	7,1	8,0	10,0	11,4	16,0	18,0	
Power input heating	W	20	20	20	20	25	35	40	40	85	100	105	
Operating current heating	A	0,17	0,17	0,17	0,17	0,20	0,30	0,32	0,34	0,65	0,73	0,80	
Fan type		Turbo fan	Turbo fan	Turbo fan	Turbo fan	Turbo fan	Turbo fan	Turbo fan	Turbo fan	Turbo fan	Turbo fan	Turbo fan	
Air volume	Hi / Med / Lo	m <sup>3</sup> /h	840/720/660	840/720/660	840/720/660	900/780/720	960/810/720	1.260/1.020/840	1.320/1.020/840	1.380/1.140/900	1.980/1.620/1.260	2.100/1.680/1.320	2.160/1.740/1.380
Sound pressure level	Lo / Med / Hi	dB(A)	28 / 29 / 30	28 / 29 / 30	28 / 29 / 30	28 / 29 / 31	28 / 30 / 33	29 / 32 / 36	29 / 32 / 37	32 / 35 / 38	34 / 38 / 44	35 / 39 / 45	38 / 40 / 46
Dimensions	H x W x D	mm	256 (+33,5) x 840 (950) x 840 (950)										
Pipe connections	Liquid	inch (mm)	1/4 (6,35)	1/4 (6,35)	1/4 (6,35)	1/4 (6,35)	1/4 (6,35)	3/8 (9,52)	3/8 (9,52)	3/8 (9,52)	3/8 (9,52)	3/8 (9,52)	3/8 (9,52)
	Gas	inch (mm)	1/2 (12,7)	1/2 (12,7)	1/2 (12,7)	1/2 (12,7)	1/2 (12,7)	5/8 (15,88)	5/8 (15,88)	5/8 (15,88)	5/8 (15,88)	5/8 (15,88)	5/8 (15,88)
	Drain piping		VP-25	VP-25	VP-25	VP-25	VP-25	VP-25	VP-25	VP-25	VP-25	VP-25	VP-25
Net weight	kg	23	23	23	23	23	24	24	24	27	27	27	

Rating Conditions: Cooling Indoor 27°C DB / 19°C WB. Cooling Outdoor 35°C DB / 24°C WB. Heating Indoor 20°C DB. Heating Outdoor 7°C DB / 6°C WB.  
DB: Dry Bulb; WB: Wet Bulb.

1) Available from April 2014.

Optional

<b>Internet Control Ready</b>	<b>Energy saving</b>	<b>Environmentally friendly refrigerant</b>	<b>Easy maintenance</b>	<b>For more comfort</b>	<b>Perfect humidity control</b>	<b>Further comfort</b>	<b>Practical operation</b>	<b>Comfort everywhere</b>	<b>Easy to install</b>	<b>Easy control by BMS</b>
INTERNET CONTROL	INVERTER+	R410A	SELF-DIAGNOSING	AUTOMATIC FAN	MILD DRY	AUTO-FLAP CONTROL	AUTOMATIC RESTART	AIR SWEEP	BUILT-IN DRAIN PUMP	CONNECTIVITY



# Y2 TYPE 4 WAY 60X60 CASSETTE MINI SEMI CONCEALED CASSETTE



Designed to fit exactly into a 600 x 600mm ceiling grid without the need to alter the bar configuration, the Y2 is ideal for small commercial and retrofit applications. In addition, the improvements to efficiency make this one of the most advanced units in the industry.

### Technical focus

- Mini cassette fits into a 600 x 600mm ceiling grid
- Fresh air knock out
- Multidirectional air flow
- Powerful drain pump gives 850mm lift
- Turbo fans and heat exchanger fins with improved design
- DC fan motors with variable speed, new heat exchangers, etc. ensure an efficient power consumption

### Special designed flap

The flap can be removed easily for washing with water.



### A drain height of approx. 850mm from the ceiling surface

The drain height can be increased by approximately 350mm over the conventional value by using a high-lift drain pump, and long horizontal piping is possible.

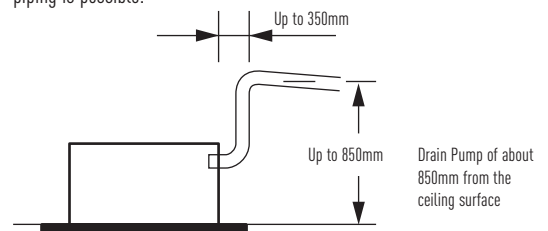

A lightweight unit at 18.4 kg the unit is also very slim with a height of only 288mm, making installation possible even in narrow ceilings.

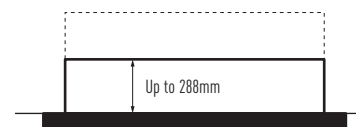

**Panel**  
CZ-KPY3A (size 700 x 700mm)  
CZ-KPY3B (size 625 x 625mm)



**Optional Controller**  
Wired remote controller  
CZ-RTC3



**Optional Controller**  
Timer remote controller  
CZ-RTC2



**Optional Controller**  
Wireless remote controller  
CZ-RWSK2



**Optional Controller**  
Simplified remote controller  
CZ-RE2C2

Model <sup>1</sup>		S-15MY2E5A	S-22MY2E5A	S-28MY2E5A	S-36MY2E5A	S-45MY2E5A	S-56MY2E5A	
Power source		230 V / Single Phase / 50 Hz						
Cooling capacity	kW	1,5	2,2	2,8	3,6	4,5	5,6	
Power input cooling	W	35	35	35	40	40	45	
Operating current cooling	A	0,30	0,30	0,30	0,30	0,32	0,35	
Heating capacity	kW	1,7	2,5	3,2	4,2	5,0	6,3	
Power input heating	W	30	30	30	35	35	40	
Operating current heating	A	0,25	0,25	0,30	0,30	0,30	0,30	
Fan type		Centrifugal fan						
Air volume (Hi / Med / Lo)	Cooling	m <sup>3</sup> /h	534 / 492 / 336	546 / 492 / 336	558 / 504 / 336	582 / 522 / 360	600 / 558 / 492	624 / 588 / 510
	Heating	m <sup>3</sup> /h	546 / 504 / 336	558 / 504 / 336	576 / 522 / 336	594 / 546 / 360	618 / 576 / 492	666 / 588 / 522
Sound pressure level (Lo / Med / Hi)	Cooling	dB(A)	25 / 33 / 34	25 / 33 / 35	25 / 33 / 35	26 / 34 / 36	33 / 36 / 38	34 / 37 / 40
	Heating	dB(A)	25 / 33 / 34	25 / 33 / 35	25 / 33 / 35	26 / 34 / 36	32 / 36 / 38	34 / 37 / 40
Dimensions		H x W x D mm 288 x 583 x 583						
Pipe connections	Liquid	inch (mm)	1/4 (6,35)	1/4 (6,35)	1/4 (6,35)	1/4 (6,35)	1/4 (6,35)	
	Gas	inch (mm)	1/2 (12,7)	1/2 (12,7)	1/2 (12,7)	1/2 (12,7)	1/2 (12,7)	
	Drain piping		VP-25	VP-25	VP-25	VP-25	VP-25	
Net weight		kg 20,4 (18 + 2,4)						

Rating Conditions: Cooling Indoor 27°C DB / 19°C WB. Cooling Outdoor 35°C DB / 24°C WB. Heating Indoor 20°C DB. Heating Outdoor 7°C DB / 6°C WB.  
DB: Dry Bulb; WB: Wet Bulb.

1) Available from April 2014.

### Optional

<b>Internet Control Ready</b> INTERNET CONTROL	<b>Energy saving</b> INVERTER+	<b>Environmentally friendly refrigerant</b> R410A	<b>Easy maintenance</b> SELF-DIAGNOSING	<b>For more comfort</b> AUTOMATIC FAN	<b>Perfect humidity control</b> MILD DRY	<b>Further comfort</b> AUTO-FLAP CONTROL	<b>Practical operation</b> AUTOMATIC RESTART	<b>Comfort everywhere</b> AIR SWEEP	<b>Easy to install</b> BUILT-IN DRAIN PUMP	<b>Easy control by BMS</b> CONNECTIVITY
---	-----------------------------------	--	--	--	---	---	---	--	---	--

L1 TYPE  
2 WAY CASSETTE



Slim, compact and lightweight units. Remarkable size and weight reductions have been achieved by improvement of the design around the fan, the weight of all models now being 30 kg.

**Technical focus**

- Airflow and distribution is automatically altered depending on the operational mode of the unit
- Drain up is possible up to 500mm from the drain port
- Simple maintenance

**Simple maintenance**

The drain pan is equipped with site wiring and can be removed. The fan case has a split construction, and the fan motor can be removed easily when the lower case is removed.

**Airflow and distribution is automatically altered depending on the operational mode of the unit.**

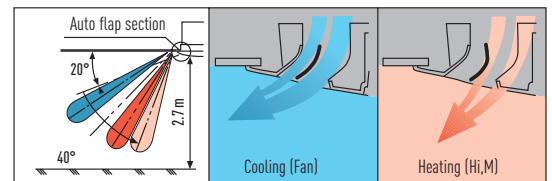

**Drain up is possible up to 500mm from the drain port.**

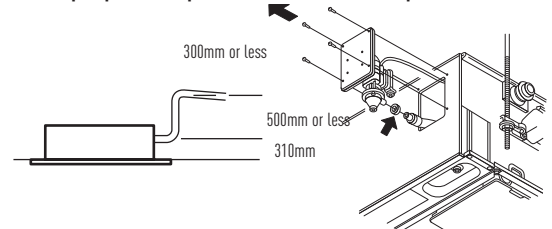

Maintenance of the drain pump is possible from two sides, from the left side (piping side) and from the inside of the unit.



**PANEL**  
CZ-02KPL2  
CZ-03KPL2 (for S-73ML1E5)



**Optional Controller**  
Wired remote controller  
CZ-RTC3



**Optional Controller**  
Timer remote controller  
CZ-RTC2



**Optional Controller**  
Wireless remote controller  
CZ-RWSL2



**Optional Controller**  
Simplified remote controller  
CZ-RE2C2

Model		S-22ML1E5	S-28ML1E5	S-36ML1E5	S-45ML1E5	S-56ML1E5	S-73ML1E5
Power source		230 V / Single Phase / 50 Hz					
Cooling capacity	kW	2,2	2,8	3,6	4,5	5,6	7,3
Power input cooling	W	90	92	93	97	97	145
Operating current cooling	A	0,45	0,45	0,45	0,45	0,45	0,65
Heating capacity	kW	2,5	3,2	4,2	5,0	6,3	8,0
Power input heating	W	58	60	61	65	65	109
Operating current heating	A	0,29	0,29	0,29	0,29	0,29	0,48
Fan type		Sirocco fan					
Air volume	Hi / Med / Lo m <sup>3</sup> /h	480 / 420 / 360	540 / 480 / 420	580 / 520 / 460	660 / 540 / 480	660 / 540 / 480	1.140 / 960 / 840
Sound pressure level	Lo / Med / Hi dB(A)	24 / 27 / 30	26 / 29 / 33	28 / 31 / 34	29 / 33 / 35	29 / 33 / 35	33 / 35 / 38
Dimensions	H x W x D mm	350(+8)x840 (1.060)x600 (680)	350(+8)x840 (1.060)x600 (680)	350(+8)x840 (1.060)x600 (680)	350(+8)x840 (1.060)x600 (680)	350(+8)x840 (1.060)x600 (680)	350(+8)x1.140 (1.360)x600 (680)
Pipe connections	Liquid inch (mm)	1/4 (6,35)	1/4 (6,35)	1/4 (6,35)	1/4 (6,35)	1/4 (6,35)	3/8 (9,52)
	Gas inch (mm)	1/2 (12,7)	1/2 (12,7)	1/2 (12,7)	1/2 (12,7)	1/2 (12,7)	5/8 (15,88)
	Drain piping	VP-25	VP-25	VP-25	VP-25	VP-25	VP-25
Net weight	kg	28,5 (23 + 5,5)	28,5 (23 + 5,5)	28,5 (23 + 5,5)	28,5 (23 + 5,5)	28,5 (23 + 5,5)	39 (30 + 9)

Rating Conditions: Cooling Indoor 27°C DB / 19°C WB. Cooling Outdoor 35°C DB / 24°C WB. Heating Indoor 20°C DB. Heating Outdoor 7°C DB / 6°C WB.  
DB: Dry Bulb; WB: Wet Bulb.

Optional

<b>Internet Control Ready</b>	<b>Energy saving</b>	<b>Environmentally friendly refrigerant</b>	<b>Easy maintenance</b>	<b>For more comfort</b>	<b>Perfect humidity control</b>	<b>Further comfort</b>	<b>Practical operation</b>	<b>Comfort everywhere</b>	<b>Easy to install</b>	<b>Easy control by BMS</b>
INTERNET CONTROL	INVERTER+	R410A	SELF-DIAGNOSING	AUTOMATIC FAN	MILD DRY	AUTO-FLAP CONTROL	AUTOMATIC RESTART	AIR SWEEP	BUILT-IN DRAIN PUMP	CONNECTIVITY

# D1 TYPE 1 WAY CASSETTE



Designed for installation within the ceiling void, the D1 range of slimline 1 way blow cassettes feature powerful yet quiet fans for up to 4.2 m.

### Technical focus

- Ultra-Slim
- Suitable for standard and high ceilings
- Built-in drain pump provides 590mm lift
- Easy to install and maintain
- Hanging height can be easily adjusted
- Uses a DC fan motor to improve energy-efficiency

### Drain height

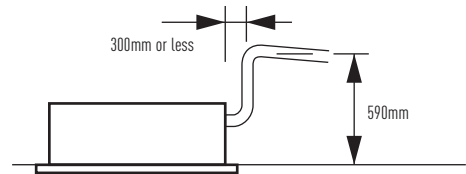

Panel  
CZ-KPD2



Optional Controller  
Wired remote controller  
CZ-RTC3



Optional Controller  
Timer remote controller  
CZ-RTC2



Optional Controller  
Wireless remote controller  
CZ-RWST2



Optional Controller  
Simplified remote controller  
CZ-RE2C2

Model		S-28MD1E5	S-36MD1E5	S-45MD1E5	S-56MD1E5	S-73MD1E5
Power source		230 V / Single Phase / 50 Hz				
Cooling capacity	kW	2,8	3,6	4,5	5,6	7,3
Power input cooling	W	51	51	51	60	87
Operating current cooling	A	0,39	0,39	0,39	0,46	0,7
Heating capacity	kW	3,2	4,2	5,0	6,3	8,0
Power input heating	W	40	40	40	48	76
Operating current heating	A	0,35	0,35	0,35	0,41	0,65
Fan type		Sirocco fan	Sirocco fan	Sirocco fan	Sirocco fan	Sirocco fan
Air volume	Hi / Med / Lo	m <sup>3</sup> /h	720 / 600 / 540	720 / 600 / 540	720 / 660 / 600	780 / 690 / 600
Sound pressure level	Lo / Med / Hi	dB(A)	33 / 34 / 36	33 / 34 / 36	34 / 35 / 36	34 / 36 / 38
Dimensions	H x W x D	mm	200 (+20)x1.000 (1.230)x710 (800)	200 (+20)x1.000 (1.230)x710 (800)	200 (+20)x1.000 (1.230)x710 (800)	200 (+20)x1.000 (1.230)x710 (800)
Pipe connections	Liquid	inch (mm)	1/4 (6,35)	1/4 (6,35)	1/4 (6,35)	1/4 (6,35)
	Gas	inch (mm)	1/2 (12,7)	1/2 (12,7)	1/2 (12,7)	1/2 (12,7)
	Drain piping		VP-25	VP-25	VP-25	VP-25
Net weight	kg	26,5 (21 + 5,5)	26,5 (21 + 5,5)	26,5 (21 + 5,5)	26,5 (21 + 5,5)	27,5 (22 + 5,5)

Rating Conditions: Cooling Indoor 27°C DB / 19°C WB. Cooling Outdoor 35°C DB / 24°C WB. Heating Indoor 20°C DB. Heating Outdoor 7°C DB / 6°C WB.  
DB: Dry Bulb; WB: Wet Bulb.

### Optional

Internet Control Ready INTERNET CONTROL	Energy saving INVERTER+	Environmentally friendly refrigerant R410A	Easy maintenance SELF-DIAGNOSING	For more comfort AUTOMATIC FAN	Perfect humidity control MILD DRY	Further comfort AUTO-FLAP CONTROL	Practical operation AUTOMATIC RESTART	Comfort everywhere AIR SWEEP	Easy to install BUILT-IN DRAIN PUMP	Easy control by BMS CONNECTIVITY
--	----------------------------	---	-------------------------------------	-----------------------------------	--------------------------------------	--------------------------------------	--	---------------------------------	--	-------------------------------------

# F2 TYPE VARIABLE STATIC PRESSURE HIDE AWAY



S-15MF2E5A // S-22MF2E5A // S-28MF2E5A // S-36MF2E5A // S-45MF2E5A // S-56MF2E5A

S-60MF2E5A // S-73MF2E5A // S-90MF2E5A

S-106MF2E5A // S-140MF2E5A // S-160MF2E5A

The new F2 type is designed specifically for applications requiring fixed square ducting. The internal filter is equipped as standard.

### Technical focus

- Industry-leading low sound levels from 25 dB(A)
- Built-in drain pump provides 785mm lift
- Easy to install and maintain
- Air OFF sensor avoids cold air dumping
- Configurable air temperature control

### More powerful drain pump

Using a high-lift drain pump, drain piping can be elevated up to 785mm from the base of the unit.

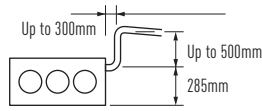

### Air Outlet & Inlet Plenum

S-...MF2E5A	Diameters	Air Outlet Plenum	Diameters	Air Inlet Plenum
22, 28, 36, 45 & 56	2 x Ø 200	CZ-56DAF2	2 x Ø 200	CZ-DUMPA56MF2
60, 73 & 90	3 x Ø 200	CZ-90DAF2	2 x Ø 250	CZ-DUMPA90MF2
106, 140 & 160	4 x Ø 200	CZ-160DAF2	4 x Ø 200	CZ-DUMPA160MF2



### New Variable Static Pressure Hide Away MF2 series

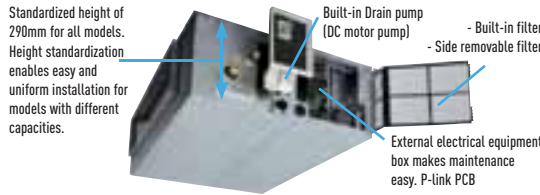

### Full range of External Static Pressure and Airflow Volumes available by special setting

To meet all design needs thanks to DC fan motor it is possible to select the best fitted airflow/ static pressure curve.

The table below shows the airflow and noise data at minimum airflows curve selectable (Example S-22MF2E5A: see red dot in the diagram n.1)

and noise data at maximum rated static pressure with maximum airflow curve selectable (example S-22MF2E5A blu dot in diagram n.1). Specific diagrams per each units are available in ECOi Technical Data Book.

Model		15-36	45	56	60-73	90	106	140	160
Minimum air volume - the red dot - on minimum airflow curve selectable (curve 1-3)	m³/h	480	480	600	780	960	1.140	1.200	1.320
Min Static Pressure value - the red dot - on minimum airflow curve selectable (curve 1-3)	Pa	15	15	15	10	10	20	15	15
Noise level at minimum static pressure - the red dot - on minimum airflow curve selectable (curve 1-3)	dB(A)	24	26	26	24	26	29	30	31
Noise level at maximum rated static pressure - the blue dot - on maximum airflow curve selectable (curve 15)	dB(A)	34	35	35	40	41	42	42	43

### F2 Advantages

Automatic learning function for the required static pressure, to be activated easily by the standard wired timer remote controller. Possible to increase the sensible cooling capacity by adjusting the air volume flow in order to almost completely eliminate latent losses. This is possible due to the outstanding big heat exchanger surface in combination with increasing the air volume flow by a manual selection of higher fan speed curves through the standard wired remote controller when commissioning the system together with the default active off-coil temperature control and the room load based variable evaporation temperature control.

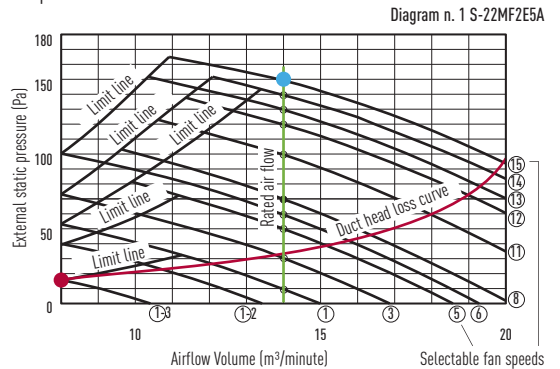

Optional Controller  
Wired remote controller  
CZ-RTC3



Optional Controller  
Timer remote controller  
CZ-RTC2



Optional Controller  
Wireless remote controller  
CZ-RWSK2 + CZ-RWSC3



Optional Controller  
Simplified remote controller  
CZ-RE2C2

Model <sup>1</sup>	S-15MF2E5A	S-22MF2E5A	S-28MF2E5A	S-36MF2E5A	S-45MF2E5A	S-56MF2E5A	S-60MF2E5A	S-73MF2E5A	S-90MF2E5A	S-106MF2E5A	S-140MF2E5A	S-160MF2E5A		
Power source	230 V / Single Phase / 50 Hz													
Cooling capacity	kW	1,5	2,2	2,8	3,6	4,5	5,6	6,0	7,3	9,0	10,6	14,0	16,0	
Power input cooling	W	70	70	70	70	70	100	120	120	135	195	215	225	
Operating current cooling	A	0,57	0,57	0,57	0,57	0,57	0,74	0,89	0,89	0,97	1,30	1,44	1,50	
Heating capacity	kW	1,7	2,5	3,2	4,2	5,0	6,3	7,1	8,0	10,0	11,4	16,0	18,0	
Power input heating	W	70	70	70	70	100	100	120	120	135	200	210	225	
Operating current heating	A	0,57	0,57	0,57	0,57	0,57	0,74	0,89	0,89	0,97	1,34	1,42	1,50	
Fan type	Sirocco fan													
Air volume <sup>2</sup>	Hi / Med / Lo	m³/h	840/780/540	840/780/540	840/780/540	840/780/540	840/780/600	960/900/720	1.260/1.140/900	1.260/1.140/900	1.500/1.380/1.140	1.920/1.560/1.260	2.040/1.740/1.380	2.160/1.920/1.500
External static pressure	Pa	70 (10-150)	70 (10-150)	70 (10-150)	70 (10-150)	70 (10-150)	70 (10-150)	70 (10-150)	70 (10-150)	70 (10-150)	100 (10-150)	100 (10-150)	100 (10-150)	
Sound power level <sup>3</sup>	Lo / Med / Hi	dB	44 / 51 / 55	44 / 51 / 55	44 / 51 / 55	44 / 51 / 55	47 / 54 / 56	47 / 54 / 56	48 / 54 / 57	50 / 56 / 59	53 / 56 / 60	54 / 57 / 61	55 / 58 / 62	
Sound pressure level <sup>3</sup>	Lo / Med / Hi	dB(A)	22 / 29 / 33	22 / 29 / 33	22 / 29 / 33	22 / 29 / 33	25 / 32 / 34	25 / 32 / 34	26 / 32 / 35	28 / 34 / 37	31 / 34 / 38	32 / 35 / 39	33 / 36 / 40	
Dimensions	H x W x D	mm	290x800x700	290x800x700	290x800x700	290x800x700	290x800x700	290x800x700	290x1.000x700	290x1.000x700	290x1.000x700	290x1.400x700	290x1.400x700	
Pipe connections	Liquid	inch (mm)	1/4 (6,35)	1/4 (6,35)	1/4 (6,35)	1/4 (6,35)	1/4 (6,35)	1/4 (6,35)	3/8 (9,52)	3/8 (9,52)	3/8 (9,52)	3/8 (9,52)	3/8 (9,52)	
	Gas	inch (mm)	1/2 (12,7)	1/2 (12,7)	1/2 (12,7)	1/2 (12,7)	1/2 (12,7)	1/2 (12,7)	5/8 (15,88)	5/8 (15,88)	5/8 (15,88)	5/8 (15,88)	5/8 (15,88)	
	Drain piping		VP-25	VP-25	VP-25	VP-25	VP-25	VP-25	VP-25	VP-25	VP-25	VP-25	VP-25	
Net weight	kg	29	29	29	29	29	29	34	34	34	46	46	46	

Rating Conditions: Cooling Indoor 27°C DB / 19°C WB. Cooling Outdoor 35°C DB / 24°C WB. Heating Indoor 20°C DB. Heating Outdoor 7°C DB / 6°C WB.  
DB: Dry Bulb; WB: Wet Bulb.

1) Available from April 2014. 2) Value referred to standard settings at shipment (H curve 8, M curve 5, L curve 1). 3) Sound pressure without refrigerant flow.

Optional

<b>Internet Control Ready</b> INTERNET CONTROL	<b>Energy saving</b> INVERTER+	<b>Environmentally friendly refrigerant</b> R410A	<b>Easy maintenance</b> SELF-DIAGNOSING	<b>For more comfort</b> AUTOMATIC FAN	<b>Perfect humidity control</b> MILD DRY	<b>Practical operation</b> AUTOMATIC RESTART	<b>Easy to install</b> BUILT-IN DRAIN PUMP	<b>Easy control by BMS</b> CONNECTIVITY
---	-----------------------------------	--	--	--	---	---	---	--



**M1 TYPE**  
SLIM VARIABLE STATIC  
PRESSURE HIDE AWAY  
CONCEALED DUCT



The ultra slim M1 type is one of the leading products of its type in the industry. With a depth of only 200mm it provides greater flexibility and can be used in far more applications. In addition, its high-efficiency and extremely quiet sound levels make it very popular with many users, including hotels and small offices.

**Technical focus**

- Ultra-slim profile: 200mm for all models
- DC fan motor greatly reduces power consumption
- Ideal for hotel application with very narrow false ceilings
- Easy maintenance and service by external electrical box
- 40 Pa static pressure enables ductwork to be fitted.
- Includes drain pump

**Air Outlet & Inlet Plenum**

S-...MM1E5A	Diameters	Air Outlet Plenum	Diameters	Air Inlet Plenum
22, 28 & 36	2 x Ø 200	CZ-DUMPA22MMS2	2 x Ø 200	CZ-DUMPA22MMR2
45 & 56	3 x Ø 160	CZ-DUMPA45MMS3	2 x Ø 200	CZ-DUMPA22MMR3

**Ultra-slim profile for all models**



**Drain pump with increased power!**

By adoption of a high-lift drain pump, the drain piping rise height can be increased to 785mm from the lower surface of the body.

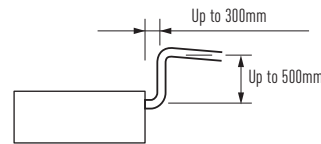

**Optional Controller**  
Wired remote controller  
CZ-RTC3



**Optional Controller**  
Timer remote controller  
CZ-RTC2



**Optional Controller**  
Wireless remote controller  
CZ-RWSK2 + CZ-RWSC3



**Optional Controller**  
Simplified remote controller  
CZ-RE2C2

Model <sup>1)</sup>		S-15MM1E5A*	S-22MM1E5A	S-28MM1E5A	S-36MM1E5A	S-45MM1E5A	S-56MM1E5A	
Power source		230 V / Single Phase / 50 Hz						
Cooling capacity	kW	1,5	2,2	2,8	3,6	4,5	5,6	
Power input cooling	W	36	36	40	42	49	64	
Operating current cooling	A	0,26	0,26	0,30	0,31	0,37	0,48	
Heating capacity	kW	1,7	2,5	3,2	4,2	5,0	6,3	
Power input heating	W	26	26	30	32	39	54	
Operating current heating	A	0,23	0,23	0,27	0,28	0,34	0,45	
Fan type		Sirocco fan						
Air volume	Hi / Med / Lo	m <sup>3</sup> /h	480 / 420 / 360	480 / 420 / 360	510 / 450 / 390	540 / 480 / 420	630 / 570 / 480	750 / 690 / 600
External static pressure		Pa	10 (30)	10 (30)	15 (30)	15 (40)	15 (40)	15 (40)
Sound pressure level	Lo / Med / Hi (2)	dB(A)	25 / 27 / 28 (27 / 29 / 30)	25 / 27 / 28 (27 / 29 / 30)	27 / 29 / 30 (29 / 31 / 32)	28 / 30 / 32 (30 / 32 / 34)	30 / 32 / 34 (32 / 34 / 36)	31 / 33 / 35 (32 / 35 / 37)
Dimensions	H x W x D	mm	200 x 750 x 640	200 x 750 x 640	200 x 750 x 640	200 x 750 x 640	200 x 750 x 640	200 x 750 x 640
Pipe connections	Liquid	inch (mm)	1/4 (6,35)	1/4 (6,35)	1/4 (6,35)	1/4 (6,35)	1/4 (6,35)	1/4 (6,35)
	Gas	inch (mm)	1/2 (12,7)	1/2 (12,7)	1/2 (12,7)	1/2 (12,7)	1/2 (12,7)	1/2 (12,7)
	Drain piping		VP-20	VP-20	VP-20	VP-20	VP-20	VP-20
Net weight		kg	19	19	19	19	19	19

Rating Conditions: Cooling Indoor 27°C DB / 19°C WB. Cooling Outdoor 35°C DB / 24°C WB. Heating Indoor 20°C DB. Heating Outdoor 7°C DB / 6°C WB.  
DB: Dry Bulb; WB: Wet Bulb.

1) Available from November 2014. 2) With booster cable using short circuit connection.

\* Tentative data.

Optional

<b>Internet Control Ready</b> INTERNET CONTROL	<b>Energy saving</b> INVERTER+	<b>Environmentally friendly refrigerant</b> R410A	<b>Easy maintenance</b> SELF-DIAGNOSING	<b>For more comfort</b> AUTOMATIC FAN	<b>Perfect humidity control</b> MILD DRY	<b>Practical operation</b> AUTOMATIC RESTART	<b>Comfort everywhere</b> AIR SWEEP	<b>Easy to install</b> BUILT-IN DRAIN PUMP	<b>Easy control by BMS</b> CONNECTIVITY
---	-----------------------------------	--	--	--	---	---	--	---	--

**E2 TYPE**  
HIGH STATIC PRESSURE  
HIDE AWAY



2 products in 1: High pressure duct and 100% Fresh air duct function. The E2 range of ducted units offers improved design flexibility for extended duct layouts as a result of their increased external static pressures and reduces energy consumption.

**Technical focus**

- **NEW!** No need of rap valve
- **NEW!** 100% Fresh air duct function
- **NEW!** DC fan motor for more savings
- Complete flexibility for ductwork design
- Can be located into a weatherproof housing for external siting
- Air OFF sensor avoids cold air dumping
- Configurable air temperature control

**System example**

An inspection port (450 x 450mm or more) is required at the lower side of the indoor unit body (field supply).

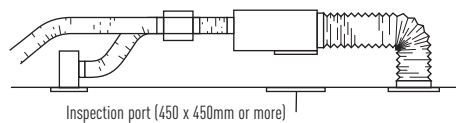

**100% Fresh air duct function**

The New E2 duct with 100% fresh air duct function have exceptional discharge temperature.

	Discharge Range		
	Min	Max	Default
Cooling	15°C	24°C	18°C
Heating	17°C	45°C	40°C

**Plenums**

Air Outlet Plenum (suitable for rigid + flexible duct)		
	N. of exits with diameters	Model
S-224ME1E5A / S-280ME1E5	1 x 500mm	CZ-TREMIESPW706



**Optional Controller**  
Wired remote controller  
CZ-RTC3



**Optional Controller**  
Timer remote controller  
CZ-RTC2



**Optional Controller**  
Wireless remote controller  
CZ-RWSK2 + CZ-RWSC3



**Optional Controller**  
Simplified remote controller  
CZ-RE2C2

		100% Fresh air duct function		High pressure duct	
Model		S-224ME2E5	S-280ME2E5	S-224ME1E5A	S-280ME1E5
Power source		230 V / Single Phase / 50 Hz		230 V / Single Phase / 50 Hz	
Cooling capacity	kW	22,4	28,0	22,4	28,0
Power input cooling	W	490	750	1.310	1.330
Operating current cooling	A	2,7	4,2	5,98	6,06
Heating capacity	kW	25,0	31,5	25,0	31,5
Power input heating	W	470	730	1.310	1.330
Operating current heating	A	2,6	4,1	5,98	6,06
Fan type		Sirocco fan		Sirocco fan	
Air volume	Hi / Med / Lo	m³/h 3.360 / 3.180 / 2.940		4.320 / 4.200 / 3.960	
External static pressure	Pa	140 (50 / 270) <sup>1)</sup>		216 (235) <sup>2)</sup>	
Sound pressure level <sup>3)</sup>	Lo / Med / Hi	dB(A) 47 / 46 / 44		49 / 50 / 51 (50 / 51 / 52) <sup>2)</sup>	
Dimensions	H x W x D	mm 467 x 1.428 x 1.230		479 x 1.428 x 1.230	
Pipe connections	Liquid	inch (mm) 3/8 (9,52)		3/8 (9,52)	
	Gas	inch (mm) 7/8 (22,22)		7/8 (22,22)	
	Drain piping	VP-25		VP-25	
Net weight	kg	105	110	120	120

Rating Conditions: Cooling Indoor 27°C DB / 19°C WB. Cooling Outdoor 35°C DB / 24°C WB. Heating Indoor 20°C DB. Heating Outdoor 7°C DB / 6°C WB.  
Rating Conditions for 100% Fresh air duct function: Cooling Outdoor 33°C DB / 28°C WB. Heating Outdoor 0°C DB / -2,9°C WB.  
DB: Dry Bulb; WB: Wet Bulb.

1) Available to select the setting by initial setup.  
2) With booster cable.  
3) Values with 140Pa setting.

Optional

<b>Internet Control Ready</b> INTERNET CONTROL	<b>Energy saving</b> INVERTER+	<b>Environmentally friendly refrigerant</b> R410A	<b>Easy maintenance</b> SELF-DIAGNOSING	<b>For more comfort</b> AUTOMATIC FAN	<b>Perfect humidity control</b> MILD DRY	<b>Practical operation</b> AUTOMATIC RESTART	<b>Easy control by BMS</b> CONNECTIVITY
---	-----------------------------------	--	--	--	---	---	--

# HEAT RECOVERY WITH DX COIL



**Optional Controller**  
Wired remote controller  
CZ-RTC3



**Optional Controller**  
Timer remote controller  
CZ-RTC2

### Technical focus

- Motorised heat recovery by-pass device automatically controlled by unit control to use fresh air free-cooling when convenient
- The Bioxygen® purifying system, activates when the fan runs, provides an efficient antibacterial treatment, ensuring optimum health of supplied air

### General characteristics

- Galvanized steel self-supporting panels, internally and externally insulated
- Counterflow air-to-air heat recovery device, made of sheets of special paper with special sealing to keep airflows separate and only permeable to water vapor. Total heat exchange with temperature efficiency up to 77% and enthalpy efficiency up to 63%, also at high level during summer season
- G4 efficiency class filters with synthetic cleanable media, both on fresh air and return air intake
- Removable side panel to access filters and heat recovery in the event of scheduled maintenance
- Low consumption, high efficiency & low noise direct driven fans with 3-speed EC motors
- Supply section complete with DX coil (R410A) fitted with solenoid control valve, freon filter, contact temperature sensors on liquid and gas line, NTC sensors upstream and downstream airflow
- Built-in electric box equipped with PCB to control internal fan speed and to interconnect outdoor/indoor units
- Duct connection by circular plastic collars
- CZ-RTC2 Timer remote controller (option)

### Balanced Ventilation

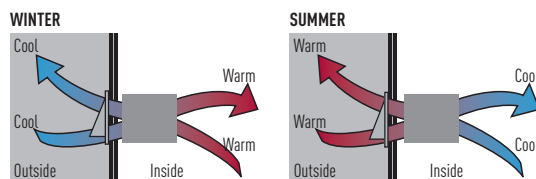

### Interconnection to outdoor/indoor units

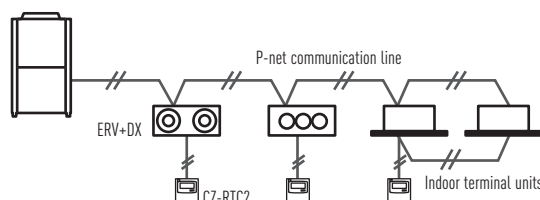

### Characteristic curves

The following curves show the unit external static pressure at maximum fan speed for each model.

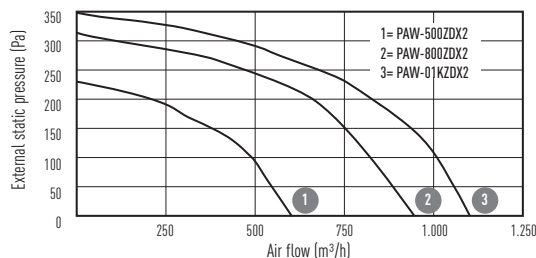

Model <sup>1</sup>		PAW-500ZDX2	PAW-800ZDX2	PAW-01KZDX2
Power source		230 V / Single Phase / 50 Hz	230 V / Single Phase / 50 Hz	230 V / Single Phase / 50 Hz
Air volume	Hi / Med / Lo	m <sup>3</sup> /h 500 / 500 / 360	800 / 800 / 625	1.000 / 780 / 650
External static pressure <sup>2</sup>	Hi / Med / Lo	Pa 85 / 45 / 21	117 / 68 / 18	104 / 69 / 17
Maximum current		A 1,1	2,3	2,5
Maximum power input		W 135	300	310
Sound pressure level <sup>3</sup>	Hi / Med / Lo	dB(A) 33 / 31 / 27	38 / 36 / 32	39 / 37 / 33
Pipe connections	Liquid / Gas	inch (mm) 1/4 (6,35) / 1/2 (12,7)	1/4 (6,35) / 1/2 (12,7)	1/4 (6,35) / 1/2 (12,7)
<b>HEAT RECOVERY</b>				
Temperature efficiency summer mode	%	62,5	59	59,5
Enthalpy efficiency summer mode	%	60	57	57,5
Saved power summer mode	kW	1,7	2,5	3,2
Temperature efficiency winter mode	%	76,5 (76,5)	73 (73)	73,5 (73,5)
Enthalpy efficiency winter mode	%	62,3 (64,1)	59 (60,8)	59,5 (61,2)
Saved power winter mode	kW	4,3 (4,8)	6,5 (7,3)	8,2 (9,0)
<b>DX COIL</b>				
Total cooling capacity	kW	3,7	4,9	5,6
Sensible cooling capacity	kW	2,3	3,3	3,8
Off temperature	Cooling °C	14,4	16,2	17,0
Off relative humidity	Cooling %	87	83	82
Total heating capacity	kW	3,9 (4,1)	5,4 (5,7)	6,3 (6,7)
Off temperature	Heating °C	35,4 (34,6)	32,6 (31,7)	31,3 (30,3)
Off relative humidity	Heating %	11 (11)	12 (13)	13 (14)

Nominal summer conditions: Outside air: 32°C DB, RH 50%. Ambient air: 26°C DB, RH 50%. Nominal winter conditions: Outside air: -5°C (-10°C) DB, RH 80%. Ambient air: 20°C DB, RH 50%. Cooling mode air inlet condition: 28.5°C DB, RH 50%; evaporating temp. 4°C. Heating mode air inlet condition: 13°C DB, RH 40% (11°C DB, RH 45%); condensating temperature 49°C. DB: Dry Bulb; RH: Relative Humidity.

1) Available in December 2014. 2) Referred to the nominal air flow after filter and plate heat exchanger. 3) Referred to 1.5 meters from inlet in free field condition.

Optional

<b>Internet Control Ready</b> INTERNET CONTROL	<b>Energy saving</b> INVERTER+	<b>Environmentally friendly refrigerant</b> R410A	<b>Easy maintenance</b> SELF-DIAGNOSING	<b>For more comfort</b> AUTOMATIC FAN	<b>Perfect humidity control</b> MILD DRY	<b>Further comfort</b> AUTO-FLAP CONTROL	<b>Practical operation</b> AUTOMATIC RESTART	<b>Comfort everywhere</b> AIR SWEEP	<b>Easy control by BMS</b> CONNECTIVITY
---	-----------------------------------	--	--	--	---	---	---	--	--

T2 TYPE  
CEILING



S-36MT2E5A // S-45MT2E5A // S-56MT2E5A



S-106MT2E5A // S-140MT2E5A

The T2 TYPE ceiling mounted units feature a DC fan motor for increased efficiency and reduced operating sound levels. All the units are the same height and depth for a uniform appearance in mixed installations and feature a fresh air knockout for improved air quality.

**Technical focus**

- Low sound levels
- New design, all units just 235mm high
- Large and wide air distribution
- Easy to install and maintain
- Fresh air knockout

**Further comfort improvement**

The wide air discharge opening widens the air flow to the left and the right, so that a comfortable temperature is obtained in the entire room. The unpleasant feeling caused when the air flow directly hits the human body is prevented by the "Draft prevention position", which changes the swing width, so that the degree of comfort is increased.

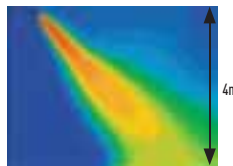

**Further comfort improvement with airflow distribution**

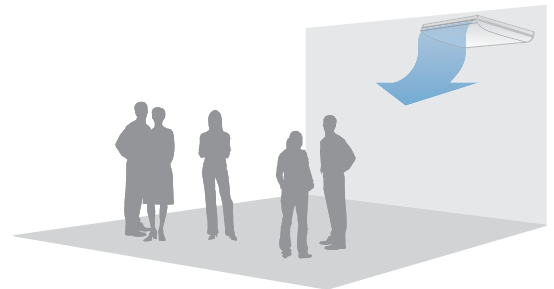

**Air distribution is automatically altered depending on the operational mode of the unit**

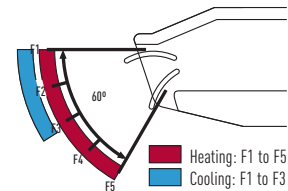

**Optional Controller**  
Wired remote controller  
CZ-RTC3



**Optional Controller**  
Timer remote controller  
CZ-RTC2



**Optional Controller**  
Wireless remote controller  
CZ-RWSK2 + CZ-RWST3



**Optional Controller**  
Simplified remote controller  
CZ-RE2C2

Model <sup>1)</sup>		S-36MT2E5A	S-45MT2E5A	S-56MT2E5A	S-73MT2E5A	S-106MT2E5A	S-140MT2E5A
Power source		230 V / Single Phase / 50 Hz					
Cooling capacity	kW	3,6	4,5	5,6	7,3	10,6	14,0
Power input cooling	W	35	40	40	55	80	100
Operating current cooling	A	0,36	0,38	0,38	0,44	0,67	0,79
Heating capacity	kW	4,2	5,0	6,3	8,0	11,4	16,0
Power input heating	W	35	40	40	55	80	100
Operating current heating	A	0,36	0,38	0,38	0,44	0,67	0,79
Fan type		Sirocco fan					
Air volume	Hi / Med / Lo m <sup>3</sup> /h	840 / 720 / 630	900 / 750 / 630	900 / 750 / 630	1.260 / 1.080 / 930	1.800 / 1.500 / 1.380	1.920 / 1.680 / 1.440
Sound pressure level	L <sub>p</sub> <sup>2</sup> / Lo / Med / Hi dB(A)	30 / 32 / 36	30 / 33 / 37	30 / 33 / 37	33 / 35 / 39	36 / 37 / 42	37 / 40 / 46
Dimensions	H x W x D mm	235 x 960 x 690	235 x 960 x 690	235 x 960 x 690	235 x 1.275 x 690	235 x 1.590 x 690	235 x 1.590 x 690
Pipe connections	Liquid	inch (mm)	1/4 (6,35)	1/4 (6,35)	1/4 (6,35)	3/8 (9,52)	3/8 (9,52)
	Gas	inch (mm)	1/2 (12,7)	1/2 (12,7)	1/2 (12,7)	5/8 (15,88)	5/8 (15,88)
	Drain piping		VP-20	VP-20	VP-20	VP-20	VP-20
Net weight	kg	27	27	27	33	40	40

Rating Conditions: Cooling Indoor 27°C DB / 19°C WB. Cooling Outdoor 35°C DB / 24°C WB. Heating Indoor 20°C DB. Heating Outdoor 7°C DB / 6°C WB. DB: Dry Bulb; WB: Wet Bulb.

1) Available from May 2014.  
2) Sound pressure level with fan only.  
\* Preliminary data.

Optional

<b>Internet Control Ready</b>	<b>Energy saving</b>	<b>Environmentally friendly refrigerant</b>	<b>Easy maintenance</b>	<b>For more comfort</b>	<b>Perfect humidity control</b>	<b>Further comfort</b>	<b>Practical operation</b>	<b>Comfort everywhere</b>	<b>Easy control by BMS</b>
INTERNET CONTROL	INVERTER+	R410A	SELF-DIAGNOSING	AUTOMATIC FAN	MILD DRY	AUTO-FLAP CONTROL	AUTOMATIC RESTART	AIR SWEEP	CONNECTIVITY



## K2/K1 TYPE WALL MOUNTED



S-15MK2E5A // S-22MK2E5A // S-28MK2E5A // S-36MK2E5A



S-45MK1E5A // S-56MK1E5A // S-73MK1E5A // S-106MK1E5A



**Optional Controller**  
Wired remote controller  
CZ-RTC3



**Optional Controller**  
Timer remote controller  
CZ-RTC2



**Optional Controller**  
Wireless remote controller  
CZ-RWSK2



**Optional Controller**  
Simplified remote controller  
CZ-RE2C2

The K2/K1 Type wall mounted unit has a stylish smooth panel which not only looks good but is also easy to clean.

The unit is also smaller, lighter and substantially quieter than previous models making it ideal for small offices and other commercial applications.

### Technical focus

- Closed discharge port
- Lighter and smaller units make the installation easy
- Quiet operation
- Smooth and durable design
- Piping outlet in three directions
- Washable front panel
- Air distribution is automatically altered depending on the operational mode of the unit

### Closed discharge port

When the unit is turned OFF, the flap closes completely to prevent entry of dust into the unit and to keep the equipment clean.

### Lighter and smaller units make the installation easy

The width has been decreased by 17% and the units are lighter.

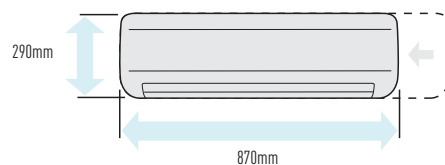

### Quiet operation

These units are among the quietest in the industry, making them ideal for hotels and hospitals.

### Smooth and durable design

The smooth cover means these units match most modern interiors. Their compact size enables them to blend in, even in small spaces.

### Piping outlet in three directions

Piping outlet is possible in the three directions of rear, right, and left, making the installation work easier.

### Washable front panel

The indoor unit's front panel can be easily removed and washed for trouble-free cleaning.

### Air distribution is automatically altered depending on the operational mode of the unit

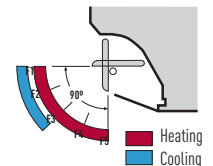

### External valve (Optional)

CZ-P56SVK2 (model sizes 15 to 56)  
CZ-P160SVK2 (model sizes 73 to 106)



Model <sup>1</sup>		S-15MK2E5A	S-22MK2E5A	S-28MK2E5	S-36MK2E5	S-45MK1E5A	S-56MK1E5A	S-73MK1E5A	S-106MK1E5A	
Power source						230 V / Single Phase / 50 Hz				
Cooling capacity	kW	1,5	2,2	2,8	3,6	4,5	5,6	7,3	10,6	
Power input cooling	W	25	25	25	30	20	30	57	60	
Operating current cooling	A	0,20	0,21	0,23	0,25	0,26	0,35	0,58	0,62	
Heating capacity	kW	1,7	2,5	3,2	4,2	5,0	6,3	8,0	11,4	
Power input heating	W	25	25	25	30	20	30	57	68	
Operating current heating	A	0,20	0,21	0,23	0,25	0,26	0,35	0,58	0,70	
Fan type		Cross flow	Cross flow	Cross flow	Cross flow	Cross flow	Cross flow	Cross flow	Cross flow	
Air volume	Hi / Med / Lo	m <sup>3</sup> /h	474 / 444 / 390	540/450/390	570/498/390	654/540/390	720 / 630 / 510	840 / 720 / 630	1.080 / 870 / 690	1.140 / 990 / 780
		m <sup>3</sup> /h	540 / 462 / 408	552/498/408	582/510/408	672/570/408				
Sound pressure level	L <sub>1</sub> <sup>2</sup> / Lo / Med / Hi	dB(A)	— / 29 / 32 / 34	— / 29 / 33 / 36	— / 29 / 34 / 37	— / 29 / 36 / 40	— / 32 / 36 / 40	— / 40 / 44 / 47	— / 42 / 45 / 49	
Dimensions	H x W x D	mm	290 x 870 x 214	290 x 870 x 214	290 x 870 x 214	290 x 870 x 214	300 x 1.065 x 230	300 x 1.065 x 230	300 x 1.065 x 230	300 x 1.065 x 230
Pipe connections	Liquid	inch (mm)	1/4 (6,35)	1/4 (6,35)	1/4 (6,35)	1/4 (6,35)	1/4 (6,35)	3/8 (9,52)	3/8 (9,52)	
	Gas	inch (mm)	1/2 (12,7)	1/2 (12,7)	1/2 (12,7)	1/2 (12,7)	1/2 (12,7)	5/8 (15,88)	5/8 (15,88)	
	Drain piping (O.D.)	φ	φ 16	φ 16	φ 16	φ 16	φ 18	φ 18	φ 18	
Net weight	kg	9	9	9	9	13	13	14,5	14,5	

Rating Conditions: Cooling Indoor 27°C DB / 19°C WB. Cooling Outdoor 35°C DB / 24°C WB. Heating Indoor 20°C DB. Heating Outdoor 7°C DB / 6°C WB.  
DB: Dry Bulb; WB: Wet Bulb.

1) Available from April 2014.  
2) Sound pressure level with fan only.

### Optional

<b>Internet Control Ready</b> INTERNET CONTROL	<b>Energy saving</b> INVERTER+	<b>Environmentally friendly refrigerant</b> R410A	<b>Easy maintenance</b> SELF-DIAGNOSING	<b>For more comfort</b> AUTOMATIC FAN	<b>Perfect humidity control</b> MILD DRY	<b>Further comfort</b> AUTO-FLAP CONTROL	<b>Practical operation</b> AUTOMATIC RESTART	<b>Comfort everywhere</b> AIR SWEEP	<b>Easy control by BMS</b> CONNECTIVITY
---	-----------------------------------	--	--	--	---	---	---	--	--

# P1 TYPE FLOOR STANDING



The compact floor standing P1 units are the ideal solution for providing perimeter air conditioning. The standard wired controller can be incorporated into the body of the unit.

A standard wired remote control can be installed in the body

### Technical focus

- Pipes can be connected to either side of the unit from the bottom or rear
- Easy to install
- Front panel opens fully for easy maintenance
- Removable air discharge grille gives flexible air flow
- Room for condensate pump



### Effective perimeter handling

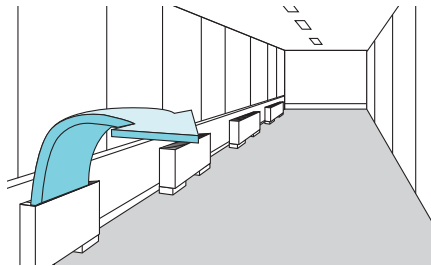

**Optional Controller**  
Wired remote controller  
CZ-RTC3



**Optional Controller**  
Timer remote controller  
CZ-RTC2



**Optional Controller**  
Wireless remote controller  
CZ-RWSC2 + CZ-RWSC3



**Optional Controller**  
Simplified remote controller  
CZ-RE2C2

Model		S-22MP1E5	S-28MP1E5	S-36MP1E5	S-45MP1E5	S-56MP1E5	S-71MP1E5
Power source		230 V / Single Phase / 50 Hz					
Cooling capacity	kW	2,2	2,8	3,6	4,5	5,6	7,1
Power input cooling	W	56	56	85	126	126	160
Operating current cooling	A	0,25	0,25	0,38	0,56	0,56	0,72
Heating capacity	kW	2,5	3,2	4,2	5,0	6,3	8,0
Power input heating	W	40	40	70	91	91	120
Operating current heating	A	0,18	0,18	0,31	0,41	0,41	0,54
Fan type		Sirocco fan	Sirocco fan	Sirocco fan	Sirocco fan	Sirocco fan	Sirocco fan
Air volume	Hi / Med / Lo	m <sup>3</sup> /h	420 / 360 / 300	420 / 360 / 300	540 / 420 / 360	720 / 540 / 480	900 / 780 / 660
Sound pressure level	Lo / Med / Hi	dB(A)	28 / 30 / 33	28 / 30 / 33	29 / 35 / 39	31 / 35 / 38	31 / 36 / 39
Dimensions	H x W x D	mm	615 x 1.065 x 230	615 x 1.065 x 230	615 x 1.065 x 230	615 x 1.380 x 230	615 x 1.380 x 230
Net weight		kg	29	29	29	39	39
Pipe connections	Liquid	inch (mm)	1/4 (6,35)	1/4 (6,35)	1/4 (6,35)	1/4 (6,35)	3/8 (9,52)
	Gas	inch (mm)	1/2 (12,7)	1/2 (12,7)	1/2 (12,7)	1/2 (12,7)	5/8 (15,88)
Drain piping			VP-20	VP-20	VP-20	VP-20	VP-20

Rating Conditions: Cooling Indoor 27°C DB / 19°C WB. Cooling Outdoor 35°C DB / 24°C WB. Heating Indoor 20°C DB. Heating Outdoor 7°C DB / 6°C WB.  
DB: Dry Bulb; WB: Wet Bulb.

Optional

<b>Internet Control Ready</b> INTERNET CONTROL	<b>Energy saving</b> INVERTER+	<b>Environmentally friendly refrigerant</b> R410A	<b>Easy maintenance</b> SELF-DIAGNOSING	<b>For more comfort</b> AUTOMATIC FAN	<b>Perfect humidity control</b> MILD DRY	<b>Practical operation</b> AUTOMATIC RESTART	<b>Easy control by BMS</b> CONNECTIVITY
---	-----------------------------------	--	--	--	---	---	--

# R1 TYPE CONCEALED FLOOR STANDING



At just 229mm deep, the R1 unit can be easily concealed in perimeter areas to provide powerful and effective air conditioning.

### Technical focus

- Chassis unit for discreet installation
- Complete with removable filters
- Pipes can be connected to either side of the unit from the bottom or rear
- Easy to install

### Perimeter air conditioning with high interior quality

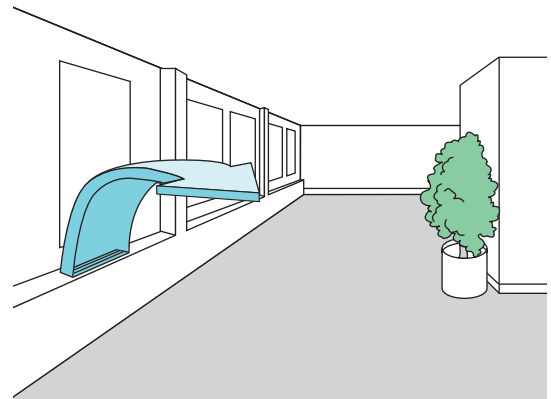

**Optional Controller**  
Wired remote controller  
CZ-RTC3



**Optional Controller**  
Timer remote controller  
CZ-RTC2



**Optional Controller**  
Wireless remote controller  
CZ-RWSK2 + CZ-RWSC3



**Optional Controller**  
Simplified remote controller  
CZ-RE2C2







Model	S-22MR1E5		S-28MR1E5		S-36MR1E5		S-45MR1E5		S-56MR1E5		S-71MR1E5	
Power source	230 V / Single Phase / 50 Hz											
Cooling capacity	kW	2,2	2,8	3,6	4,5	5,6	7,1					
Power input cooling	W	56	56	85	126	126	160					
Operating current cooling	A	0,25	0,25	0,38	0,56	0,56	0,72					
Heating capacity	kW	2,5	3,2	4,2	5,0	6,3	8,0					
Power input heating	W	40	40	70	91	91	120					
Operating current heating	A	0,18	0,18	0,31	0,41	0,41	0,54					
Fan type	Sirocco fan											
Air volume	Hi / Med / Lo	m <sup>3</sup> /h	420 / 360 / 300	420 / 360 / 300	540 / 420 / 360	720 / 540 / 480	900 / 780 / 660	1.020 / 840 / 720				
Sound pressure level	Lo / Med / Hi	dB(A)	28 / 30 / 33	28 / 30 / 33	29 / 35 / 39	31 / 35 / 38	31 / 36 / 39	35 / 38 / 41				
Dimensions	H x W x D	mm	616 x 904 x 229	616 x 904 x 229	616 x 904 x 229	616 x 1.219 x 229	616 x 1.219 x 229	616 x 1.219 x 229				
Net weight	kg		21	21	21	28	28	28				
Pipe connections	Liquid	inch (mm)	1/4 (6,35)	1/4 (6,35)	1/4 (6,35)	1/4 (6,35)	1/4 (6,35)	1/4 (6,35)	3/8 (9,52)			
	Gas	inch (mm)	1/2 (12,7)	1/2 (12,7)	1/2 (12,7)	1/2 (12,7)	1/2 (12,7)	5/8 (15,88)				
Drain piping			VP-20	VP-20	VP-20	VP-20	VP-20	VP-20				

Rating Conditions: Cooling Indoor 27°C DB / 19°C WB. Cooling Outdoor 35°C DB / 24°C WB. Heating Indoor 20°C DB. Heating Outdoor 7°C DB / 6°C WB.  
DB: Dry Bulb; WB: Wet Bulb.

Optional

<b>Internet Control Ready</b> INTERNET CONTROL	<b>Energy saving</b> INVERTER+	<b>Environmentally friendly refrigerant</b> R410A	<b>Easy maintenance</b> SELF-DIAGNOSING	<b>For more comfort</b> AUTOMATIC FAN	<b>Perfect humidity control</b> MILD DRY	<b>Practical operation</b> AUTOMATIC RESTART	<b>Easy control by BMS</b> CONNECTIVITY
---	-----------------------------------	--	--	--	---	---	--













Operation System	Individual Control Systems					
Requirements	Control for hotel application (for VRF)		Wired remote controller		Wireless remote controller	Quick and easy operation
External appearance						 
Type, model name	Intelligent Controller		Normal operation	Design wired remote controller	Wireless remote controller	Simplified remote controller      Backlit remote controller
	PAW-RE2C3-WH PAW-RE2C3-GR PAW-RE2C3-MOD-WH PAW-RE2C3-MOD-GR PAW-RE2C3-LON-WH PAW-RE2C3-LON-GR	Stand-Alone White Stand-Alone Grey Modbus White Modbus Grey LonWorks White LonWorks Grey	CZ-RTC2	CZ-RTC3 	CZ-RWSU2 // CZ-RWSY2 // CZ-RWSL2 // CZ-RWSC3 // CZ-RWST2 // CZ-RWST3 // CZ-RWSK2	CZ-RE2C2      CZ-RELC2
Econavi Control	—			✓	—	—
Power consumption monitor	—			✓ <sup>2</sup>	—	—
Built-in Thermostat	✓			✓	✓	✓
I/O which can be controlled	1 indoor unit			1 group, 8 units	1 group, 8 units	1 group, 8 units
Use limitations	—			• Up to 2 controllers can be connected per group	• Up to 2 controllers can be connected per group	• CZ-RE2C2: up to 2 controllers can be connected per group • CZ-RELC2: can not operate other (SUB) remo-con
Function ON/OFF	✓			✓	✓	✓
Mode setting	AUTO			✓	✓	✓
Fan speed setting	✓			✓	✓	✓
Temperature setting	✓			✓	✓	✓
Air flow direction	—			✓	✓ <sup>1</sup>	✓ <sup>1</sup>
Permit/Prohibit switching	✓			—	—	—
Weekly program	—			✓	—	—

1. Setting is not possible when a remote control unit is present (use the remote control for setting). 2) Only for PACi Elite except 50 type. \* All specifications subject to change without notice.

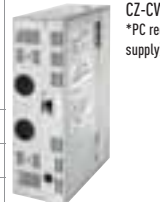

## Control systems for ECO G

A wide variety of control options to meet the requirements of different applications.

Timer Operation	Centralized Control Systems					
Daily and weekly program	Operation with various function from center station	Only ON/OFF operation from center station	Simplified load distribution ratio (LDR) for each tenant	BMS System. PC Base	Connection with 3rd Party Controller	
				<b>P-AIMS. Basic Software</b> 	<b>Seri-Para I/O unit for outdoor unit</b> CZ-CAPDC2 	
Schedule timer	System controller	ON/OFF Controller	Intelligent Controller (Touch screen panel)	<b>CZ-CSWKC2</b>		
CZ-ESWC2	CZ-64ESMC2	CZ-ANC2	CZ-256ESMC2 (CZ-CFUNC2)	<b>Optional software</b>  CZ-CSWAC2 for Load distribution. CZ-CSWWC2 for Web application. CZ-CSWGC2 for Object layout display. CZ-CSWBC2 for BAC net software interface. *PC required (field supply)	<b>Local adaptor for ON/OFF control</b> CZ-CAPC2 	
—	—	—	—		<b>MINI Seri-Para I/O Unit</b> CZ-CAPBC2 	
—	—	—	—			
64 groups, maximum 64 units	64 groups, maximum 64 units	16 groups, maximum 64 units	64 units x 4 systems, max. 256 units	<b>Web Interface Systems</b>  CZ-CWEBC2 *PC required (field supply)	<b>Communication Adaptor</b> CZ-CFUNC2 	
<ul style="list-style-type: none"> <li>Required power supply from the system controller</li> <li>When there is no system controller, connection is possible to the T10 terminal of an indoor unit</li> </ul>	<ul style="list-style-type: none"> <li>Up to 10 controllers, can be connected to one system</li> <li>Main unit/sub unit (1 main unit + 1 sub unit) connection is possible</li> <li>Use without remote controller is possible</li> </ul>	<ul style="list-style-type: none"> <li>Up to 8 controllers (4 main units + 4 sub units) can be connected to one system</li> <li>Use without remote controller is impossible</li> </ul>	<ul style="list-style-type: none"> <li>A communication adaptor (CZ-CFUNC2) must be installed for three or more systems</li> </ul>			
—	✓	✓	✓			
—	✓	—	✓			
—	✓	—	✓			
—	✓	—	✓			
—	✓ <sup>1</sup>	—	✓ <sup>1</sup>			
—	✓	✓	✓			
✓	—	—	✓			

## GHP Connectivity. New Plug and play interface connected directly to the P-Link



Great flexibility for integration into your KNX / EnOcean / Modbus / LonWorks / BACnet projects allows fully bi-directional monitoring and control of all the functioning parameters. Panasonic Partners have designed solutions specifically for Panasonic air conditioners, and provide complete monitoring, control and full functionality of the entire Commercial line-up from KNX / EnOcean / Modbus / LonWorks / BACnet installations.

For more information, contact Panasonic.

Easy control by BMS  
CONNECTIVITY

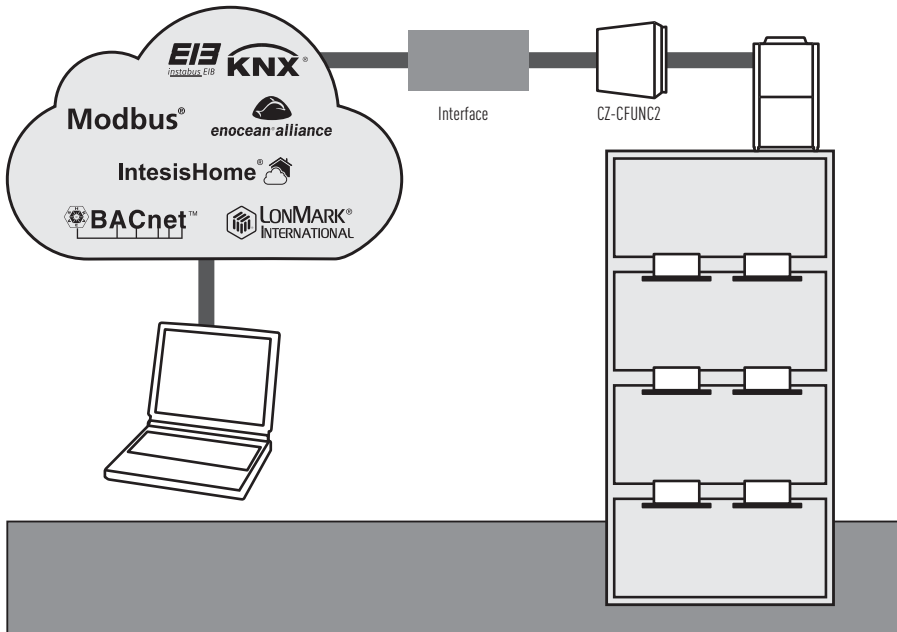

### Communication adaptor (CZ-CFUNC2)

This communication interface is required to connect a ECOi and GHP systems to a BMS. An additional interface is needed to convert the information into KNX/Modbus/Bacnet language. CZ-CFUNC2 is very easy to operate and to connect to the Panasonic P-link, which is the ECOi bus. From the CZ-CFUNC2, all the indoor and outdoor units of the installation can be easily control. Two linked wiring systems can be connected to one CZ-CFUNC2.

Dimensions: H 260 x W 200 x D 68mm

\* As this is not a splash-proof design, it must be installed indoors or in the control panel, etc.

	Panasonic Model name	Interface	Connected on P-link or in the indoor unit	Maximum number of indoor units connected
ECOi / PACi Indoor Units	PAW-RC2-KNX-1i	KNX	Indoor unit	1 (1 Group of Indoor units)
	PAW-RC2-MBS-1	Modbus RTU*	Indoor unit	1 (1 Group of Indoor units)
	PAW-RC2-ENO-1i	EnOcean	Indoor unit	1 (1 Group of Indoor units)
	PA-RC2-WIFI-1	IntesisHome	Indoor unit	1 (1 Group of Indoor units)
ECOi P-Link	PAW-AC-KNX-64	KNX**	P-link	64
	PAW-AC-KNX-128	KNX**	P-link	128
	PAW-TM-MBS-RTU-64	Modbus RTU**	P-link	64
	PAW-TM-MBS-TCP-128	Modbus TCP**	P-link	128
	PAW-AC-BAC-64	Bacnet**	P-link	64
	PAW-AC-BAC-128	Bacnet**	P-link	128
	CZ-CLNC2	Lonworks	P-link	16 groupes of max. 8 indoor units, in total max. 64 indoor units

\* Interface Modbus RTU/TCP is needed in case if Modbus TCP connection. PAW-MBS-TCP2RTU (Modbus RTU Slave devices).

\*\* Interface CZ-CFUNC2 needed.

Example of BMS connection for air conditioner central control system

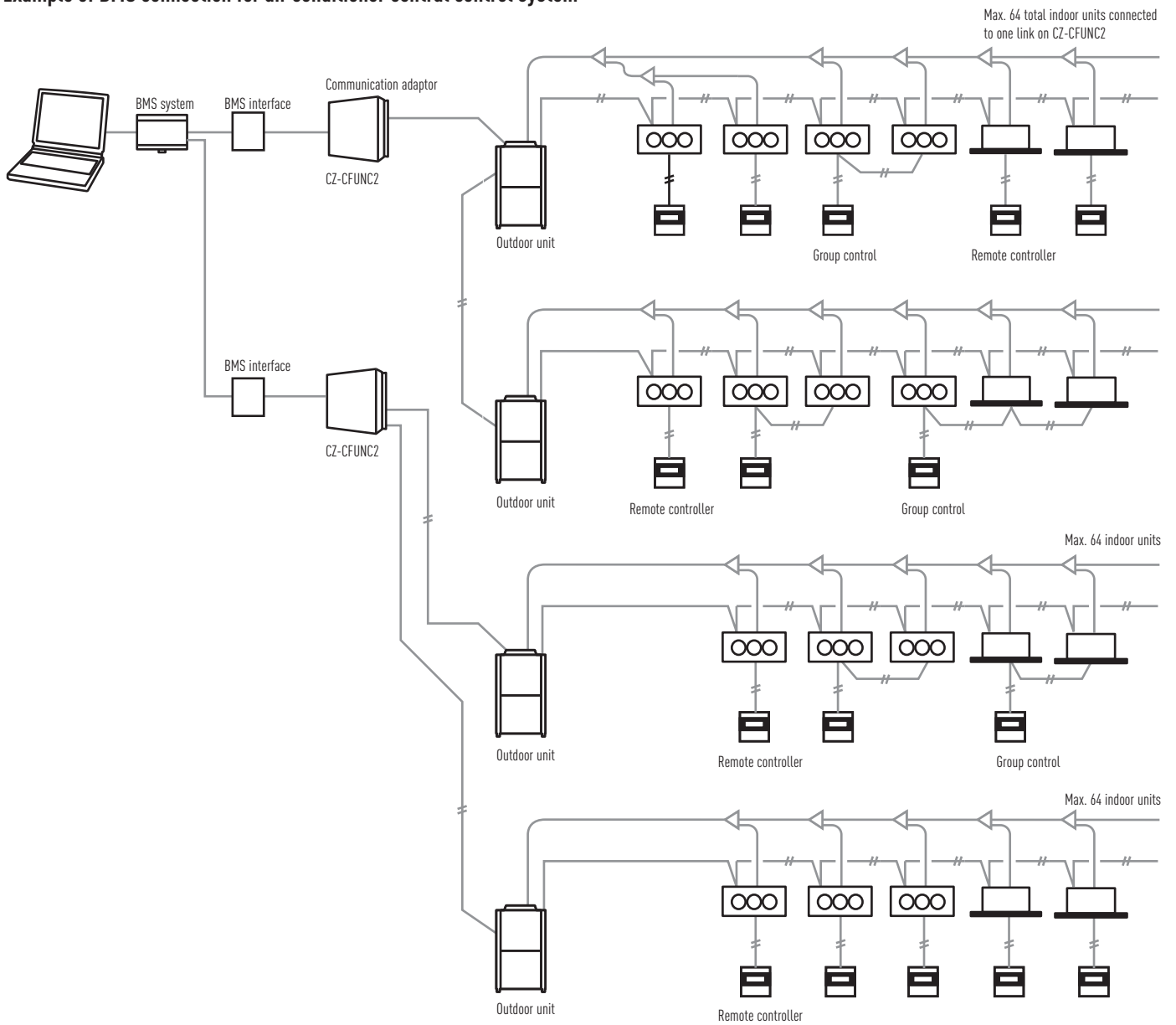

	Unit ON/OFF
A/C unit settings	Mode-change
	Room temperature setting
	Fan speed setting
	Flap setting
	Central control setting
	Filter-sign clear
	Alarm reset

	Unit ON/OFF status
A/C unit status	Operation mode
	Setting temperature
	Fan speed status
	Flap status
	Central control setting
	Filter-sign situation
	Correct/incorrect status
	Alarm code

Due to the ongoing innovation of our products, the specifications of this catalogue are valid barring typographic errors, and may be subject to minor modifications by the manufacturer without prior warning in order to improve the product. The total or partial reproduction of this catalogue is prohibited without the express authorisation of Panasonic UK Ltd.

# Panasonic®

To find out how Panasonic cares for you,  
log on to: [www.aircon.panasonic.eu](http://www.aircon.panasonic.eu)



Do not add or replace refrigerant other than the specified type. Manufacturer is not responsible for the damage and deterioration in safety due to usage of the other refrigerant.

Panasonic Marketing Europe GmbH  
Panasonic Air Conditioning  
Hagenauer Strasse 43, 65203 Wiesbaden, Germany

