

1702-2V1609



VRF 50Hz V4+K/V4+S/V4+R/V4+W/V4+I/Mini VRF

# Commercial Air Conditioners 2017



## VRF 50Hz V4+K/V4+S/V4+R/V4+W/V4+I/Mini VRF

### Commercial Air Conditioner Division Midea Group

Add.: Midea Headquarters Building, 6 Midea Avenue, Shunde, Foshan, Guangdong, China

Postal code: 528311

Tel: +86-757-26338346 Fax: +86-757-22390205

[cac.midea.com](http://cac.midea.com) [global.midea.com](http://global.midea.com)

Note: Product specifications change from time to time as product improvements and developments are released and may vary from those in this document.



Midea CAC After-service Application

Midea CAC News Application



iOS Version

Android Version

iOS Version



# Midea CAC

Midea CAC is a key division of the Midea Group, a leading producer of consumer appliances and provider of heating, ventilation and air conditioning solutions. Midea CAC has continued with the tradition of innovation upon which it was founded, and emerged as a global leader in the HVAC industry. A strong drive for advancement has created a groundbreaking R&D department that has placed Midea CAC at the forefront of a competitive field. Through these independent efforts and joint cooperation with other global enterprises, Midea has supplied thousands of innovative solutions to customers worldwide.

There are three production bases: Shunde, Chongqing and Hefei.

MCAC Shunde: 38 product lines focusing on VRF, Split Products, Heat Pump Water Heaters, and AHU/FCU.

MCAC Chongqing: 14 product lines focusing on Water Cooled Centrifugal/Screw/Scroll Chillers, Air Cooled Screw/Scroll Chillers, and AHU/FCU.

MCAC Hefei: 11 product lines focusing on VRF, Chillers, and Heat Pump Water Heaters.



**Midea Company  
Introduction**



**Midea CAC  
Introduction**



2014-2015 >> Win FIFA World Cup Stadiums project in Brazil Beira Rio, Olympic Games Stadiums project in Brazil Rio de Janeiro and Africa games Stadiums project in Congo Brazzaville successively

2014 >> Launched the All DC Inverter V5X globally, outstanding product performance helps Midea leading VRF market

2011-2014 >> Launched the DC Inverter V4 Plus Series successively, complete product lines help Midea successfully enter the mainstream VRF market

2011-2012 >> J.V. with Carrier LA and Carrier India successively

2009 >> Launched the DC Inverter V4 globally

2008 >> Developed DC inverter technology with Toshiba

2000-2001 >> Cooperated with Toshiba and Copeland, enter VRF field

1999 >> Entered the CAC field



# INDEX



## OUTDOOR UNITS

- 21 VRF V4 Plus K Series
- 27 VRF V4 Plus S Series
- 33 VRF V4 Plus R Series
- 41 VRF V4 Plus W Series
- 45 VRF V4 Plus I Series
- 49 VRF Mini Series



## INDOOR UNITS

- 56 One-way Cassette
- 57 Two-way Cassette
- 58 Four-way Cassette
- 63 Low Static Pressure Duct
- 64 Medium Static Pressure Duct (A5 Type)
- 65 High Static Pressure Duct
- 67 Fresh Air Processing Unit
- 68 Console
- 69 Wall-mounted
- 71 Ceiling & Floor
- 73 Floor Standing



## CONTROL SYSTEMS

- 77 Wireless Remote Controller
- 79 Wired Controller
- 87 Centralized Controller & Monitor
- 95 Network control Software & Gateways
- 111 Accessories



## HRV

- 120 Heat Recovery Ventilator

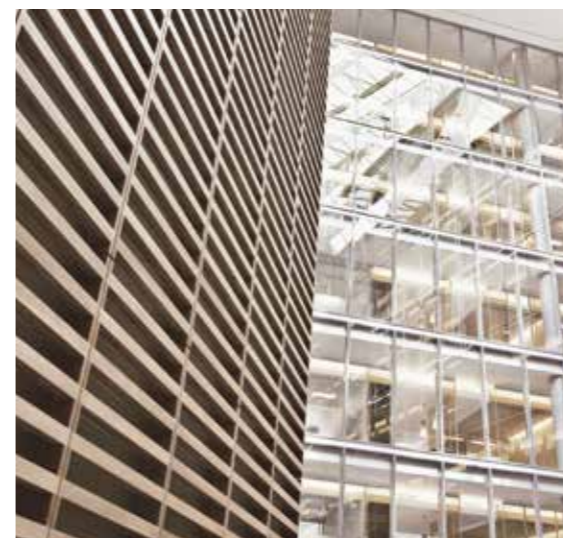

## BRANCH PIPE

- 123 Branch Pipe

# VRF SYSTEM



## VRF V4 Plus **K**ing Series



Heat pump/Cooling only  
 Max. 4 modules can be combined  
 8~72HP  
 DC inverter compressor + fixed compressors  
 Heat pump series: All DC fan motors  
 Cooling only series: DC fan motor + AC fan motor

## VRF V4 Plus **W**ater Cooled Series



Water cooled  
 Max. 3 modules can be combined  
 8~36HP  
 DC inverter compressor

## VRF V4 Plus **S**uper Series



Heat pump  
 Max. 4 modules can be combined  
 8~72HP  
 All DC inverter compressors  
 All DC fan motors

## VRF V4 Plus **I**ndividual Series



Heat pump, cannot be combined  
 7~32HP  
 DC inverter compressor + fixed compressors  
 DC fan motor + AC fan motor

## VRF V4 Plus Heat **R**ecovery Series



Heat recovery  
 Simultaneous cooling and heating operation in one system  
 Max. 4 modules can be combined  
 8~64HP  
 All DC inverter compressors  
 All DC fan motors

## VRF V4 Plus **M**ini Series







Heat pump, cannot be combined  
 3~6.5HP  
 DC inverter compressor  
 All DC fan motors





# OUTDOOR UNIT LINEUP

## Connectable VRF

HP	8	10	12	14	16	18	20	22	24	26	28	30	32	34	36	38	40	42	44	46	48	50	52	54	56	58	60	62	64	66	68	70	72
VRF V4 PLUS K SERIES																																	
VRF V4 PLUS S SERIES																																	
VRF V4 PLUS R SERIES																																	
VRF V4 PLUS W SERIES																																	

## Single VRF

HP	3	4	4.5	5	6	6.5	7	8	10	12	14	16	20	22	24	26	28	30	32					
VRF MINI SERIES																								
VRF V4 PLUS I SERIES																								

■ Single unit  
■ Multi combination

# INDOOR UNIT LINEUP

kW		1.5	1.8	2.2	2.8	3.6	4.5	5.6	7.1	8.0	9.0	10.0	11.2	12.5	14.0	16.0	20.0	25.0	28.0	40.0	45.0	56.0				
Btu/h		5k	6k	7k	9k	12k	15k	19k	24k	27k	30k	34k	38k	42k	48k	55k	68k	85k	96k	136k	154k	191k				
Cassette	One-way cassette		Available																							
	Two-way cassette			Available																						
	Four-way cassette				Available																					
	Compact four-way cassette	Available		Available																						
Duct	Low static pressure		Available																							
	Medium static pressure	Available		Available																						
	High static pressure								Available																	
	Fresh air processing unit													Available			Available									
Wall mounted	Available		Available																							
Ceiling & floor					Available																					
Floor standing			Available																							
Console			Available																							

Notes:  
 1.5kW model is only available for Mini VRF and V4+I (side discharge) Series.  
 Fresh air processing unit is not available for V4+R and Mini VRF Series.



# REFERENCE PROJECTS

## Residential Place >>



**Case 1: Time City**

Country: Vietnam  
 City: Ha Noi  
 Total Capacity: 1,700 HP  
 A/C: DC Inverter VRF System  
 Completion Year: 2013  
 Total Floor Area: 260,000 m<sup>2</sup>

## Hotel >>



**Case 2: Alan Xafira Deluxe Resort & Spa (Five Star)**

Country: Turkey  
 City: Alanya  
 Total Capacity: 1,380 HP  
 A/C: DC Inverter VRF  
 Completion Year: 2013

## Sports >>



**Case 3: 2014 FIFA World Cup Brazil Beira Rio Stadium**

Country: Brazil  
 City: Porto Alegre  
 Total Capacity: 1,016 HP  
 A/C: DC Inverter VRF (Heat Recovery)  
 Completion Year: 2014

## Governmental Project >>

**Case 4: Mozambique Presidential Palace**

Country: Mozambique  
 City: Maputo  
 Total Capacity: 863 HP  
 A/C: DC Inverter VRF System  
 Completion Year: 2013







# » OUTDOOR UNITS

## VRF V4 PLUS SYSTEM

- VRF V4 PLUS K SERIES
- VRF V4 PLUS S SERIES
- VRF V4 PLUS R SERIES
- VRF V4 PLUS W SERIES
- VRF V4 PLUS I SERIES
- VRF MINI SERIES



# Technologies



## 1. High Efficiency DC Inverter Compressor >>

Midea VRF Air Conditioner achieves the industry's top class energy efficiency in cooling and heating by utilizing DC inverter compressor, DC fan motor, and high efficiency heat exchanger. The DC inverter compressor adopts innovative design and numerous high performance key parts which can reduce power consumption by 25%.

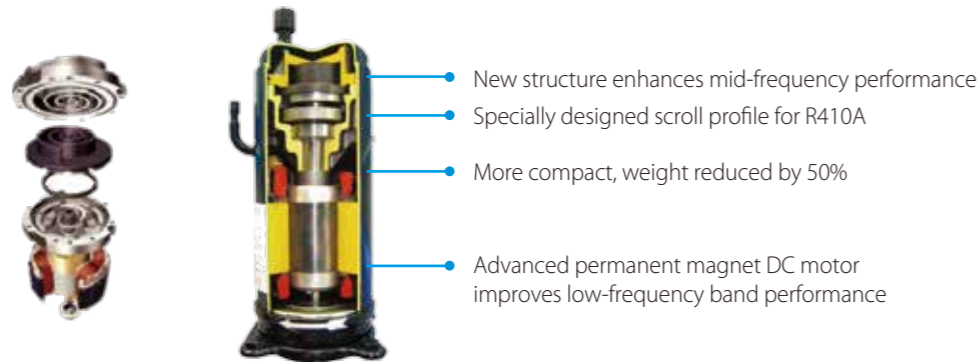

## 2. High Efficiency DC Fan Motor >>

The system controls the speed of the fan motor according to the system pressure and system load achieving the minimum power consumption.

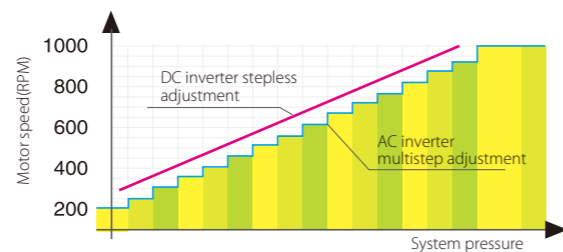

## 3. High Efficiency Heat Exchanger >>

Newly designed window type fins enlarge the heat exchange area and decrease air resistance, enhance heat exchange performance and save more energy.

Hydrophilic fins and internally threaded copper pipes optimize heat exchange efficiency.

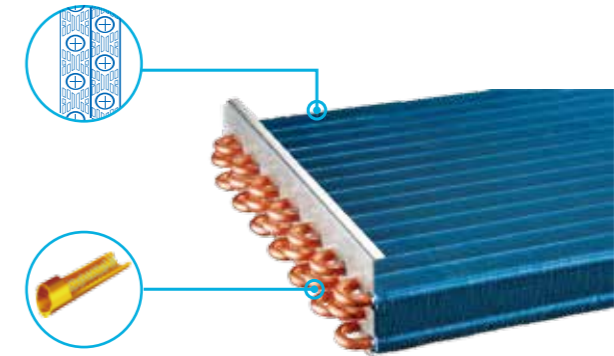

## 4. Newly Designed Fan >>

A new blade with sharp edges and a slight curve increases the airflow rate and lowers vibration and airflow resistance.

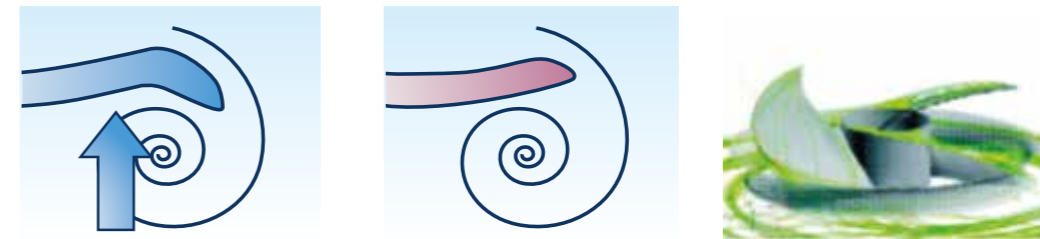

## 5. Multi Solenoid Valves Control >>

Multi solenoid valves control technology in one system. All the solenoid valves equipped in the unit ensure precise temperature control, stable and efficient running conditions and improved comfort.

## 6. Double EXVs Control >>

Double EXVs in one system, each EXV part achieves 480 Pulse rate to precisely adjust refrigerant flow.

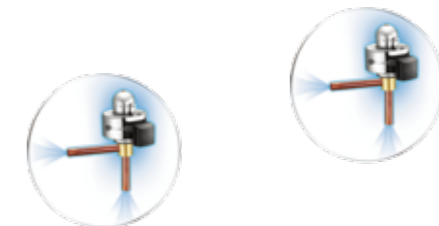

# Wide Application Range

## Wide Capacity Range >>

Midea VRF has extensive capacity ranging from 3HP to 72HP, meets all customer requirement concerning small to large buildings.



## Wide Range of Indoor Units >>

Midea provides 12 types and more than 100 models of VRF indoor units maximum meeting varied customer requirements. It widely applied in market, hospital, office building, hotel, airport, etc..



## Wide Operation Range >>

The VRF system operates stably under extreme conditions, ranging from minus 20°C to 48°C.

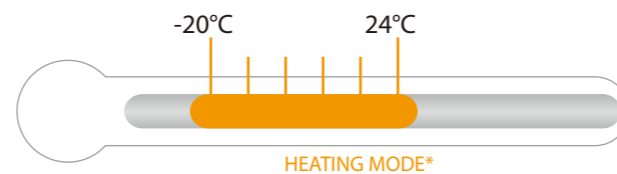
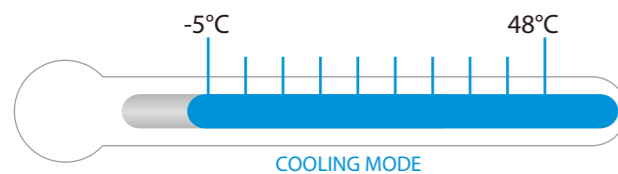

\*HEATING MODE is only available for heat pump series.

# High Reliability

## Cycle Duty Operation >>

The cyclical start-up sequence of outdoor units and DC inverter compressors equalized compressor duty and extends operating life.



## Backup Operation >>

In a multiple system, if one module is failed, other modules can be backup instead of the failed one for continuing operation.



## Precise Oil Control Technology >>

5 stages oil control technology ensures all outdoor unit and compressor oil is always kept at a safe level, completely solving any compressor oil shortage problems.

- ❖ **1st stage:** Compressor internal oil separation.
- ❖ **2nd stage:** High efficiency centrifugal oil separator (separation efficiency up to 99%) ensures oil separated from the discharge gas is returned to the compressors.
- ❖ **3rd stage:** Oil balance pipes between compressors ensure even oil distribution to keep compressors running normally.
- ❖ **4th stage:** Oil balance pipes among modules ensure even oil distribution among modules.
- ❖ **5th stage:** Auto oil return program by monitoring the running time and system status ensures reliable oil return.

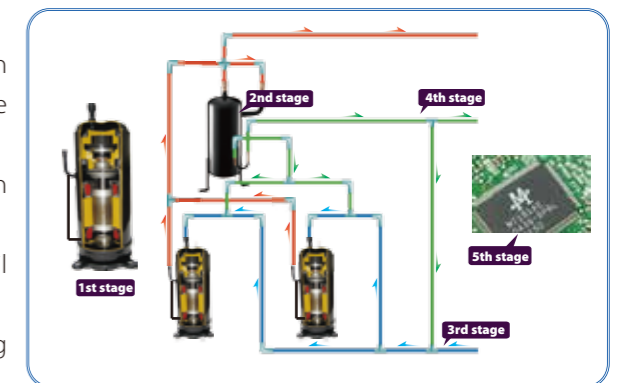



# Enhanced Comfort

## Night Silent Operation Mode >>

Night Silent Mode feature which is easily set on the PCB board allows the unit to be set to various time options during Non-peak and Peak operation time minimizing the units noise output.

Night Silent operation will be activated X hours after the peak daytime temperature, and it will go back to normal operation after Y hours.

- Mode 1→X: 6 hours, Y: 10 hours
- Mode 2→X: 8 hours, Y: 10 hours
- Mode 3→X: 6 hours, Y: 12 hours
- Mode 4→X: 8 hours, Y: 8 hours

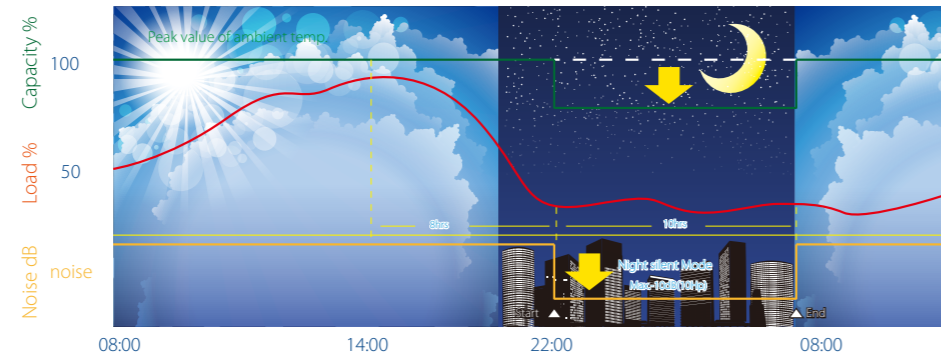

Notes: This function can be activated on site. Temperature (load) curve shown in the graph is just an example.

## Intelligent Defrosting Technology >>

Intelligent defrosting program will judge the defrosting time according to the system real requirement, reduce heating loss caused by unnecessary defrosting and create more comfort. Defrosting time can be shortened to 4 min. due to the specialized defrosting valve.

\*This function is only available for heat pump series.

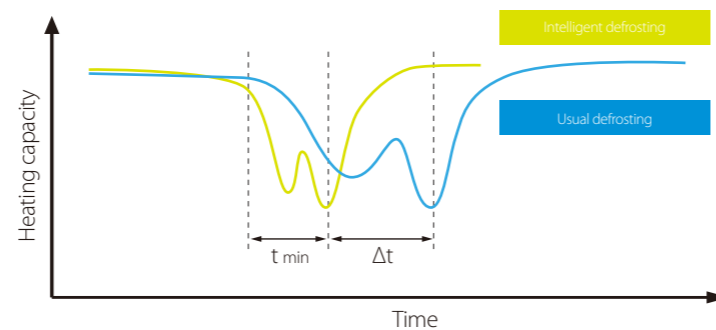

## Rapid Warm Up and Cool Down Function >>

The DC Inverter Compressor system reaches full load rapidly providing less temperature fluctuation and an improved living environment.

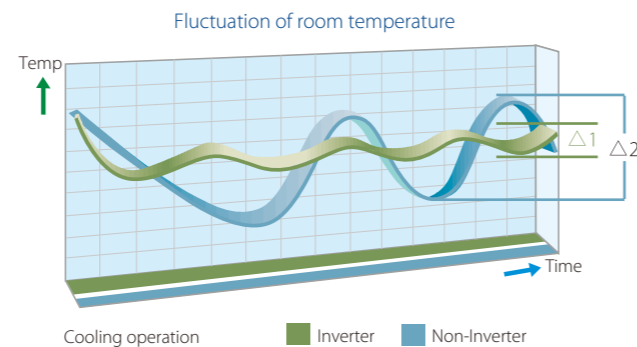

# Easy Installation and Service

## Simple Communication Wiring >>

Centralized controller (CCM03 or CCM30) can be connected from indoor side or outdoor side (XYE terminals) at will. With one set of wires, we can achieve the network communication and system communication, making installation at site more convenient.

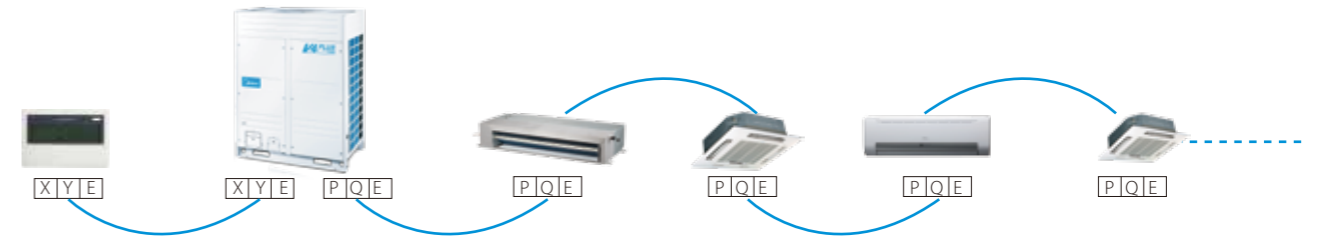

## Auto Addressing >>

Outdoor unit can distribute addresses for indoor units automatically. Wireless and wired controllers can query and modify each indoor unit's address.

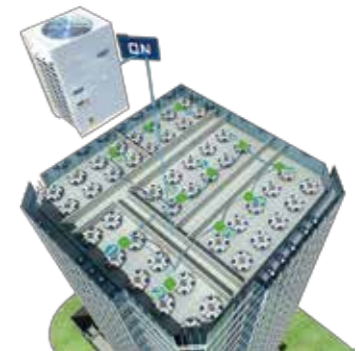

## Easy Maintenance >>

Inspection window for checking the systems status.

Self-diagnosis function helps service engineers locate faults quickly and easily.



Compressor is located near the door, which simplifies checks and enables valve or compressor parts to be replaced easily.

## Midea Unified Branch Piping >>

The unified Midea branch piping system is especially designed for simple installation and it also has specifically been designed to optimize refrigerant flow.

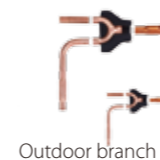

Outdoor branch joint







Indoor branch joint



Indoor branch box

\*Indoor branch box is only available for Mini VRF Series.

-  **Indoor Units**  
VRF V4 Plus indoor units
-  **Fresh Air Processing Unit**  
100% fresh air supply
-  **Ventilation**  
Heat recovery ventilator (HRV)
-  **AHU Connection Kit**  
Connect to other brand AHU
-  **Control Systems**  
Smart control systems



# VRF V4 Plus K Series Heat Pump/Cooling Only

Optimized design  
for small to large  
buildings

- » DC inverter compressor
- » DC fan motor
- » Capacity up to 72HP
- » Connectable indoor units quantity up to 64
- » ESP up to 60Pa
- » Cycle duty operation
- » Backup operation
- » Precise oil control technology
- » Advanced silence technology
- » Intelligent defrosting technology
- » Simple communication wiring
- » Auto addressing
- » Easy maintenance

## High EER and COP Values »

The cooling EER is up to 4.29 and the heating COP is up to 4.39 in the 8HP category.

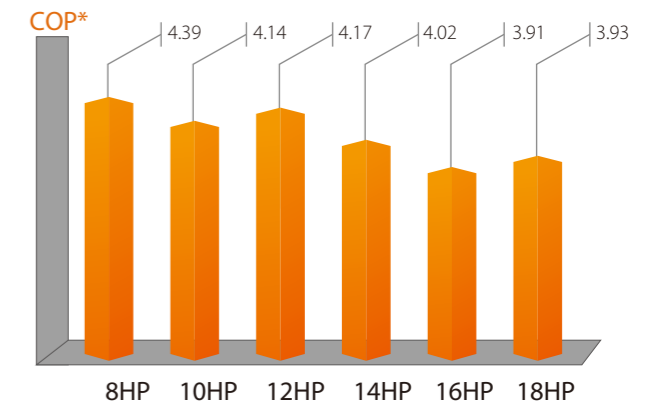
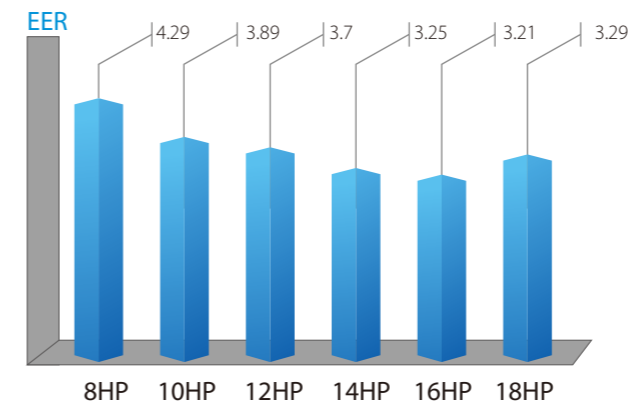

\*COP values are only available for heat pump series.

## Long Piping Length »

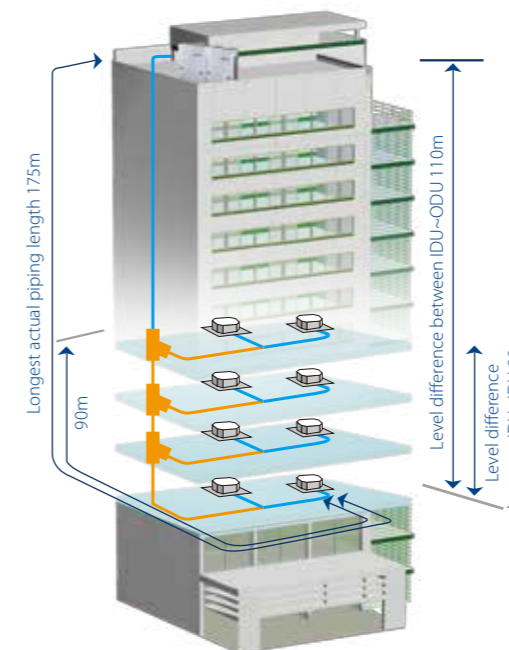

Total piping length	1000m
Longest length actual (Equivalent)	175(200)m
Longest length after first branch	90*m
Level difference between indoor and outdoor units - ODU up (down)	70(110)m
Level difference between indoor units	30m

\*The longest piping length is 40m standard. It can be extended to 90m. When the length is over 40m, please contact your local Midea dealer for more information and restrictions.



## VRF V4 Plus K Series - Heat Pump/Cooling Only



HP			8	10	12	14	16	18	
Model (Heat pump series) MDV-			252(8)W/DRN1(D)	280(10)W/DRN1(D)	335(12)W/DRN1(D)	400(14)W/DRN1(D)	450(16)W/DRN1(D)	500(18)W/DRN1(D)	
Model (Cooling only series) MDVC-			252(8)W/DRN1(C)	280(10)W/DRN1(C)	335(12)W/DRN1(C)	400(14)W/DRN1(C)	450(16)W/DRN1(C)	500(18)W/DRN1(C)	
Combined type			380-415/3/50						
Power supply	V/Ph/Hz								
Cooling	Capacity	kW	25.2	28.0	33.5	40.0	45.0	50.0	
	Power input	kW	5.88	7.20	9.05	12.31	14.02	15.20	
	EER		4.29	3.89	3.70	3.25	3.21	3.29	
Heating*	Capacity	kW	27.0	31.5	37.5	45.0	50.0	56.0	
	Power input	kW	6.15	7.61	8.99	11.19	12.79	14.25	
	COP		4.39	4.14	4.17	4.02	3.91	3.93	
Connectable indoor unit	Total capacity	50~130% of outdoor unit capacity							
	Max. quantity		13	16	20	23	26	29	
Compressor	Type	DC inverter+Fixed							
	Quantity		1	1	1+1	1+1	1+1	1+1	
Fan motor	Type	All DC motors for Heat pump series; DC+AC for Cooling only series							
	Quantity		1	1	1+1	1+1	1+1	1+1	
	Static pressure	Pa	0-20 (default)						
Refrigerant	Type	R410A							
	Factory charging	kg	9	9	11	13	13	16	
Pipe connections	Liquid pipe	mm	Φ12.7	Φ12.7	Φ15.9	Φ15.9	Φ15.9	Φ19.1	
	Gas pipe	mm	Φ25.4	Φ25.4	Φ31.8	Φ31.8	Φ31.8	Φ31.8	
	Oil balance pipe	mm	Φ6						
	Net weight (Heat pump series)	kg	200	200	268	280	280	300	
Net weight (Cooling only series)	kg	198	198	268	280	280	300		
Net weight (Cooling only series)	kg	213	213	288	300	300	320		
Operating temperature range	°C		Cooling: -5~48; Heating*: -20~24						



HP			20	22	24	26	28	
Model (Heat pump series) MDV-			560(20)W/DRN1(D)	615(22)W/DRN1(D)	680(24)W/DRN1(D)	730(26)W/DRN1(D)	780(28)W/DRN1(D)	
Model (Cooling only series) MDVC-			560(20)W/DRN1(C)	615(22)W/DRN1(C)	680(24)W/DRN1(C)	730(26)W/DRN1(C)	780(28)W/DRN1(C)	
Combined type			10HPx2				10HP+12HP	10HP+14HP
Power supply	V/Ph/Hz		380-415/3/50					
Cooling	Capacity	kW	56.0	61.5	68.0	73	78	
	Power input	kW	14.40	16.25	19.51	21.22	22.40	
	EER		3.89	3.78	3.49	3.44	3.48	
Heating*	Capacity	kW	63.0	69.0	76.5	81.5	87.5	
	Power input	kW	15.22	16.60	18.80	20.40	21.86	
	COP		4.14	4.16	4.07	4.00	4.00	
Connectable indoor unit	Total capacity	50~130% of outdoor unit capacity						
	Max. quantity		33	36	39	43	46	
Compressor	Type	DC inverter+Fixed						
	Quantity		2	2+1	2+1	2+1	2+1	
Fan motor	Type	All DC motors for Heat pump series; DC+AC for Cooling only series						
	Quantity		2	2+1	2+1	2+1	2+1	
Refrigerant	Type	R410A						
	Factory charging	kg	9x2	9+11	9+13	9+13	9+16	
Pipe connections	Liquid pipe	mm	Φ15.9	Φ15.9	Φ15.9	Φ19.1	Φ19.1	
	Gas pipe	mm	Φ28.6	Φ28.6	Φ28.6	Φ31.8	Φ31.8	
	Oil balance pipe	mm	Φ6					
	Net weight (Heat pump series)	kg	200x2	200+268	200+280	200+280	200+300	
Gross weight (Heat pump series)	kg	215x2	215+288	215+300	215+300	215+320		
Net weight (Cooling only series)	kg	198x2	198+268	198+280	198+280	198+300		
Gross weight (Cooling only series)	kg	213x2	213+288	213+300	213+300	213+320		
Operating temperature range	°C		Cooling: -5~48; Heating*: -20~24					

### Notes:

Capacities are based on the following conditions:  
 Cooling: Indoor temperature 27°C DB/19°C WB; Outdoor temperature 35°C DB/24°C WB; Heating: Indoor temperature 20°C DB/15°C WB; Outdoor temperature 7°C DB/6°C WB.  
 Piping length: Interconnecting piping length is 7.5m, level difference is zero.  
 Connection piping diameter of single-unit is the stop valve diameter of the unit.  
 Connection piping diameter of multi-unit is the main pipe connecting to the first indoor branch joint, in case of the total equivalent liquid length is less than 90m. If the total equivalent liquid length is more than 90m, please refer to technical manual to choose the connection piping diameter.  
 Sound values are measured in a semi-anechoic room, at a position 1m in front of the unit and 1.3m above the floor.  
 \*heating is only available for heat pump series.

## VRF V4 Plus K Series - Heat Pump/Cooling Only



HP			30	32	34	36	38	
Model (Heat pump series) MDV-			850(30)W/DRN1(D)	900(32)W/DRN1(D)	950(34)W/DRN1(D)	1000(36)W/DRN1(D)	1060(38)W/DRN1(D)	
Model (Cooling only series) MDVC-			850(30)W/DRN1(C)	900(32)W/DRN1(C)	950(34)W/DRN1(C)	1000(36)W/DRN1(C)	1060(38)W/DRN1(C)	
Combined type			14HP+16HP		14HP+18HP	16HP+18HP	18HPx2	
Power supply	V/Ph/Hz		380-415/3/50					
Cooling	Capacity	kW	85.0	90.0	95.0	100.0	106.0	
	Power input	kW	26.33	27.51	29.22	30.40	29.59	
	EER		3.23	3.27	3.25	3.29	3.58	
Heating*	Capacity	kW	95.0	101.0	106.0	112.0	119.0	
	Power input	kW	23.98	25.44	27.04	28.50	29.47	
	COP		3.96	3.97	3.92	3.93	4.04	
Connectable indoor unit	Total capacity	50~130% of outdoor unit capacity						
	Max. quantity		50	53	56	59	63	
Compressor	Type	DC inverter+Fixed						
	Quantity		2+2		3+1			
Fan motor	Type	All DC motors for Heat pump series; DC+AC for Cooling only series						
	Quantity		2+2		3+1			
Refrigerant	Type	R410A						
	Factory charging	kg	13+13	13+16	13+16	16x2	9x2+16	
Pipe connections	Liquid pipe	mm	Φ19.1	Φ19.1	Φ19.1	Φ19.1	Φ19.1	
	Gas pipe	mm	Φ31.8	Φ31.8	Φ38.1	Φ38.1	Φ38.1	
	Oil balance pipe	mm	Φ6					
	Net weight (Heat pump series)	kg	280x2	280+300	280+300	300x2	200x2+300	
Gross weight (Heat pump series)	kg	300x2	300+320	300+320	320x2	215x2+320		
Net weight (Cooling only series)	kg	280x2	280+300	280+300	300x2	198x2+300		
Gross weight (Cooling only series)	kg	300x2	300+320	300+320	320x2	213x2+320		
Operating temperature range	°C		Cooling: -5~48; Heating*: -20~24					



HP			40	42	44	46	48	
Model (Heat pump series) MDV-			1130(40)W/DRN1(D)	1180(42)W/DRN1(D)	1230(44)W/DRN1(D)	1280(46)W/DRN1(D)	1350(48)W/DRN1(D)	
Model (Cooling only series) MDVC-			1130(40)W/DRN1(C)	1180(42)W/DRN1(C)	1230(44)W/DRN1(C)	1280(46)W/DRN1(C)	1350(48)W/DRN1(C)	
Combined type			10HP+14HP+16HP		10HP+16HPx2	10HP+16HP+18HP	10HP+18HPx2	
Power supply	V/Ph/Hz		380-415/3/50					
Cooling	Capacity	kW	113.0	118.0	123.0	128.0	135.0	
	Power input	kW	33.53	35.24	36.42	37.59	41.53	
	EER		3.37	3.35	3.38	3.40	3.25	
Heating*	Capacity	kW	126.5	131.5	137.5	143.5	151.0	
	Power input	kW	31.59	33.18	34.65	36.11	38.23	
	COP		4.00	3.96	3.97	3.97	3.95	
Connectable indoor unit	Total capacity	50~130% of outdoor unit capacity						
	Max. quantity		64					
Compressor	Type	DC inverter+Fixed						
	Quantity		3+2		3+3			
Fan motor	Type	All DC motors for Heat pump series; DC+AC for Cooling only series						
	Quantity		3+2		3+3			
Refrigerant	Type	R410A						
	Factory charging	kg	9+13x2	9+13x2	9+13+16	9+16x2	13x2+16	
Pipe connections	Liquid pipe	mm	Φ19.1				Φ19.1	
	Gas pipe	mm	Φ38.1				Φ38.1	
	Oil balance pipe	mm	Φ6					
	Net weight (Heat pump series)	kg	11500+15100x2	11500+15100x2	11500+15100+15250	11500+15250x2	15100x2+15250	
Gross weight (Heat pump series)	kg	65					66	
Net dimension (WxHxD)	mm	(960x1615x765)+(1250x1615x765)x2					(1250x1615x765)x3	
Packing size (WxHxD)	mm	(1025x1790x830)+(1305x1790x820)x2					(1305x1790x820)x3	
Net weight (Heat pump series)	kg	200+280x2	200+280x2	200+280+300	200+300x2	280x2+300		
Gross weight (Heat pump series)	kg	215+300x2	215+300x2	215+300+320	215+320x2	300x2+320		
Net weight (Cooling only series)	kg	198+280x2	198+280x2	198+280+300	198+300x2	280x2+300		
Gross weight (Cooling only series)	kg	213+300x2	213+300x2	213+300+320	213+320x2	300x2+320		
Operating temperature range	°C		Cooling: -5~48; Heating*: -20~24					

### Notes:

Capacities are based on the following conditions:  
 Cooling: Indoor temperature 27°C DB/19°C WB; Outdoor temperature 35°C DB/24°C WB; Heating: Indoor temperature 20°C DB/15°C WB; Outdoor temperature 7°C DB/6°C WB.  
 Piping length: Interconnecting piping length is 7.5m, level difference is zero.  
 Connection piping diameter of single-unit is the stop valve diameter of the unit.  
 Connection piping diameter of multi-unit is the main pipe connecting to the first indoor branch joint, in case of the total equivalent liquid length is less than 90m. If the total equivalent liquid length is more than 90m, please refer to technical manual to choose the connection piping diameter.  
 Sound values are measured in a semi-anechoic room, at a position 1m in front of the unit and 1.3m above the floor.  
 \*heating is only available for heat pump series.

## VRF V4 Plus K Series - Heat Pump/Cooling Only



HP	50		52		54	
Model (Heat pump series) MDV-	1400(50)W/DRN1(D)		1450(52)W/DRN1(D)		1500(54)W/DRN1(D)	
Model (Cooling only series) MDVC-	1400(50)W/DRN1(C)		1450(52)W/DRN1(C)		1500(54)W/DRN1(C)	
Combined type	14HP+18HPx2		16HP+18HPx2		18HPx3	
Power supply	V/Ph/Hz		380-415/3/50		380-415/3/50	
Cooling	Capacity	kW	140.0	145.0	150.0	
	Power input	kW	42.70	44.42	45.59	
	EER		3.28	3.26	3.29	
Heating*	Capacity	kW	157.0	162.0	168.0	
	Power input	kW	39.69	41.29	42.75	
	COP		3.96	3.92	3.93	
Connectable indoor unit	Total capacity	50~130% of outdoor unit capacity				
	Max. quantity	64				
Compressor	Type	DC inverter+Fixed				
	Quantity	3+3				
Fan motor	Type	All DC motors for Heat pump series; DC+AC for Cooling only series				
	Quantity	3+3				
Refrigerant	Type	R410A				
	Factory charging	kg	13+16x2	13+16x2	16x3	
Pipe connections	Liquid pipe	mm	Φ22.2		Φ22.2	
	Gas pipe	mm	Φ41.3		Φ41.3	
	Oil balance pipe	mm	Φ6		Φ6	
Air flow rate	m <sup>3</sup> /h	15100+15250x2	15100+15250x2		15250x3	
Sound pressure level	dB(A)	66				
Net dimension (WxHxD)	mm	(1250x1615x765)x3				
Packing size (WxHxD)	mm	(1305x1790x820)x3				
Net weight (Heat pump series)	kg	280+300x2	280+300x2		300x3	
Gross weight (Heat pump series)	kg	300+320x2	300+320x2		320x3	
Net weight (Cooling only series)	kg	280+300x2	280+300x2		300x3	
Gross weight (Cooling only series)	kg	300+320x2	300+320x2		320x3	
Operating temperature range	°C	Cooling: -5-48; Heating*: -20-24				



HP	56		58		60	
Model (Heat pump series) MDV-	1560(56)W/DRN1(D)		1630(58)W/DRN1(D)		1680(60)W/DRN1(D)	
Model (Cooling only series) MDVC-	1560(56)W/DRN1(C)		1630(58)W/DRN1(C)		1680(60)W/DRN1(C)	
Combined type	10HPx2+18HPx2		10HP+14HP+16HP+18HP		10HP+14HP+18HPx2	
Power supply	V/Ph/Hz		380-415/3/50		380-415/3/50	
Cooling	Capacity	kW	156.0	163.0	168.0	
	Power input	kW	44.79	48.72	49.90	
	EER		3.48	3.35	3.37	
Heating*	Capacity	kW	175.0	182.5	188.5	
	Power input	kW	43.72	45.84	47.30	
	COP		4.00	3.98	3.98	
Connectable indoor unit	Total capacity	50~130% of outdoor unit capacity				
	Max. quantity	64				
Compressor	Type	DC inverter+Fixed				
	Quantity	4+2				
Fan motor	Type	All DC motors for Heat pump series; DC+AC for Cooling only series				
	Quantity	4+2				
Refrigerant	Type	R410A				
	Factory charging	kg	9x2+16x2	9+13+13+16	9+13+16x2	
Pipe connections	Liquid pipe	mm	Φ22.2		Φ22.2	
	Gas pipe	mm	Φ41.3		Φ41.3	
	Oil balance pipe	mm	Φ6		Φ6	
Air flow rate	m <sup>3</sup> /h	11500x2+15250x2	11500+15100x2+15250		11500+15100+15250x2	
Sound pressure level	dB(A)	66				
Net dimension (WxHxD)	mm	(960x1615x765)x2+(1250x1615x765)x2	(960x1615x765)+(1250x1615x765)x3		(960x1615x765)+(1250x1615x765)x3	
Packing size (WxHxD)	mm	(1025x1790x830)x2+(1305x1790x820)x2	(1025x1790x830)+(1305x1790x820)x3		(1025x1790x830)+(1305x1790x820)x3	
Net weight (Heat pump series)	kg	200x2+300x2	200+280x2+300		200+280+300x2	
Gross weight (Heat pump series)	kg	215x2+320x2	215+300x2+320		215+300+320x2	
Net weight (Cooling only series)	kg	198x2+300x2	198+280x2+300		198+280+300x2	
Gross weight (Cooling only series)	kg	213x2+320x2	213+300x2+320		213+300+320x2	
Operating temperature range	°C	Cooling: -5-48; Heating*: -20-24				

**Notes:**

Capacities are based on the following conditions:  
 Cooling: Indoor temperature 27°C DB/19°C WB; Outdoor temperature 35°C DB/24°C WB; Heating: Indoor temperature 20°C DB/15°C WB; Outdoor temperature 7°C DB/6°C WB.  
 Piping length: Interconnecting piping length is 7.5m, level difference is zero.  
 Connection piping diameter of single-unit is the stop valve diameter of the unit.  
 Connection piping diameter of multi-unit is the main pipe connecting to the first indoor branch joint, in case of the total equivalent liquid length is less than 90m. If the total equivalent liquid length is more than 90m, please refer to technical manual to choose the connection piping diameter.  
 Sound values are measured in a semi-anechoic room, at a position 1m in front of the unit and 1.3m above the floor.  
 \*heating is only available for heat pump series.

## VRF V4 Plus K Series - Heat Pump/Cooling Only



HP	62		64		66	
Model (Heat pump series) MDV-	1730(62)W/DRN1(D)		1780(64)W/DRN1(D)		1850(66)W/DRN1(D)	
Model (Cooling only series) MDVC-	1730(62)W/DRN1(C)		1780(64)W/DRN1(C)		1850(66)W/DRN1(C)	
Combined type	10HP+16HP+18HPx2		10HP+18HPx3		14HP+16HP+18HPx2	
Power supply	V/Ph/Hz		380-415/3/50		380-415/3/50	
Cooling	Capacity	kW	173	178	185	
	Power input	kW	51.613	52.792	56.723	
	EER		3.35	3.37	3.29	
Heating*	Capacity	kW	193.5	199.5	207	
	Power input	kW	48.896	50.359	52.481	
	COP		3.96	3.96	3.94	
Connectable indoor unit	Total capacity	50~130% of outdoor unit capacity				
	Max. quantity	64				
Compressor	Type	DC inverter+Fixed				
	Quantity	4+3				
Fan motor	Type	All DC motors for Heat pump series; DC+AC for Cooling only series				
	Quantity	4+3				
Refrigerant	Type	R410A				
	Factory charging	kg	9+13+16x2	9+16x3	13x2+16x2	
Pipe connections	Liquid pipe	mm	Φ22.2		Φ25.4	
	Gas pipe	mm	Φ41.3		Φ44.5	
	Oil balance pipe	mm	Φ6		Φ6	
Air flow rate	m <sup>3</sup> /h	11500+15100+15250x2	11500+15250x3		15100x2+15250x2	
Sound pressure level	dB(A)	67				
Net dimension (WxHxD)	mm	(960x1615x765)+(1250x1615x765)x3				
Packing size (WxHxD)	mm	(1025x1790x830)+(1305x1790x820)x3				
Net weight (Heat pump series)	kg	200+280+300x2	200+300x3		280x2+300x2	
Gross weight (Heat pump series)	kg	215+300+320x2	215+320x3		300x2+320x2	
Net weight (Cooling only series)	kg	198+280+300x2	198+300x3		280x2+300x2	
Gross weight (Cooling only series)	kg	213+300+320x2	213+320x3		300x2+320x2	
Operating temperature range	°C	Cooling: -5-48; Heating*: -20-24				





HP	68		70		72	
Model (Heat pump series) MDV-	1900(68)W/DRN1(D)		1950(70)W/DRN1(D)		2000(72)W/DRN1(D)	
Model (Cooling only series) MDVC-	1900(68)W/DRN1(C)		1950(70)W/DRN1(C)		2000(72)W/DRN1(C)	
Combined type	14HP+18HPx3		16HP+18HPx3		18HPx4	
Power supply	V/Ph/Hz		380-415/3/50		380-415/3/50	
Cooling	Capacity	kW	190	195	200	
	Power input	kW	57.902	59.613	60.792	
	EER		3.28	3.27	3.29	
Heating*	Capacity	kW	213	218	224	
	Power input	kW	53.944	55.537	57	
	COP		3.95	3.93	3.93	
Connectable indoor unit	Total capacity	50~130% of outdoor unit capacity				
	Max. quantity	64				
Compressor	Type	DC inverter+Fixed				
	Quantity	4+4				
Fan motor	Type	All DC motors for Heat pump series; DC+AC for Cooling only series				
	Quantity	4+4				
Refrigerant	Type	R410A				
	Factory charging	kg	13+16x3	13+16x3	16x4	
Pipe connections	Liquid pipe	mm	Φ25.4		Φ25.4	
	Gas pipe	mm	Φ44.5		Φ44.5	
	Oil balance pipe	mm	Φ6		Φ6	
Air flow rate	m <sup>3</sup> /h	15100+15250x3	15100+15250x3		15250x4	
Sound pressure level	dB(A)	68				
Net dimension (WxHxD)	mm	(1250x1615x765)x4				
Packing size (WxHxD)	mm	(1305x1790x820)x4				
Net weight (Heat pump series)	kg	280+300x3	280+300x3		320x4	
Gross weight (Heat pump series)	kg	300+320x3	300+320x3		320x4	
Net weight (Cooling only series)	kg	280+300x3	280+300x3		320x4	
Gross weight (Cooling only series)	kg	300+320x3	300+320x3		320x4	
Operating temperature range	°C	Cooling: -5-48; Heating*: -20-24				

**Notes:**

Capacities are based on the following conditions:  
 Cooling: Indoor temperature 27°C DB/19°C WB; Outdoor temperature 35°C DB/24°C WB; Heating: Indoor temperature 20°C DB/15°C WB; Outdoor temperature 7°C DB/6°C WB.  
 Piping length: Interconnecting piping length is 7.5m, level difference is zero.  
 Connection piping diameter of single-unit is the stop valve diameter of the unit.  
 Connection piping diameter of multi-unit is the main pipe connecting to the first indoor branch joint, in case of the total equivalent liquid length is less than 90m. If the total equivalent liquid length is more than 90m, please refer to technical manual to choose the connection piping diameter.  
 Sound values are measured in a semi-anechoic room, at a position 1m in front of the unit and 1.3m above the floor.  
 \*heating is only available for heat pump series.



-  **Indoor Units**  
VRF V4 Plus indoor units
-  **Fresh Air Processing Unit**  
100% fresh air supply
-  **Ventilation**  
Heat recovery ventilator (HRV)
-  **AHU Connection Kit**  
Connect to other brand AHU
-  **Control Systems**  
Smart control systems



# VRF V4 Plus S Series Heat Pump

Optimized design  
for small to large  
buildings

- » ALL DC inverter compressors
- » ALL DC fan motors
- » Capacity up to 72HP
- » Connectable indoor units quantity up to 64
- » ESP up to 60Pa
- » Cycle duty operation
- » Backup operation
- » Precise oil control technology
- » Advanced silence technology
- » Intelligent defrosting technology
- » Simple communication wiring
- » Auto addressing
- » Easy maintenance

## High EER and COP Values »

V4 Plus S Series equipped with all DC compressors, all DC fan motors and high efficient heat exchanger. The cooling EER is up to 4.29 and the heating COP is up to 4.39 in the 8HP category.

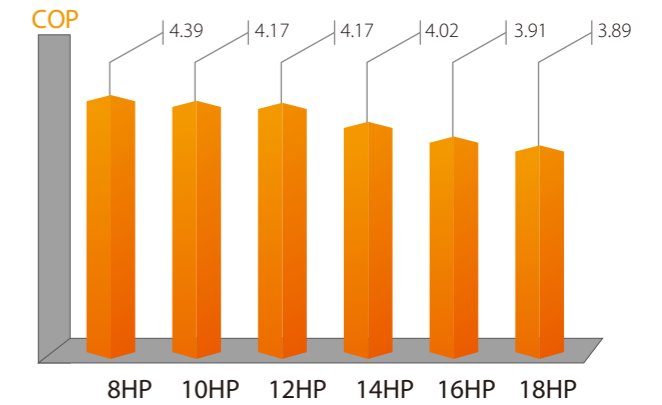
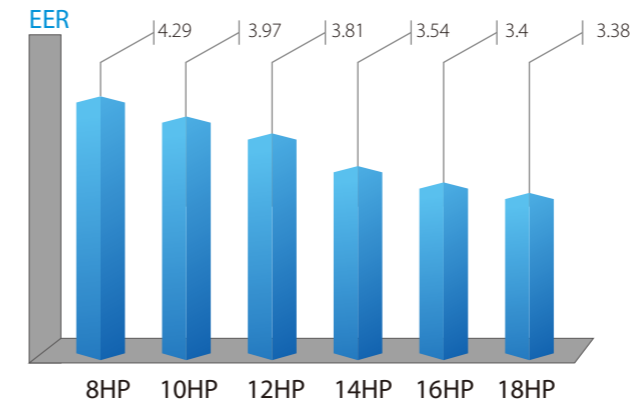

## Long Piping Length »

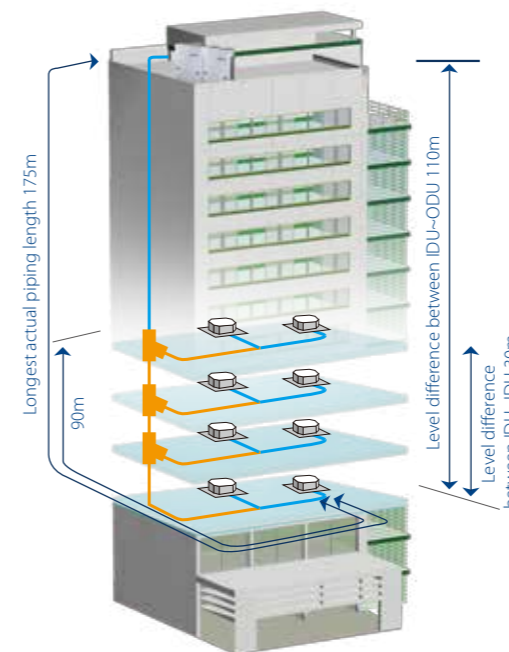

Total piping length	1000m
Longest length actual (Equivalent)	175(200)m
Longest length after first branch	90*m
Level difference between indoor and outdoor units - ODU up (down)	70(110)m
Level difference between indoor units	30m

\*The longest piping length is 40m standard. It can be extended to 90m. When the length is over 40m, please contact your local Midea dealer for more information and restrictions.

## VRF V4 Plus S Series - Heat Pump



HP	8		10		12		14		16		18	
Model MDV-	252(8)W/D2RN1(B)		280(10)W/D2RN1(B)		335(12)W/D2RN1(B)		400(14)W/D2RN1(B)		450(16)W/D2RN1(B)		500(18)W/D2RN1(B)	
Power supply	V/Ph/Hz 380-415/3/50											
Cooling	Capacity	kW	25.2	28.0	33.5	40.0	45.0	50.0				
	Power input	kW	5.88	7.05	8.79	11.30	13.25	14.79				
	EER		4.29	3.97	3.81	3.54	3.40	3.38				
Heating	Capacity	kW	27.0	31.5	37.5	45.0	50.0	56.0				
	Power input	kW	6.15	7.55	8.99	11.19	12.79	14.40				
	COP		4.39	4.17	4.17	4.02	3.91	3.89				
Connectable indoor unit	Total capacity	50~130% of outdoor unit capacity										
	Max. quantity	13	16	20	23	26	29					
Compressor	Type	DC inverter										
	Quantity	1	1	2	2	2	2					
Fan motor	Type	DC motor										
	Quantity	1	1	2	2	2	2					
Static pressure	Pa	0-20 (default)										
	Pa	20-40 (customized)		20-60 (customized)		20-40 (customized)						
Refrigerant	Type	R410A										
	Factory charging	kg	10	10	12	15	15	16				
Pipe connections	Liquid pipe	mm	Φ12.7	Φ12.7	Φ15.9	Φ15.9	Φ15.9	Φ19.1				
	Gas pipe	mm	Φ25.4	Φ25.4	Φ31.8	Φ31.8	Φ31.8	Φ31.8				
	Oil balance pipe	mm	Φ6	Φ6	Φ6	Φ6	Φ6	Φ6				
	Oil balance pipe	mm	Φ6	Φ6	Φ6	Φ6	Φ6	Φ6				
Air flow rate	m <sup>3</sup> /h	11242	11242	13000	15620	15620	15620					
Sound pressure level	dB(A)	57	57	59	61	62	62					
Net dimension (WxHxD)	mm	960x1615x765			1250x1615x765							
Packing size (WxHxD)	mm	1025x1790x830			1305x1790x820							
Net weight	kg	212	212	288	288	288	310					
Gross weight	kg	227	227	308	308	308	330					
Operating temperature range	°C	Cooling: -5-48; Heating: -20-24										



HP	20		22		24		26		28		
Model MDV-	560(20)W/D2RN1(B)		615(22)W/D2RN1(B)		680(24)W/D2RN1(B)		730(26)W/D2RN1(B)		780(28)W/D2RN1(B)		
Combined type	10HPx2										
Power supply	V/Ph/Hz 380-415/3/50										
Cooling	Capacity	kW	56.0	61.5	68.0	73.0	78.0				
	Power input	kW	14.11	15.85	18.35	20.29	21.85				
	EER		3.97	3.88	3.71	3.60	3.57				
Heating	Capacity	kW	63.0	69.0	76.5	81.5	87.5				
	Power input	kW	15.11	16.55	18.75	20.34	21.95				
	COP		4.17	4.17	4.08	4.01	3.99				
Connectable indoor unit	Total capacity	50~130% of outdoor unit capacity									
	Max. quantity	33	36	39	43	46					
Compressor	Type	DC inverter									
	Quantity	2	3	3	3	3					
Fan motor	Type	DC motor									
	Quantity	2	3	3	3	3					
Refrigerant	Type	R410A									
	Factory charging	kg	10x2	10+12	10+15	10+15	10+16				
Pipe connections	Liquid pipe	mm	Φ15.9	Φ15.9	Φ15.9	Φ19.1	Φ19.1				
	Gas pipe	mm	Φ28.6	Φ28.6	Φ28.6	Φ31.8	Φ31.8				
	Oil balance pipe	mm	Φ6	Φ6	Φ6	Φ6	Φ6				
	Oil balance pipe	mm	Φ6	Φ6	Φ6	Φ6	Φ6				
Air flow rate	m <sup>3</sup> /h	11242x2	11242+13000	11242+15620	11242+15620	11242+15620					
Sound pressure level	dB(A)	62	63	63	63	63					
Net dimension (WxHxD)	mm	(960x1615x765)x2		(960x1615x765)+(1250x1615x765)							
Packing size (WxHxD)	mm	(1025x1790x830)x2		(1025x1790x830)+(1305x1790x820)							
Net weight	kg	212x2	212+288	212+288	212+288	212+310					
Gross weight	kg	227x2	227+308	227+308	227+308	227+330					
Operating temperature range	°C	Cooling: -5-48; Heating: -20-24									

Notes:

Capacities are based on the following conditions:

Cooling: Indoor temperature 27°C DB/19°C WB; Outdoor temperature 35°C DB/24°C WB; Heating: Indoor temperature 20°C DB/15°C WB; Outdoor temperature 7°C DB/6°C WB.

Piping length: Interconnecting piping length is 7.5m, level difference is zero.

Connection piping diameter of single-unit is the stop valve diameter of the unit.

Connection piping diameter of multi-unit is the main pipe connecting to the first indoor branch joint, in case of the total equivalent liquid length is less than 90m. If the total equivalent liquid length is more than 90m, please refer to technical manual to choose the connection piping diameter.

Sound values are measured in a semi-anechoic room, at a position 1m in front of the unit and 1.3m above the floor.

## VRF V4 Plus S Series - Heat Pump



HP	30		32		34		36		38		
Model MDV-	850(30)W/D2RN1(B)		900(32)W/D2RN1(B)		950(34)W/D2RN1(B)		1000(36)W/D2RN1(B)		1060(38)W/D2RN1(B)		
Combined type	14HP+16HP										
Power supply	V/Ph/Hz 380-415/3/50										
Cooling	Capacity	kW	85.0	90.0	95.0	100.0	106.0				
	Power input	kW	24.53	26.09	28.03	29.59	28.90				
	EER		3.46	3.45	3.39	3.38	3.67				
Heating	Capacity	kW	95.0	101.0	106.0	112.0	119.0				
	Power input	kW	23.98	25.59	27.18	28.79	29.50				
	COP		3.96	3.95	3.90	3.89	4.03				
Connectable indoor unit	Total capacity	50~130% of outdoor unit capacity									
	Max. quantity	50	53	56	59	63					
Compressor	Type	DC inverter									
	Quantity	4	4	4	4	4					
Fan motor	Type	DC motor									
	Quantity	4	4	4	4	4					
Refrigerant	Type	R410A									
	Factory charging	kg	15+15	15+16	15+16	16x2	10x2+16				
Pipe connections	Liquid pipe	mm	Φ19.1	Φ19.1	Φ19.1	Φ19.1	Φ19.1				
	Gas pipe	mm	Φ31.8	Φ31.8	Φ31.8	Φ31.8	Φ31.8				
	Oil balance pipe	mm	Φ6	Φ6	Φ6	Φ6	Φ6				
	Oil balance pipe	mm	Φ6	Φ6	Φ6	Φ6	Φ6				
Air flow rate	m <sup>3</sup> /h	15620x2	15620x2	15620x2	15620x2	15620x2					
Sound pressure level	dB(A)	64	64	64	64	64					
Net dimension (WxHxD)	mm	(1250x1615x765)x2									
Packing size (WxHxD)	mm	(1305x1790x820)x2									
Net weight	kg	288x2	288+310	288+310	288+310	310x2	212x2+310				
Gross weight	kg	308x2	308+330	308+330	308+330	330x2	227x2+330				
Operating temperature range	°C	Cooling: -5-48; Heating: -20-24									



HP	40		42		44		46		48		
Model MDV-	1130(40)W/D2RN1(B)		1180(42)W/D2RN1(B)		1230(44)W/D2RN1(B)		1280(46)W/D2RN1(B)		1350(48)W/D2RN1(B)		
Combined type	10HP+14HP+16HP										
Power supply	V/Ph/Hz 380-415/3/50										
Cooling	Capacity	kW	113.0	118.0	123.0	128.0	135.0				
	Power input	kW	31.59	33.52	35.08	36.64	39.33				
	EER		3.58	3.52	3.51	3.49	3.43				
Heating	Capacity	kW	126.5	131.5	137.5	143.5	151.0				
	Power input	kW	31.54	33.13	34.74	36.35	38.38				
	COP		4.01	3.97	3.96	3.95	3.93				
Connectable indoor unit	Total capacity	50~130% of outdoor unit capacity									
	Max. quantity	64	64	64	64	64					
Compressor	Type	DC inverter									
	Quantity	5	5	5	5	6					
Fan motor	Type	DC motor									
	Quantity	5	5	5	5	6					
Refrigerant	Type	R410A									
	Factory charging	kg	10+15x2	10+15x2	10+15+16	10+16x2	15x2+16				
Pipe connections	Liquid pipe	mm	Φ19.1	Φ19.1	Φ19.1	Φ19.1	Φ19.1				
	Gas pipe	mm	Φ38.1	Φ38.1	Φ38.1	Φ38.1	Φ38.1				
	Oil balance pipe	mm	Φ6	Φ6	Φ6	Φ6	Φ6				
	Oil balance pipe	mm	Φ6	Φ6	Φ6	Φ6	Φ6				
Air flow rate	m <sup>3</sup> /h	11242+15620x2									
Sound pressure level	dB(A)	65									
Net dimension (WxHxD)	mm	(960x1615x765)+(1250x1615x765)x2									
Packing size (WxHxD)	mm	(1025x1790x830)+(1305x1790x820)x2									
Net weight	kg	212+288x2	212+288x2	212+288+310	212+310x2	288x2+310					
Gross weight	kg	227+308x2	227+308x2	227+308+330	227+330x2	308x2+330					
Operating temperature range	°C	Cooling: -5-48; Heating: -20-24									

Notes:

Capacities are based on the following conditions:

Cooling: Indoor temperature 27°C DB/19°C WB; Outdoor temperature 35°C DB/24°C WB; Heating: Indoor temperature 20°C DB/15°C WB; Outdoor temperature 7°C DB/6°C WB.

Piping length: Interconnecting piping length is 7.5m, level difference is zero.

Connection piping diameter of single-unit is the stop valve diameter of the unit.

Connection piping diameter of multi-unit is the main pipe connecting to the first indoor branch joint, in case of the total equivalent liquid length is less than 90m. If the total equivalent liquid length is more than 90m, please refer to technical manual to choose the connection piping diameter.

Sound values are measured in a semi-anechoic room, at a position 1m in front of the unit and 1.3m above the floor.



## VRF V4 Plus S Series - Heat Pump



HP	50		52		54	
Model MDV-	1400(50)W/D2RN1(B)		1450(52)W/D2RN1(B)		1500(54)W/D2RN1(B)	
Combined type	14HP+18HPx2		16HP+18HPx2		18HPx3	
Power supply	V/Ph/Hz		380-415/3/50			
Cooling	Capacity	kW	140.0	145.0	150.0	
	Power input	kW	40.89	42.82	44.38	
	EER		3.42	3.39	3.38	
Heating	Capacity	kW	157.0	162.0	168.0	
	Power input	kW	39.99	41.58	43.19	
	COP		3.93	3.90	3.89	
Connectable indoor unit	Total capacity	50~130% of outdoor unit capacity				
	Max. quantity	64				
Compressor	Type	DC inverter				
	Quantity	6				
Fan motor	Type	DC motor				
	Quantity	6				
Refrigerant	Type	R410A				
	Factory charging	kg	15+16x2	15+16x2	16x3	
Pipe connections	Liquid pipe	mm	Φ22.2			
	Gas pipe	mm	Φ41.2			
	Oil balance pipe	mm	Φ6			
Air flow rate	m <sup>3</sup> /h	15620x3				
Sound pressure level	dB(A)	66				
Net dimension (WxHxD)	mm	(1250x1615x765)x3				
Packing size (WxHxD)	mm	(1305x1790x820)x3				
Net weight	kg	288+310x2	288+310x2	310x3		
Gross weight	kg	308+330x2	308+330x2	330x3		
Operating temperature range	°C	Cooling: -5-48; Heating: -20-24				



HP	56		58		60	
Model MDV-	1560(56)W/D2RN1(B)		1630(58)W/D2RN1(B)		1680(60)W/D2RN1(B)	
Combined type	10HPx2+18HPx2		10HP+14HP+16HP+18HP		10HP+14HP+18HPx2	
Power supply	V/Ph/Hz		380-415/3/50			
Cooling	Capacity	kW	156.0	163.0	168.0	
	Power input	kW	43.69	46.38	47.94	
	EER		3.57	3.51	3.50	
Heating	Capacity	kW	175.0	182.5	188.5	
	Power input	kW	43.90	45.93	47.54	
	COP		3.99	3.97	3.97	
Connectable indoor unit	Total capacity	50~130% of outdoor unit capacity				
	Max. quantity	64				
Compressor	Type	DC inverter				
	Quantity	6				
Fan motor	Type	DC motor				
	Quantity	6				
Refrigerant	Type	R410A				
	Factory charging	kg	10x2+16x2	10+15x2+16	10+15+16x2	
Pipe connections	Liquid pipe	mm	Φ22.2			
	Gas pipe	mm	Φ41.2			
	Oil balance pipe	mm	Φ6			
Air flow rate	m <sup>3</sup> /h	11242x2+15620x2	11242+15620x3	11242+15620x3		
Sound pressure level	dB(A)	66	67	67		
Net dimension (WxHxD)	mm	(960x1615x765)x2+(1250x1615x765)x2	(960x1615x765)+(1250x1615x765)x3			
Packing size (WxHxD)	mm	(1025x1790x830)x2+(1305x1790x820)x2	(1025x1790x830)+(1305x1790x820)x3			
Net weight	kg	212x2+310x2	212+288x2+310	212+288+310x2		
Gross weight	kg	227x2+330x2	227+308x2+330	227+308+330x2		
Operating temperature range	°C	Cooling: -5-48; Heating: -20-24				

Notes:  
 Capacities are based on the following conditions:  
 Cooling: Indoor temperature 27°C DB/19°C WB; Outdoor temperature 35°C DB/24°C WB; Heating: Indoor temperature 20°C DB/15°C WB; Outdoor temperature 7°C DB/6°C WB.  
 Piping length: Interconnecting piping length is 7.5m, level difference is zero.  
 Connection piping diameter of single-unit is the stop valve diameter of the unit.  
 Connection piping diameter of multi-unit is the main pipe connecting to the first indoor branch joint, in case of the total equivalent liquid length is less than 90m. If the total equivalent liquid length is more than 90m, please refer to technical manual to choose the connection piping diameter.  
 Sound values are measured in a semi-anechoic room, at a position 1m in front of the unit and 1.3m above the floor.

## VRF V4 Plus S Series - Heat Pump





HP	62		64		66	
Model MDV-	1730(62)W/D2RN1(B)		1780(64)W/D2RN1(B)		1850(66)W/D2RN1(B)	
Combined type	10HP+16HP+18HPx2		10HP+18HPx3		14HP+16HP+18HPx2	
Power supply	V/Ph/Hz		380-415/3/50			
Cooling	Capacity	kW	173.0	178.0	185.0	
	Power input	kW	49.87	51.43	54.12	
	EER		3.47	3.46	3.42	
Heating	Capacity	kW	193.5	199.5	207.0	
	Power input	kW	49.13	50.74	52.77	
	COP		3.94	3.93	3.92	
Connectable indoor unit	Total capacity	50~130% of outdoor unit capacity				
	Max. quantity	64				
Compressor	Type	DC inverter				
	Quantity	7				
Fan motor	Type	DC motor				
	Quantity	7				
Refrigerant	Type	R410A				
	Factory charging	kg	10+15+16x2	10+16x3	15x2+16x2	
Pipe connections	Liquid pipe	mm	Φ22.2			
	Gas pipe	mm	Φ41.2			
	Oil balance pipe	mm	Φ6			
Air flow rate	m <sup>3</sup> /h	11242+15620x3	11242+15620x3			15620x4
Sound pressure level	dB(A)	67	67			68
Net dimension (WxHxD)	mm	(960x1615x765)+(1250x1615x765)x3				(1250x1615x765)x4
Packing size (WxHxD)	mm	(1025x1790x830)+(1305x1790x820)x3				(1305x1790x820)x4
Net weight	kg	212+288+310x2	212+310x3			288x2+310x2
Gross weight	kg	227+308+330x2	227+330x3			308x2+330x2
Operating temperature range	°C	Cooling: -5-48; Heating: -20-24				



HP	68		70		72	
Model MDV-	1900(68)W/D2RN1(B)		1950(70)W/D2RN1(B)		2000(72)W/D2RN1(B)	
Combined type	14HP+18HPx3		16HP+18HPx3		18HPx4	
Power supply	V/Ph/Hz		380-415/3/50			
Cooling	Capacity	kW	190.0	195.0	200.0	
	Power input	kW	55.68	57.61	59.17	
	EER		3.41	3.38	3.38	
Heating	Capacity	kW	213.0	218.0	224.0	
	Power input	kW	54.38	55.98	57.58	
	COP		3.92	3.89	3.89	
Connectable indoor unit	Total capacity	50~130% of outdoor unit capacity				
	Max. quantity	64				
Compressor	Type	DC inverter				
	Quantity	8				
Fan motor	Type	DC motor				
	Quantity	8				
Refrigerant	Type	R410A				
	Factory charging	kg	15+16x3	15+16x3	16x4	
Pipe connections	Liquid pipe	mm	Φ25.4			
	Gas pipe	mm	Φ44.5			
	Oil balance pipe	mm	Φ6			
Air flow rate	m <sup>3</sup> /h	15620x4				
Sound pressure level	dB(A)	68				
Net dimension (WxHxD)	mm	(1250x1615x765)x4				
Packing size (WxHxD)	mm	(1305x1790x820)x4				
Net weight	kg	288+310x3	288+310x3			310x4
Gross weight	kg	308+330x3	308+330x3			330x4
Operating temperature range	°C	Cooling: -5-48; Heating: -20-24				

Notes:  
 Capacities are based on the following conditions:  
 Cooling: Indoor temperature 27°C DB/19°C WB; Outdoor temperature 35°C DB/24°C WB; Heating: Indoor temperature 20°C DB/15°C WB; Outdoor temperature 7°C DB/6°C WB.  
 Piping length: Interconnecting piping length is 7.5m, level difference is zero.  
 Connection piping diameter of single-unit is the stop valve diameter of the unit.  
 Connection piping diameter of multi-unit is the main pipe connecting to the first indoor branch joint, in case of the total equivalent liquid length is less than 90m. If the total equivalent liquid length is more than 90m, please refer to technical manual to choose the connection piping diameter.  
 Sound values are measured in a semi-anechoic room, at a position 1m in front of the unit and 1.3m above the floor.

-  **Indoor Units**  
VRF V4 Plus indoor units
-  **Ventilation**  
Heat recovery ventilator (HRV)
-  **Control Systems**  
Smart control systems



# VRF V4 Plus R Series Heat Recovery

Offers simultaneous cooling and heating operation in one system

- »» ALL DC inverter compressors
- »» ALL DC fan motors
- »» Capacity up to 64HP
- »» Connectable indoor units quantity up to 64
- »» ESP up to 60Pa
- »» Cycle duty operation
- »» Backup operation
- »» Precise oil control technology
- »» Advanced silence technology
- »» Simple communication wiring
- »» Remote addressing
- »» Easy maintenance

## Heat Recovery, EER up to 7.0 »»

Heat recovery is achieved by diverting exhaust heat from indoor units in cooling mode to areas requiring heating, maximizing energy efficiency, reducing electricity costs and leading to high partload efficiencies (up to 7.0 in the 8HP category).

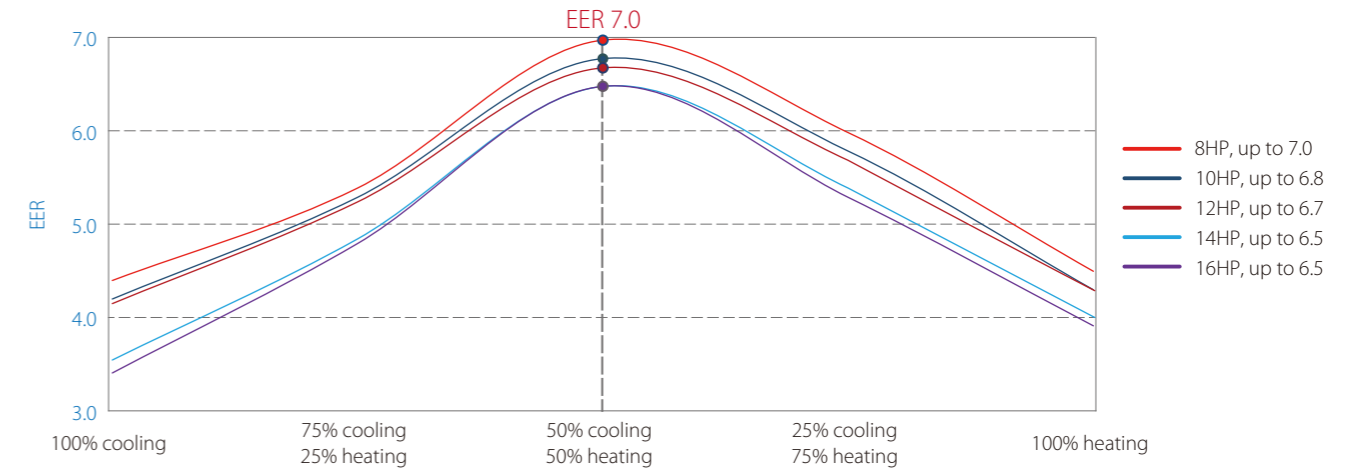

EER in simultaneous cooling and heating mode are based on the following condition:  
Outdoor temperature 7°CDB/6°CWB, indoor temperature 27°CDB/19°CWB for cooling, indoor temperature 20°CDB for heating.

## Long Piping Length »»

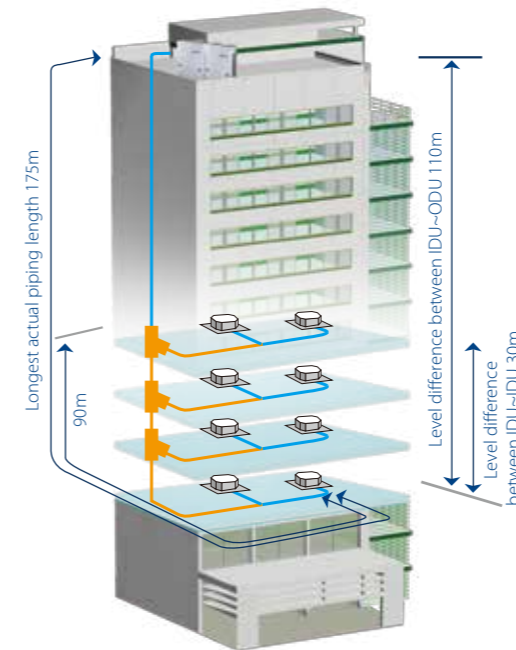

Total piping length	1000m
Longest length actual (Equivalent)	175(200)m
Longest length after first branch	90*m
Longest length from MS to its downstream indoor unit	40m
Level difference between indoor and outdoor units - ODU up (down)	70(110)m
Level difference between indoor units	30m

\*The longest piping length is 40m standard. It can be extended to 90m. When the length is over 40m, please contact your local Midea dealer for more information and restrictions.



### Adjustable Outdoor Heat Exchanger >>

Two parts condenser individual design, the unit can distribute a part of evaporator to be as condensing area according to the heating load requirement to improve the utilization rate of the condenser.

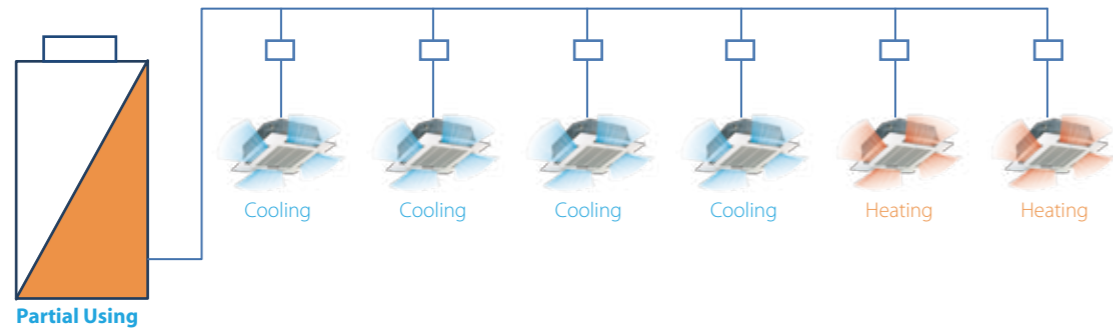

### Continuous Heating During Defrost Operation >>

Each heat exchanger is defrosted by using heat transferred from one heat exchanger to the other in the outdoor unit. Defrost has no impact on the indoor unit on heating mode.

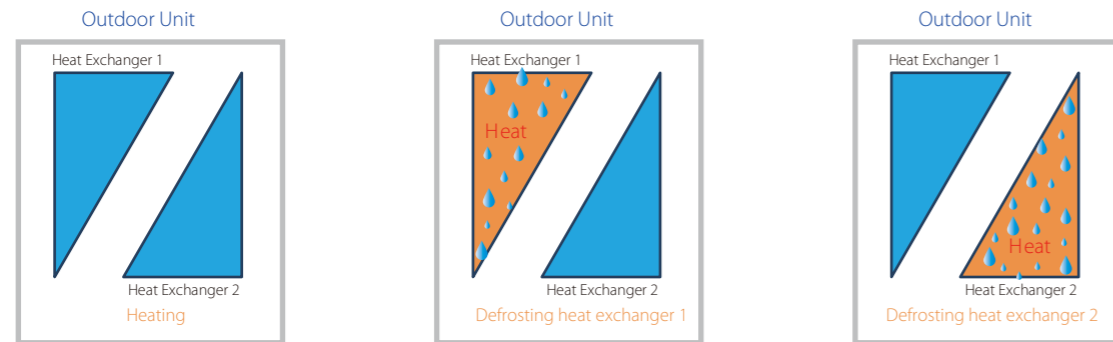

### Auto Mode Control >>

Under the Auto Mode, the indoor unit can change the operation mode automatically, to keep the indoor temperature at a constant level.

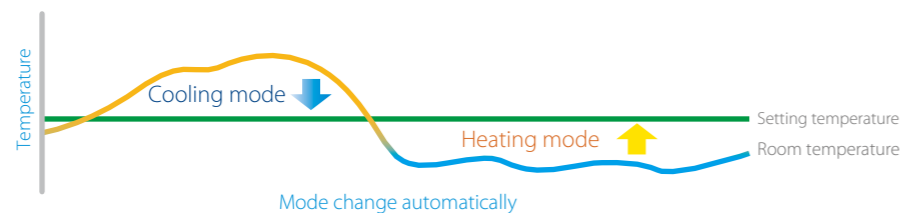

Note: Auto Mode can be activated only with certain wired controller KJR-120B.

### Innovative Mode Switch (MS) Box >>

Simultaneous cooling and heating achieved for new designed MS (Mode Switch) box.

- ❖ Low noise operation for precise control of multiple solenoid valves;
- ❖ Max. 24 indoor units connect to a MS box;
- ❖ Max. 56kW indoor units connect to a MS box;



- ❖ Indoor units connected to a same MS can realize simultaneous cooling and heating operation.

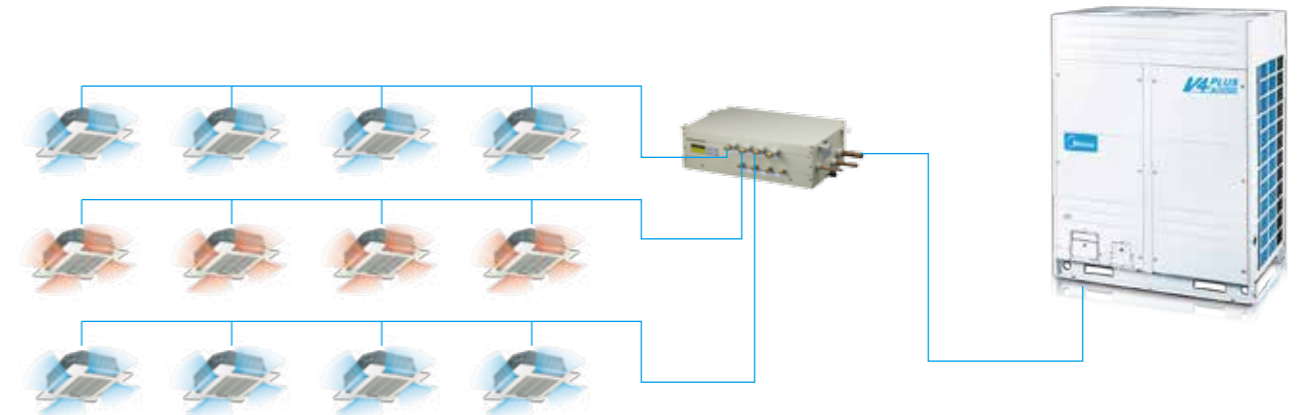

### Rotatable Control Box >>

Newly designed rotating control box can rotate in a wide angle. It is convenient for the inspection and maintenance of the pipeline system and greatly reduces the dismount time of the electric control box.



## VRF V4 Plus R Series - Heat Recovery



HP	8		10		12		14		16		
Model MDV-	252(8)W/D2RN1T(C)		280(10)W/D2RN1T(C)		335(12)W/D2RN1T(C)		400(14)W/D2RN1T(C)		450(16)W/D2RN1T(C)		
Combined type	380-415/3/50										
Power supply	V/Ph/Hz										
Cooling	Capacity	kW	25.2	28	33.5	40	45				
	Power input	kW	5.73	6.67	8.07	11.3	13.24				
	EER		4.4	4.2	4.15	3.54	3.4				
Heating	Capacity	kW	27	31.5	37.5	45	50				
	Power input	kW	6	7.33	8.72	11.19	12.79				
	COP		4.5	4.3	4.3	4.02	3.91				
Connectable indoor unit	Total capacity	50~130% of outdoor unit capacity									
	Max. quantity		13	16	20	23	26				
Compressor	Type	DC inverter									
	Quantity		1	1	1	2	2				
Fan motor	Type	DC motor									
	Quantity		2	2	2	2	2				
	Static pressure	Pa	20-40 (customized)		0-20 (default)		20-40 (customized)				
Refrigerant	Type	R410A									
	Factory charging	kg	10	10	10	13	13				
Pipe connections	Liquid pipe	mm	Φ12.7	Φ12.7	Φ15.9	Φ15.9	Φ15.9				
	Low pressure gas pipe	mm	Φ22.2	Φ22.2	Φ25.4	Φ28.6	Φ28.6				
	High pressure gas pipe	mm	Φ19.1	Φ19.1	Φ19.1	Φ22.2	Φ22.2				
	High pressure gas balance pipe	mm	Φ19.1	Φ19.1	Φ19.1	Φ19.1	Φ19.1				
	Oil balance pipe	mm	Φ6	Φ6	Φ6	Φ6	Φ6				
Air flow rate	m <sup>3</sup> /h	12000	12000	13000	15000	15000					
Sound pressure level	dB(A)	57	57	58	60	60					
Net dimension (WxHxD)	mm	1250x1615x765									
Packing size (WxHxD)	mm	1305x1790x820									
Net weight	kg	255	255	255	303	303					
Gross weight	kg	273	273	273	322	322					
Operating temperature range	°C	Cooling: -5~48; Heating: -20~24; Simultaneous Cooling and Heating: -5~24									



HP	18		20		22		24		
Model MDV-	532(18)W/D2RN1T(C)		560(20)W/D2RN1T(C)		615(22)W/D2RN1T(C)		680(24)W/D2RN1T(C)		
Combined type	8HP+10HP								
Power supply	V/Ph/Hz	380-415/3/50							
Cooling	Capacity	kW	53.2	56	61.5	68			
	Power input	kW	12.4	13.34	14.74	17.97			
	EER		4.29	4.2	4.17	3.78			
Heating	Capacity	kW	58.5	63	69	76.5			
	Power input	kW	13.33	14.66	16.05	18.52			
	COP		4.39	4.3	4.3	4.13			
Connectable indoor unit	Total capacity	50~130% of outdoor unit capacity							
	Max. quantity		29	33	36	39			
Compressor	Type	DC inverter							
	Quantity		2	2	2	3			
Fan motor	Type	DC motor							
	Quantity		4	4	4	4			
Refrigerant	Type	R410A							
	Factory charging	kg	10x2	10x2	10x2	10+13			
Pipe connections	Liquid pipe	mm	Φ15.9	Φ15.9	Φ15.9	Φ15.9			
	Low pressure gas pipe	mm	Φ31.8	Φ31.8	Φ31.8	Φ34.9			
	High pressure gas pipe	mm	Φ28.6	Φ28.6	Φ28.6	Φ28.6			
	High pressure gas balance pipe	mm	Φ19.1	Φ19.1	Φ19.1	Φ19.1			
	Oil balance pipe	mm	Φ6	Φ6	Φ6	Φ6			
Air flow rate	m <sup>3</sup> /h	24000	24000	25000	27000				
Sound pressure level	dB(A)	61	61	62	63				
Net dimension (WxHxD)	mm	(1250x1615x765)x2							
Packing size (WxHxD)	mm	(1305x1790x820)x2							
Net weight	kg	255x2	255x2	255x2	255+303				
Gross weight	kg	273x2	273x2	273x2	273+322				
Operating temperature range	°C	Cooling: -5~48; Heating: -20~24; Simultaneous Cooling and Heating: -5~24							

Notes:  
 Capacities are based on the following conditions:  
 Cooling: Indoor temperature 27°C DB/19°C WB; Outdoor temperature 35°C DB/24°C WB; Heating: Indoor temperature 20°C DB/15°C WB; Outdoor temperature 7°C DB/6°C WB.  
 Piping length: Interconnecting piping length is 7.5m, level difference is zero.  
 Connection piping diameter of single-unit is the stop valve diameter of the unit.  
 Connection piping diameter of multi-unit is the main pipe connecting to the first indoor branch joint, in case of the total equivalent liquid length is less than 90m. If the total equivalent liquid length is more than 90m, please refer to technical manual to choose the connection piping diameter.  
 Sound values are measured in a semi-anechoic room, at a position 1m in front of the unit and 1.3m above the floor.

## VRF V4 Plus R Series - Heat Recovery



HP	26		28		30		32			
Model MDV-	730(26)W/D2RN1T(C)		800(28)W/D2RN1T(C)		850(30)W/D2RN1T(C)		900(32)W/D2RN1T(C)			
Combined type	10HP+16HP									
Power supply	V/Ph/Hz	380-415/3/50								
Cooling	Capacity	kW	73	80	85	90				
	Power input	kW	19.9	22.6	24.54	26.48				
	EER		3.67	3.54	3.46	3.4				
Heating	Capacity	kW	81.5	90	95	100				
	Power input	kW	20.1	22.4	23.98	25.58				
	COP		4.05	4.02	3.96	3.91				
Connectable indoor unit	Total capacity	50~130% of outdoor unit capacity								
	Max. quantity		43	46	50	53				
Compressor	Type	DC inverter								
	Quantity		3	4	4	4				
Fan motor	Type	DC motor								
	Quantity		4	4	4	4				
Refrigerant	Type	R410A								
	Factory charging	kg	10+13	13x2	13x2	13x2				
Pipe connections	Liquid pipe	mm	Φ19.1							
	Low pressure gas pipe	mm	Φ34.9							
	High pressure gas pipe	mm	Φ28.6							
	High pressure gas balance pipe	mm	Φ19.1							
	Oil balance pipe	mm	Φ6							
Air flow rate	m <sup>3</sup> /h	27000	30000	30000	30000	30000				
Sound pressure level	dB(A)	63	64	64	64	64				
Net dimension (WxHxD)	mm	(1250x1615x765)x2								
Packing size (WxHxD)	mm	(1305x1790x820)x2								
Net weight	kg	255+303	303x2	303x2	303x2	303x2				
Gross weight	kg	273+322	322x2	322x2	322x2	322x2				
Operating temperature range	°C	Cooling: -5~48; Heating: -20~24; Simultaneous Cooling and Heating: -5~24								



HP	34		36		38		40			
Model MDV-	960(34)W/D2RN1T(C)		1010(36)W/D2RN1T(C)		1065(38)W/D2RN1T(C)		1130(40)W/D2RN1T(C)			
Combined type	10HPx2+14HP									
Power supply	V/Ph/Hz	380-415/3/50								
Cooling	Capacity	kW	96	101	106.5	113				
	Power input	kW	24.64	26.58	27.98	31.21				
	EER		3.9	3.8	3.81	3.62				
Heating	Capacity	kW	108	113	119	126.5				
	Power input	kW	25.85	27.45	28.84	31.31				
	COP		4.18	4.12	4.13	4.04				
Connectable indoor unit	Total capacity	50~130% of outdoor unit capacity								
	Max. quantity		56	59	63	64				
Compressor	Type	DC inverter								
	Quantity		4	4	4	5				
Fan motor	Type	DC motor								
	Quantity		6	6	6	6				
Refrigerant	Type	R410A								
	Factory charging	kg	10x2+13	10x2+13	10x2+13	10+13x2				
Pipe connections	Liquid pipe	mm	Φ19.1							
	Low pressure gas pipe	mm	Φ41.3							
	High pressure gas pipe	mm	Φ34.9							
	High pressure gas balance pipe	mm	Φ19.1							
	Oil balance pipe	mm	Φ6							
Air flow rate	m <sup>3</sup> /h	39000	39000	40000	42000					
Sound pressure level	dB(A)	65	65	65	66					
Net dimension (WxHxD)	mm	(1250x1615x765)x3								
Packing size (WxHxD)	mm	(1305x1790x820)x3								
Net weight	kg	255x2+303	255x2+303	255x2+303	255+303x2					
Gross weight	kg	273x2+322	273x2+322	273x2+322	273+322x2					
Operating temperature range	°C	Cooling: -5~48; Heating: -20~24; Simultaneous Cooling and Heating: -5~24								

Notes:  
 Capacities are based on the following conditions:  
 Cooling: Indoor temperature 27°C DB/19°C WB; Outdoor temperature 35°C DB/24°C WB; Heating: Indoor temperature 20°C DB/15°C WB; Outdoor temperature 7°C DB/6°C WB.  
 Piping length: Interconnecting piping length is 7.5m, level difference is zero.  
 Connection piping diameter of single-unit is the stop valve diameter of the unit.  
 Connection piping diameter of multi-unit is the main pipe connecting to the first indoor branch joint, in case of the total equivalent liquid length is less than 90m. If the total equivalent liquid length is more than 90m, please refer to technical manual to choose the connection piping diameter.  
 Sound values are measured in a semi-anechoic room, at a position 1m in front of the unit and 1.3m above the floor.



## VRF V4 Plus R Series - Heat Recovery



HP	42		44		46		48		
Model MDV-	1200(42)W/D2RN1T(C)		1250(44)W/D2RN1T(C)		1300(46)W/D2RN1T(C)		1350(48)W/D2RN1T(C)		
Combined type	14HPx3		14HPx2+16HP		14HP+16HPx2		16HPx3		
Power supply	V/Ph/Hz		380-415/3/50		380-415/3/50		380-415/3/50		
Cooling	Capacity	kW	120	125	130	135			
	Power input	kW	33.9	35.84	37.78	39.72			
	EER		3.54	3.49	3.44	3.4			
Heating	Capacity	kW	135	140	145	150			
	Power input	kW	33.57	35.17	36.77	38.37			
	COP		4.02	3.98	3.94	3.91			
Connectable indoor unit	Total capacity	50~130% of outdoor unit capacity							
	Max. quantity	64							
Compressor	Type	DC inverter							
	Quantity	6							
Fan motor	Type	DC motor							
	Quantity	6							
Refrigerant	Type	R410A							
	Factory charging	kg	13x3						
Pipe connections	Liquid pipe	mm	Φ19.1						
	Low pressure gas pipe	mm	Φ41.3						
	High pressure gas pipe	mm	Φ34.9						
	High pressure gas balance pipe	mm	Φ19.1						
	Oil balance pipe	mm	Φ6						
Air flow rate	m <sup>3</sup> /h	45000							
Sound pressure level	dB(A)	67							
Net dimension (WxHxD)	mm	(1250x1615x765)x3							
Packing size (WxHxD)	mm	(1305x1790x820)x3							
Net weight	kg	303x3							
Gross weight	kg	322x3							
Operating temperature range	°C	Cooling: -5~48; Heating: -20~24; Simultaneous Cooling and Heating: -5~24							



HP	50		52		54		56		
Model MDV-	1432(50)W/D2RN1T(C)		1460(52)W/D2RN1T(C)		1515(54)W/D2RN1T(C)		1580(56)W/D2RN1T(C)		
Combined type	8HP+10HP+16HPx2		10HPx2+16HPx2		10HP+12HP+16HPx2		10HP+14HP+16HPx2		
Power supply	V/Ph/Hz		380-415/3/50		380-415/3/50		380-415/3/50		
Cooling	Capacity	kW	143.2	146	151.5	158			
	Power input	kW	38.88	39.82	41.22	44.45			
	EER		3.68	3.67	3.68	3.55			
Heating	Capacity	kW	158.5	163	169	176.5			
	Power input	kW	38.91	40.24	41.63	44.1			
	COP		4.07	4.05	4.06	4			
Connectable indoor unit	Total capacity	50~130% of outdoor unit capacity							
	Max. quantity	64							
Compressor	Type	DC inverter							
	Quantity	6							
Fan motor	Type	DC motor							
	Quantity	8							
Refrigerant	Type	R410A							
	Factory charging	kg	10x2+13x2	10x2+13x2	10x2+13x2	10+13x3			
Pipe connections	Liquid pipe	mm	Φ22.2						
	Low pressure gas pipe	mm	Φ44.5						
	High pressure gas pipe	mm	Φ38.1						
	High pressure gas balance pipe	mm	Φ19.1						
	Oil balance pipe	mm	Φ6						
Air flow rate	m <sup>3</sup> /h	54000	54000	55000	57000				
Sound pressure level	dB(A)	68							
Net dimension (WxHxD)	mm	(1250x1615x765)x4							
Packing size (WxHxD)	mm	(1305x1790x820)x4							
Net weight	kg	255x2+303x2	255x2+303x2	255x2+303x2	255+303x3				
Gross weight	kg	273x2+322x2	273x2+322x2	273x2+322x2	273+322x3				
Operating temperature range	°C	Cooling: -5~48; Heating: -20~24; Simultaneous Cooling and Heating: -5~24							

Notes:  
 Capacities are based on the following conditions:  
 Cooling: Indoor temperature 27°C DB/19°C WB; Outdoor temperature 35°C DB/24°C WB; Heating: Indoor temperature 20°C DB/15°C WB; Outdoor temperature 7°C DB/6°C WB.  
 Piping length: Interconnecting piping length is 7.5m, level difference is zero.  
 Connection piping diameter of single-unit is the stop valve diameter of the unit.  
 Connection piping diameter of multi-unit is the main pipe connecting to the first indoor branch joint, in case of the total equivalent liquid length is less than 90m. If the total equivalent liquid length is more than 90m, please refer to technical manual to choose the connection piping diameter.  
 Sound values are measured in a semi-anechoic room, at a position 1m in front of the unit and 1.3m above the floor.

## VRF V4 Plus R Series - Heat Recovery



HP	58		60		62		64		
Model MDV-	1650(58)W/D2RN1T(C)		1700(60)W/D2RN1T(C)		1750(62)W/D2RN1T(C)		1800(64)W/D2RN1T(C)		
Combined type	14HPx3+16HP		14HPx2+16HPx2		14HP+16HPx3		16HPx4		
Power supply	V/Ph/Hz		380-415/3/50		380-415/3/50		380-415/3/50		
Cooling	Capacity	kW	165	170	175	180			
	Power input	kW	47.14	49.08	51.02	52.96			
	EER		3.5	3.46	3.43	3.4			
Heating	Capacity	kW	185	190	195	200			
	Power input	kW	46.36	47.96	49.56	51.16			
	COP		3.99	3.96	3.93	3.91			
Connectable indoor unit	Total capacity	50~130% of outdoor unit capacity							
	Max. quantity	64							
Compressor	Type	DC inverter							
	Quantity	8							
Fan motor	Type	DC motor							
	Quantity	8							
Refrigerant	Type	R410A							
	Factory charging	kg	13x4						
Pipe connections	Liquid pipe	mm	Φ22.2						
	Low pressure gas pipe	mm	Φ44.5						
	High pressure gas pipe	mm	Φ38.1						
	High pressure gas balance pipe	mm	Φ19.1						
	Oil balance pipe	mm	Φ6						
Air flow rate	m <sup>3</sup> /h	60000							
Sound pressure level	dB(A)	69							
Net dimension (WxHxD)	mm	(1250x1615x765)x4							
Packing size (WxHxD)	mm	(1305x1790x820)x4							
Net weight	kg	303x4							
Gross weight	kg	322x4							
Operating temperature range	°C	Cooling: -5~48; Heating: -20~24; Simultaneous Cooling and Heating: -5~24							

## VRF V4 Plus R Series - MS Box



Model	MS01/N1-C	MS02/N1-C	MS04/N1-C	MS06/N1-C	MS02E/N1-C	MS04E/N1-C			
Applicable indoor units	All VRF indoor units except high static pressure duct				Only high static pressure duct				
Max. indoor unit groups	1	2	4	6	1	1			
Max. number of each group of indoor units	4	4	4	4	1	1			
Max. number of downstream indoor units	4	8	16	24	1	1			
Max. capacity of each group of indoor units	kW		16	16	16	20/25/28	40/45/56		
Max. total capacity of all downstream indoor units	kW		16	28	45	45	20-28	40-56	
Piping connections	Connected to outdoor unit	Liquid pipe	mm	Φ9.53	Φ12.7	Φ15.9	Φ15.9	Φ12.7	Φ15.9
		High pressure gas pipe	mm	Φ15.9	Φ19.1	Φ22.2	Φ22.2	Φ19.1	Φ22.2
		Low pressure gas pipe	mm	Φ19.1	Φ25.4	Φ31.8	Φ31.8	Φ25.4	Φ31.8
	Connected to indoor unit	Liquid pipe	mm	Φ9.53	Φ9.53	Φ9.53	Φ9.53	Φ9.53	Φ9.53
Gas pipe		mm	Φ15.9	Φ15.9	Φ15.9	Φ15.9	Φ15.9	Φ15.9	
Sound pressure level	dB(A)		33	33	33	40	33	33	
Net dimension (WxHxD)	mm		630x225x600	630x225x600	960x225x600	960x225x600	630x225x600	960x225x600	
Packing size (WxHxD)	mm		725x325x685	725x325x685	1055x325x685	1055x325x685	725x325x685	1055x325x685	
Net weight	kg		18	19.5	31	35	19.5	31	
Gross weight	kg		25	27	40	44.5	27	40	

Note:  
 Sound values are measured in a semi-anechoic room, at a position 1m below the MS equipment in mode switch condition.  
 It is not recommended to install in a place where low noise performance is required.

**Indoor Units**

VRF V4 Plus indoor units

**Fresh Air Processing Unit**

100% fresh air supply

**Ventilation**

Heat recovery ventilator (HRV)

**AHU Connection Kit**

Connect to other brand AHU

**Control Systems**

Smart control systems



# VRF V4 Plus W Series Water Cooled

## Perfect combined of water and refrigerant system

- » DC inverter compressors
- » Capacity up to 36HP
- » Connectable indoor units quantity up to 59
- » Cycle duty operation
- » Backup operation
- » Precise oil control technology
- » Low noise operation
- » Simple communication wiring
- » Easy maintenance

### Wide Range of Outdoor Units »

The Water Cooled V4+W Series capacity ranges from 8HP to 36HP, meets all customer requirements from small to large buildings.

8/10/12HP

Max. 3 units combination



### Long Piping Length »

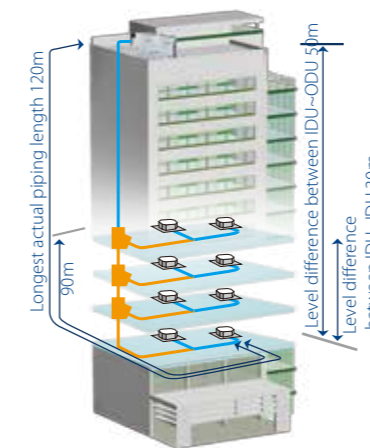

Total piping length	300m
Longest length actual (Equivalent)	120(150)m
Longest length after first branch	90*m
Level difference between indoor and outdoor units - ODU up (down)	50(40)m
Level difference between indoor units	30m

\*The longest piping length is 40m standard. It can be extended to 90m. When the length is over 40m, please contact your local Midea dealer for more information and restrictions.

### Wide Operation Temperature Range »

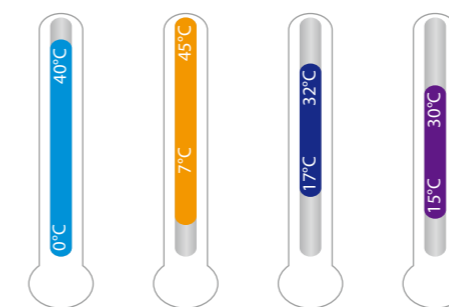

- Main unit ambient temperature: 0°C~40°C
- Main unit water inlet temperature: 7°C~45°C
- Indoor temperature in cooling mode: 17°C~32°C
- Indoor temperature in heating mode: 15°C~30°C

### High IPLV »

Midea V4 Plus W Series System combines water system and refrigerant system perfectly. IPLV(C) reaches as high as 5.9. Compared with air-cooled VRF, energy saving is higher.

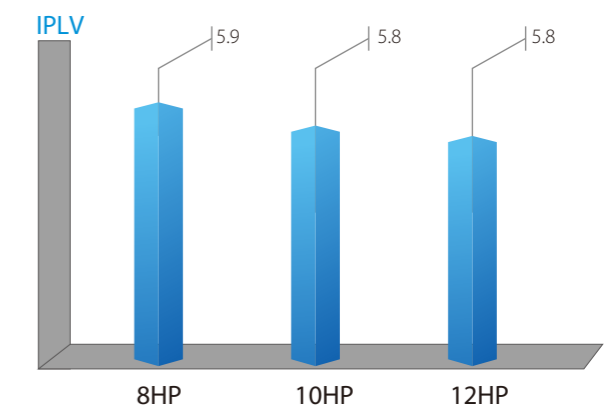



## High Efficiency Double-Pipe Heat Exchanger >>

With the innovatively designed double-pipe heat exchanger, the water quality required is low. The water side has large circulation area, and it is not easily plugged, creating higher reliability and easier cleaning and maintenance.



## Water Side Heat Recovery Function >>

In modern large-scale buildings, the load between the internal and external areas is different. It may occur in some situations that both cooling and heating are required. The V4 PLUS W Series not only can achieve meticulous system division in different areas but also can recover heat at the same time, significantly improving energy efficiency.

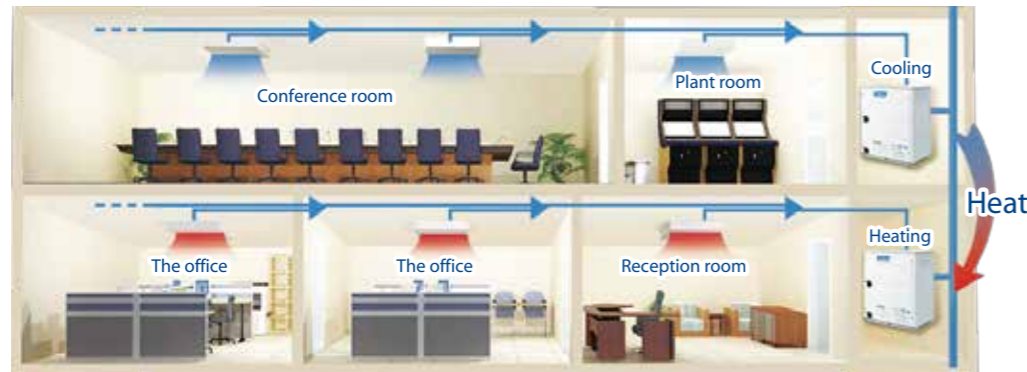

## No Water Leakage >>

No water pipes installed indoors, no water leakage risks.

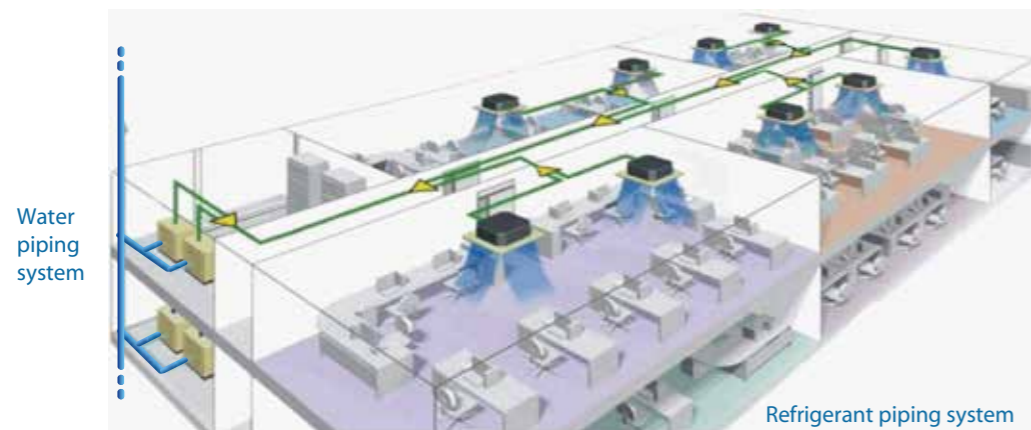

## VRF V4 Plus W Series - Water Cooled



HP			8	10	12	16	18	20	22
Model MDVS-			252(8)W/DRN1	280(10)W/DRN1	335(12)W/DRN1	504(16)W/DRN1	532(18)W/DRN1	560(20)W/DRN1	615(22)W/DRN1
Combined type			/	/	/	8HP×2	8HP+10HP	10HP×2	10HP+12HP
Power supply	V/Ph/Hz	380-415/3/50							
Cooling	Capacity	kW	25.2	28.0	33.5	50.4	53.2	56.0	61.5
	Power input	kW	4.80	6.10	8.00	9.60	10.90	12.20	14.10
	EER		5.25	4.59	4.19	5.25	4.88	4.59	4.36
Heating	Capacity	kW	27.0	31.5	37.5	54.0	58.5	63.0	69.0
	Power input	kW	4.45	5.83	7.80	8.90	10.3	11.66	13.63
	COP		6.07	5.40	4.81	6.07	5.69	5.40	5.06
Connectable indoor unit	Total capacity	50~130% of outdoor unit capacity							
	Max. quantity		13	16	19	23	29	33	36
Compressor	Type	DC inverter							
	Quantity		1	1	1	2	2	2	2
Heat exchanger	Type	Double-pipe heat exchanger							
	Rated water flow volume	m³/h	5.4	6	7.2	5.4×2	5.4+6	6×2	6+7.2
Refrigerant	Type	R410A							
	Factory charging	kg	2	2	2	2×2	2×2	2×2	2×2
Pipe connections	Liquid pipe	mm	Φ9.53	Φ9.53	Φ12.7	Φ12.7	Φ15.9	Φ15.9	Φ15.9
	Gas pipe	mm	Φ22.2	Φ22.2	Φ25.4	Φ28.6	Φ28.6	Φ28.6	Φ28.6
	Oil balance pipe	mm	Φ6.35	Φ6.35	Φ6.35	Φ6.35	Φ6.35	Φ6.35	Φ6.35
Sound pressure level	dB(A)	51	52	52	53	53	53	54	
Net dimension (W×H×D)	mm	780×1000×550			(780×1000×550)×2				
Packing size (W×H×D)	mm	845×1170×600			(845×1170×600)×2				
Net weight	kg	146	146	147	146×2	146×2	146×2	146+147	
Gross weight	kg	155	155	156	155×2	155×2	155×2	155+156	
Operating temperature range	°C	Water inlet temp.: 7-45; ambient temp.: 0-40							



HP			24	26	28	30	32	34	36
Model MDVS-			670(24)W/DRN1	784(26)W/DRN1	812(28)W/DRN1	840(30)W/DRN1	895(32)W/DRN1	950(34)W/DRN1	1005(36)W/DRN1
Combined type			12HP×2	8HP×2+10HP	8HP+10HP×2	10HP×3	10HP×2+12HP	10HP+12HP×2	12HP×3
Power supply	V/Ph/Hz	380-415/3/50							
Cooling	Capacity	kW	67.0	78.4	81.2	84.0	89.5	95.0	100.5
	Power input	kW	16.0	15.7	17.0	18.3	20.2	22.1	24.0
	EER		4.19	4.99	4.78	4.59	4.43	4.30	4.19
Heating	Capacity	kW	75.0	85.5	90.0	94.5	100.5	106.5	112.5
	Power input	kW	15.6	14.73	16.11	17.49	19.46	21.43	23.4
	COP		4.81	5.80	5.59	5.40	5.16	4.97	4.81
Connectable indoor unit	Total capacity	50~130% of outdoor unit capacity							
	Max. quantity		39	43	46	50	53	56	59
Compressor	Type	DC inverter							
	Quantity		2	3	3	3	3	3	3
Heat exchanger	Type	Double-pipe heat exchanger							
	Rated water flow volume	m³/h	7.2×2	5.4×2+6	5.4+6×2	6×3	6×2+7.2	6+7.2×2	7.2×3
Refrigerant	Type	R410A							
	Factory charging	kg	2×2	2×3	2×3	2×3	2×3	2×3	2×3
Pipe connections	Liquid pipe	mm	Φ15.9	Φ19.1	Φ19.1	Φ19.1	Φ19.1	Φ19.1	Φ19.1
	Gas pipe	mm	Φ28.6	Φ31.8	Φ31.8	Φ31.8	Φ31.8	Φ38.1	Φ38.1
	Oil balance pipe	mm	Φ6.35	Φ6.35	Φ6.35	Φ6.35	Φ6.35	Φ6.35	Φ6.35
Sound pressure level	dB(A)	54	55	55	56	57	57	58	
Net dimension (W×H×D)	mm	(780×1000×550)×2		(780×1000×550)×3					
Packing size (W×H×D)	mm	(845×1170×600)×2		(845×1170×600)×3					
Net weight	kg	147×2	146×3	146×3	146×3	146×2+147	146+147×2	147×3	
Gross weight	kg	156×2	155×3	155×3	155×3	155×2+156	155+156×2	156×3	
Operating temperature range	°C	Water inlet temp.: 7-45; ambient temp.: 0-40							

Notes:

Capacities are based on the following conditions:

Cooling: Indoor temperature 27°C DB/19°C WB; Main unit ambient temperature 35°C DB/24°C WB; Water inlet temperature 30°C;





Heating: Indoor temperature 20°C DB/15°C WB; Main unit ambient temperature 7°C DB/6°C WB; Water inlet temperature 20°C;

Piping length: Interconnecting piping length is 5m, level difference is zero.

Connection piping diameter of single-unit is the stop valve diameter of the unit.

Connection piping diameter of multi-unit is the main pipe connecting to the first indoor branch joint, in case of the total equivalent liquid length is less than 90m. If the total equivalent liquid length is more than 90m, please refer to technical manual to choose the connection piping diameter.

Sound values are measured in a semi-anechoic room, at a position 1m in front of the unit and 1m above the floor.

- 
**Indoor Units**  
 VRF V4 Plus indoor units
- 
**Fresh Air Processing Unit**  
 100% fresh air supply
- 
**Ventilation**  
 Heat recovery ventilator (HRV)
- 
**AHU Connection Kit**  
 Connect to other brand AHU
- 
**Control Systems**  
 Smart control systems



# VRF V4 Plus I Series Heat Pump

Optimized design  
for middle-sized  
buildings

- » DC inverter compressor
- » DC fan motor
- » Capacity up to 32HP
- » Connectable indoor units quantity up to 53
- » ESP up to 40Pa
- » Precise oil control technology
- » Advanced silence technology
- » Intelligent defrosting technology
- » Simple communication wiring
- » Auto addressing
- » Easy maintenance

## Long Piping Length »

	Side air discharge		Top air discharge		
	20-26kW	40-45kW	25.2-45kW	56-67kW	73-90kW
Total piping length	120m	250m	350m	1000m	1000m
Longest length actual (Equivalent)	60(70)m	100(120)m	150(175)m	175(200)m	165(190)m
Longest length after first branch	20m	40m	40m	90*m	90*m
Longest length after nearest branch	15m	15m	40m	40m	40m
Level difference between indoor and outdoor units - ODU up (down)	30(20)m	30(20)m	70(70)m	70(110)m	50(90)m
Level difference between indoor units	8m	8m	15m	30m	30m

\*The longest piping length is 40m standard. It can be extended to 90m. When the length is over 40m, please contact your local Midea dealer for more information and restrictions.

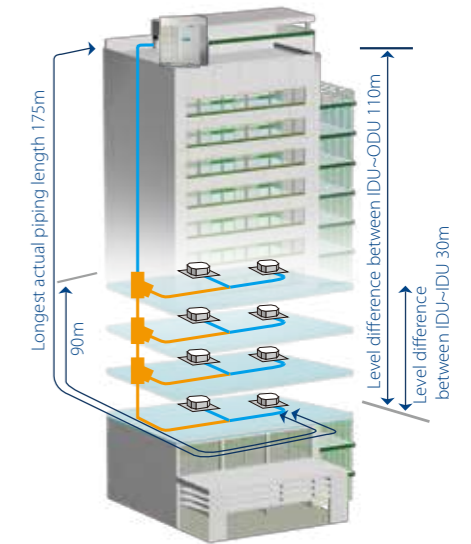

## Integrated Design, Easy Installation and Less Leakage Possibility »

- ❖ Compare with combination units, the individual units don't need complicated piping and wiring at the jobsite. It eliminates the communication wire, power wire, oil balance pipe, and refrigerant distributors between units.
- ❖ There are more brazing joints in the combination system, therefore vapor and moisture can easily enter the system. Thanks to reduced joints in the individual system, it minimizes the possibility of moisture entering the system.

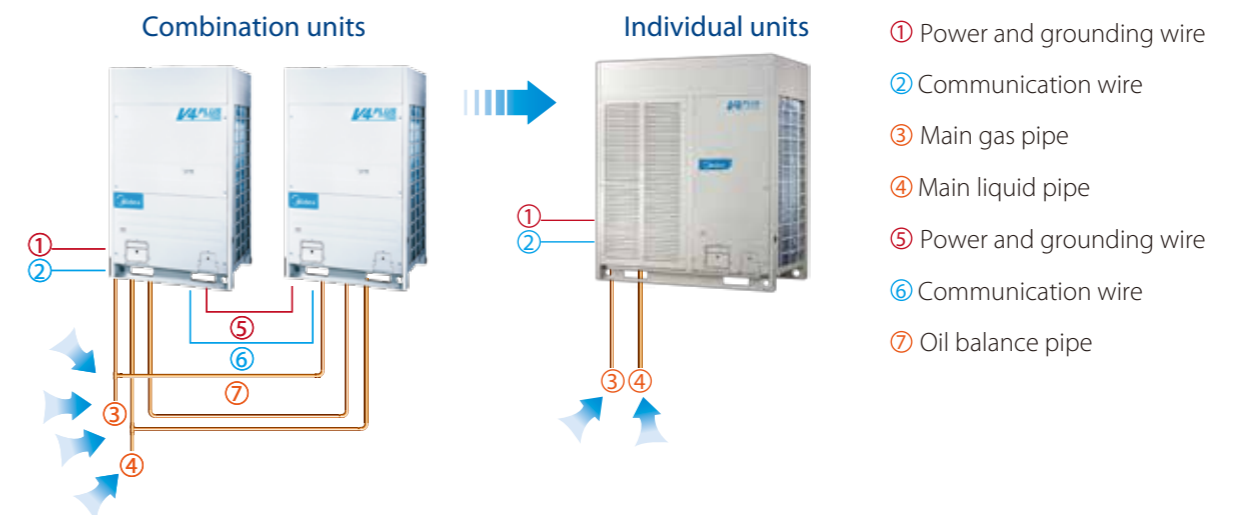



## VRF V4 Plus I Series - Heat Pump



HP			7	8	10	14	16
Model MDV-			V200W/DRN1	V224W/DRN1	V260W/DRN1	V400W/DRN1	V450W/DRN1
Power supply	V/Ph/Hz		380-415/3/50				
Cooling	Capacity	kW	20.0	22.4	26.0	40.0	45.0
	Power input	kW	6.1	6.8	7.6	11.9	13.6
	EER		3.28	3.29	3.42	3.35	3.32
Heating	Capacity	kW	22.0	24.5	28.5	45.0	50.0
	Power input	kW	6.1	5.9	6.8	11.1	12.7
	COP		3.61	4.15	4.19	4.05	3.93
Connectable indoor unit	Total capacity	50~130% of outdoor unit capacity					
	Max. quantity		10	11	12	14	15
Compressor	Type	DC inverter					
	Quantity		1	1	1	2	2
Fan motor	Type	DC motor			DC motor+AC motor		
	Quantity		2	2	2	2	2
Refrigerant	Type	R410A					
	Factory charging	kg	4.8	6.2	6.2	9	12
Pipe connections	Liquid pipe	mm	Φ9.53	Φ9.53	Φ9.53	Φ12.7	Φ12.7
	Gas pipe	mm	Φ19.1	Φ19.1	Φ22.2	Φ22.2	Φ25.4
Air flow rate		m³/h	10999	10494	10494	16575	16575
Sound pressure level		dB(A)	59	59	60	62	62
Net dimension (WxHxD)		mm	1120x1558x528			1360x1650x540	1460x1650x540
Packing size (WxHxD)		mm	1270x1720x565			1450x1785x560	1550x1785x560
Net weight		kg	137	146.5	147	240	275
Gross weight		kg	153	162.5	163	260	290
Operating temperature range		°C	Cooling: -15~46; Heating: -15~24			Cooling: -5~48; Heating: -15~24	



HP			8	10	12	14
Model MDV-			252W/DRN1-i(B)	280W/DRN1-i(B)	335W/DRN1-i(B)	400W/DRN1-i(B)
Power supply	V/Ph/Hz		380-415/3/50			
Cooling	Capacity	kW	25.2	28.0	33.5	40.0
	Power input	kW	5.9	7.2	9.1	12.3
	EER		4.29	3.89	3.7	3.25
Heating	Capacity	kW	27.0	31.5	37.5	45.0
	Power input	kW	6.2	7.6	9.0	11.2
	COP		4.39	4.14	4.17	4.02
Connectable indoor unit	Total capacity	50~130% of outdoor unit capacity				
	Max. quantity		13	16	16	16
Compressor	Type	DC inverter			DC inverter+Fixed	
	Quantity		1	1	2	3
Fan motor	Type	DC motor				
	Quantity		1	1	2	2
Max Static Pressure	Pa	20 (default)				
	Pa	40 (customized)				
Refrigerant	Type	R410A				
	Factory charging	kg	10	10	12	15
Pipe connections	Liquid pipe	mm	Φ12.7	Φ12.7	Φ15.9	Φ15.9
	Gas pipe	mm	Φ25.4	Φ25.4	Φ31.8	Φ31.8
Air flow rate		m³/h	11000	11000	15000	15000
Sound pressure level		dB(A)	57	57	58	60
Net dimension (WxHxD)		mm	960x1615x765		1250x1615x765	
Packing size (WxHxD)		mm	1025x1790x830		1305x1790x820	
Net weight		kg	205		275	325
Gross weight		kg	220		295	345
Operating temperature range		°C	Cooling: -5~48; Heating: -15~24			

Notes:  
 Capacities are based on the following conditions:  
 Cooling: Indoor temperature 27°C DB/19°C WB; Outdoor temperature 35°C DB/24°C WB; Heating: Indoor temperature 20°C DB/15°C WB; Outdoor temperature 7°C DB/6°C WB.  
 Piping length: Interconnecting piping length is 7.5m, level difference is zero.  
 Sound values are measured in a semi-anechoic room, at a position 1m in front of the unit and 1.3m above the floor.

## VRF V4 Plus I Series - Heat Pump



HP			16	20	22	24
Model MDV-			450W/DRN1-i(B)	560W/DRN1-i(C)	615W/DRN1-i(C)	670W/DRN1-i(C)
Power supply	V/Ph/Hz		380-415/3/50			
Cooling	Capacity	kW	45.0	56.0	61.5	67.0
	Power input	kW	14	17	18.8	20.8
	EER		3.21	3.3	3.27	3.22
Heating	Capacity	kW	50.0	63.0	69.0	75.0
	Power input	kW	12.8	16	17.9	19.8
	COP		3.91	3.94	3.86	3.79
Connectable indoor unit	Total capacity	50~130% of outdoor unit capacity				
	Max. quantity		20	33	36	39
Compressor	Type	DC inverter+Fixed				
	Quantity		3	3	3	3
Fan motor	Type	DC motor			DC motor+AC motor	
	Quantity		2	2	2	2
Max Static Pressure	Pa	20 (default)				
	Pa	40 (customized)				
Refrigerant	Type	R410A				
	Factory charging	kg	15	17	18.5	18.5
Pipe connections	Liquid pipe	mm	Φ15.9	Φ19.1	Φ19.1	Φ19.1
	Gas pipe	mm	Φ31.8	Φ31.8	Φ31.8	Φ31.8
Air flow rate		m³/h	15000	20000	23000	23000
Sound pressure level		dB(A)	60	62	63	63
Net dimension (WxHxD)		mm	1250x1615x765	1390x1615x765		
Packing size (WxHxD)		mm	1305x1790x820	1455x1790x830		1585x1615x765 1650x1810x840
Net weight		kg	325	360	385	390
Gross weight		kg	345	375	400	405
Operating temperature range		°C	Cooling: -5~48; Heating: -15~24			



HP			26	28	30	32
Model MDV-			730W/DRN1-i(C)	785W/DRN1-i(C)	850W/DRN1-i(C)	900W/DRN1-i(C)
Power supply	V/Ph/Hz		380-415/3/50			
Cooling	Capacity	kW	73.0	78.5	85.0	90.0
	Power input	kW	22.3	24.2	28.3	28.5
	EER		3.27	3.24	3	3.16
Heating	Capacity	kW	81.5	87.5	95.0	100.0
	Power input	kW	20.6	22.4	26.0	26.5
	COP		3.96	3.91	3.65	3.77
Connectable indoor unit	Total capacity	50~130% of outdoor unit capacity				
	Max. quantity		43	46	50	53
Compressor	Type	DC inverter+Fixed				
	Quantity		3	3	4	5
Fan motor	Type	AC motor				
	Quantity		4	4	4	4
Max Static Pressure	Pa	20 (default)				
	Pa	40 (customized)				
Refrigerant	Type	R410A				
	Factory charging	kg	27	27	27	27
Pipe connections	Liquid pipe	mm	Φ22.2	Φ22.2	Φ22.2	Φ22.2
	Gas pipe	mm	Φ38.1	Φ38.1	Φ38.1	Φ38.1
Air flow rate		m³/h	33100	33100	33100	33100
Sound pressure level		dB(A)	64	64	65	65
Net dimension (WxHxD)		mm	2540x1615x765			
Packing size (WxHxD)		mm	2600x1800x825			
Net weight		kg	555		600	
Gross weight		kg	590		635	
Operating temperature range		°C	Cooling: -5~48; Heating: -15~24			

Notes:  
 Capacities are based on the following conditions:  
 Cooling: Indoor temperature 27°C DB/19°C WB; Outdoor temperature 35°C DB/24°C WB; Heating: Indoor temperature 20°C DB/15°C WB; Outdoor temperature 7°C DB/6°C WB.  
 Piping length: Interconnecting piping length is 7.5m, level difference is zero.  
 Sound values are measured in a semi-anechoic room, at a position 1m in front of the unit and 1.3m above the floor.

**Indoor Units**  
VRF V4 Plus indoor units

**Ventilation**  
Heat recovery ventilator (HRV)

**Control Systems**  
Smart control systems



# VRF V4 Plus Mini Series Heat Pump

Optimized design for small buildings

- » DC inverter compressor
- » DC fan motor
- » Capacity up to 18kW
- » Connectable indoor units quantity up to 9
- » Precise oil control technology
- » Advanced silence technology
- » Intelligent defrosting technology
- » Simple communication wiring
- » Auto addressing
- » Easy maintenance

## Long Piping Length »

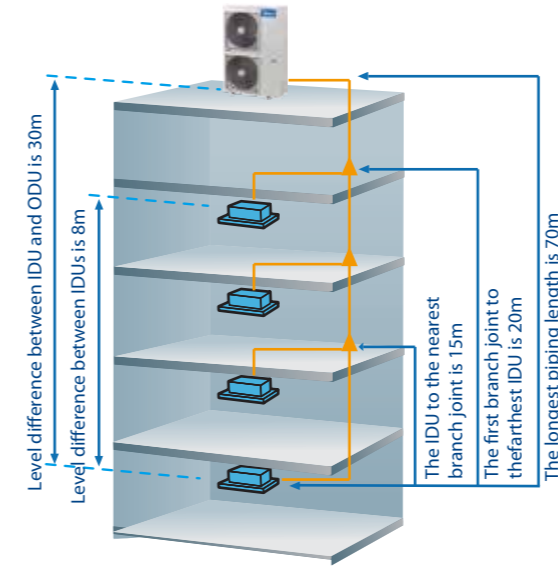

	8-10.5kW	12-18kW
Total piping length	100m	100m
Longest length actual (Equivalent)	45(50)m	60(70)m
Longest length after first branch	20m	20m
Level difference between indoor and outdoor units - ODU up (down)	30(20)m	30(20)m
Level difference between indoor units	8m	8m

## More Convenient Piping Connector – Branch Box »

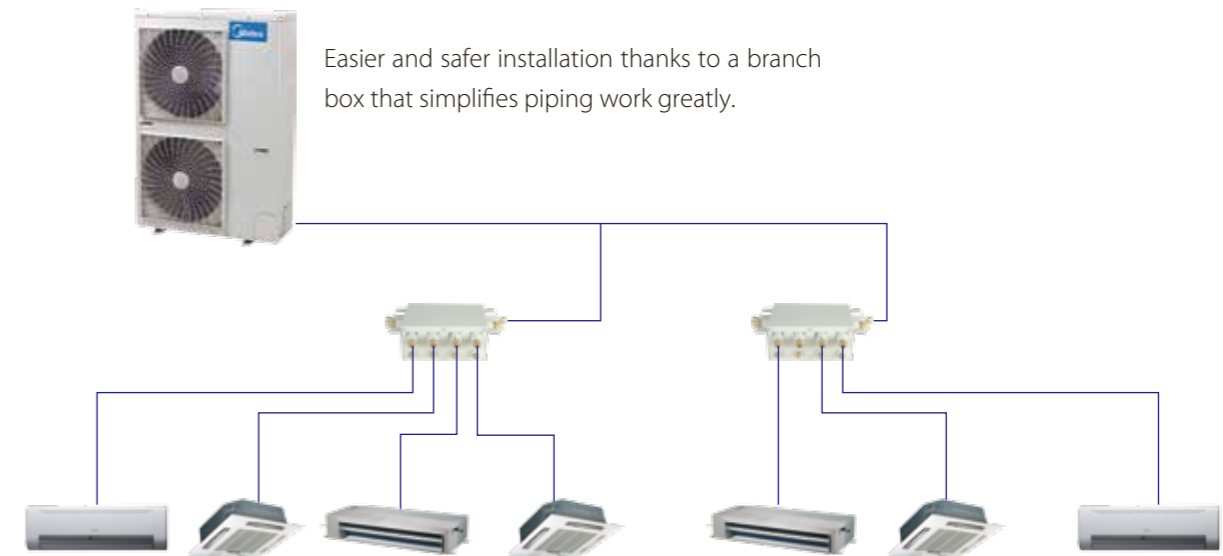

## Four-Way Piping Connection »

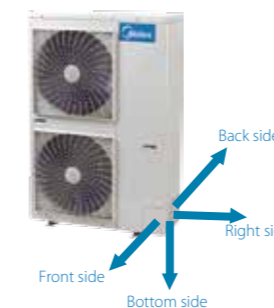

A four-direction space is available for connecting pipes and wiring in various installation sites.



## VRF V4 Plus Mini Series - Heat Pump



HP			3	4	4.5	5	6
Model MDV-			V80W/DN1	V105W/DN1	V120W/DN1	V140W/DN1	V160W/DN1(B)
Power supply	V/Ph/Hz	220-240/1/50					
Cooling	Capacity	kW	7.2 (1.5~8.0)	9.0 (2.0~10.0)	12.3	14	15.5
	Power input	kW	1.85	2.30	3.25	3.95	4.52
	EER		3.9	3.92	3.78	3.54	3.43
Heating	Capacity	kW	7.2 (1.6~8.4)	9.0 (2.1~10.5)	13.2	15.4	17
	Power input	kW	1.79	2.27	3.47	4.16	4.78
	COP		4.02	3.97	3.8	3.7	3.56
Connectable indoor unit	Total capacity	45~130% of outdoor unit capacity					
	Max. quantity		4	5	6	6	7
Compressor	Type	Rotary					
	Quantity		1	1	1	1	1
Fan motor	Type	DC Motor					
	Quantity		1	1	2	2	2
Refrigerant	Type	R410A					
	Factory charging	kg	2.95	2.95	3.3	3.9	3.9
Pipe connections	Liquid pipe	mm	Φ9.53	Φ9.53	Φ9.53	Φ9.53	Φ9.53
	Gas pipe	mm	Φ15.9	Φ15.9	Φ15.9	Φ15.9	Φ19.1
Air flow rate	m³/h	5500	5500	6000	6000	6000	
Sound pressure level	dB(A)	56	57	57	57	57	
Net dimension (WxHxD)	mm	1075x966x396			900x1327x400		
Packing size (WxHxD)	mm	1120x1100x435			1030x1456x435		
Net weight	kg	75.5	75.5	95		100	
Gross weight	kg	85.5	85.5	106		111	
Operating temperature range	°C	Cooling: -15~43; Heating: -15~27					

Notes:  
 Capacities are based on the following conditions:  
 Cooling: Indoor temperature 27°C DB/19°C WB; Outdoor temperature 35°C DB/24°C WB; Heating: Indoor temperature 20°C DB/15°C WB; Outdoor temperature 7°C DB/6°C WB.  
 Piping length: Interconnecting piping length is 7.5m, level difference is zero.  
 Sound values are measured in a semi-anechoic room, at a position 1m in front of the unit and 1m above the floor.

## VRF V4 Plus Mini Series - Heat Pump



HP			4.5	5	6	6.5
Model MDV-			V120W/DRN1	V140W/DRN1	V160W/DRN1	V180W/DRN1
Power supply	V/Ph/Hz	380-415/3/50				
Cooling	Capacity	kW	12.3	14	15.5	17.5
	Power input	kW	3.25	3.95	4.52	5.3
	EER		3.78	3.54	3.43	3.3
Heating	Capacity	kW	13.2	15.4	17	19
	Power input	kW	3.47	4.16	4.78	5
	COP		3.8	3.7	3.56	3.8
Connectable indoor unit	Total capacity	45~130% of outdoor unit capacity				
	Max. quantity		6	6	7	9
Compressor	Type	Rotary				
	Quantity		1	1	1	1
Fan motor	Type	DC motor				
	Quantity		2	2	2	2
Refrigerant	Type	R410A				
	Factory charging	kg	3.3	3.9	3.9	4.5
Pipe connections	Liquid pipe	mm	Φ9.53	Φ9.53	Φ9.53	Φ9.53
	Gas pipe	mm	Φ15.9	Φ15.9	Φ19.1	Φ19.1
Air flow rate	m³/h	6000	6000	6000	6800	
Sound pressure level	dB(A)	57	57	57	59	
Net dimension (WxHxD)	mm	900x1327x400				
Packing size (WxHxD)	mm	1030x1456x435				
Net weight	kg	95		102		107
Gross weight	kg	106		113		118
Operating temperature range	°C	Cooling: -15~43; Heating: -15~27				

Notes:  
 Capacities are based on the following conditions:  
 Cooling: Indoor temperature 27°C DB/19°C WB; Outdoor temperature 35°C DB/24°C WB; Heating: Indoor temperature 20°C DB/15°C WB; Outdoor temperature 7°C DB/6°C WB.  
 Piping length: Interconnecting piping length is 7.5m, level difference is zero.  
 Sound values are measured in a semi-anechoic room, at a position 1m in front of the unit and 1m above the floor.



INDOOR UNITS

INDOOR UNITS

## » INDOOR UNITS

- One-way Cassette
- Two-way Cassette
- Compact Four-way Cassette
- Four-way Cassette
- Low Static Pressure Duct
- Medium Static Pressure Duct (A5 type)

- High Static Pressure Duct
- Fresh Air Processing Unit
- Console
- Wall-mounted
- Ceiling & Floor
- Floor Standing

# Cassette Series



One-way Cassette



Two-way Cassette



Compact Four-way Cassette



Four-way Cassette



- Auto Restart Function
- Auto Addressing
- Fresh Air
- Auto Defrosting
- Easy-cleaning Panel
- Follow Me
- Anti-cold Air Function
- Built-in Drain Pump
- LED Display
- Built-in Filter
- Independent Dehumidification
- Timer
- Auto Swing
- Wired Controller

## One-way Cassette

### Min. 153mm Thickness >>

Compact design, ultra slim body with a minimum thickness of 153mm for models 18-36 and 189mm for models 45-71, especially suitable for narrow ceiling, such as in lobbies and small meeting rooms.

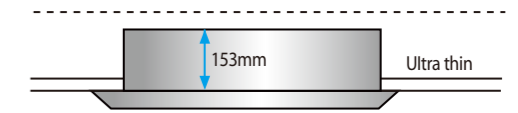

### High-lift Pump >>

Standard built-in drain pump with 750mm pumphead.

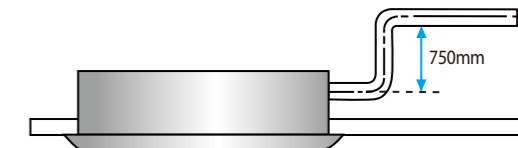

### Fresh Air, Improved Air Quality >>

Reserved fresh air intake port for high quality air creates a comfortable and healthy environment (for models 45-71).



## Specifications

Model		MDV-D18Q1/N1-D	MDV-D22Q1/N1-D	MDV-D28Q1/N1-D	MDV-D36Q1/N1-D	MDV-D45Q1/N1-D	MDV-D56Q1/N1-D	MDV-D71Q1/N1-D	
Power supply		1-phase,220-240V,50Hz							
Capacity	Cooling	kW	1.8	2.2	2.8	3.6	4.5	5.6	7.1
	Heating	kW	2.2	2.6	3.2	4.0	5.0	6.3	8.0
Power input	Cooling	W	41	41	41	41	48	48	60
	Heating	W	41	41	41	41	43	44	55
Airflow rate(H/M/L)	m <sup>3</sup> /h	523/404/275	523/404/275	573/456/315	573/456/315	693/600/476	792/688/549	933/749/592	
Sound pressure level(H/M/L)	dB(A)	37/34/30	38/34/30	39/37/34	40/38/34	41/39/35	42/40/36	44/41/37	
Main body	Net dim.(W×H×D)	mm	1054×153×425	1054×153×425	1054×153×425	1054×153×425	1275×189×450	1275×189×450	1275×189×450
	Packing dim.(W×H×D)	mm	1155×245×490	1155×245×490	1155×245×490	1155×245×490	1370×295×505	1370×295×505	1370×295×505
	Net/gross weight	kg	12.5/16	12.5/16	13/16.5	13/16.5	18.5/22.8	18.8/23.1	19.5/23.8
Panel	Net dim.(W×H×D)	mm	1180×25×465	1180×25×465	1180×25×465	1180×25×465	1350×25×505	1350×25×505	1350×25×505
	Packing dim.(W×H×D)	mm	1232×107×517	1232×107×517	1232×107×517	1232×107×517	1410×95×560	1410×95×560	1410×95×560
	Net/gross weight	kg	3.5/5.2	3.5/5.2	3.5/5.2	3.5/5.2	4/5.4	4/5.4	4/5.4
Piping connections	Liquid/gas pipe	mm	Φ6.35/Φ12.7	Φ6.35/Φ12.7	Φ6.35/Φ12.7	Φ6.35/Φ12.7	Φ6.35/Φ12.7	Φ9.53/Φ15.9	Φ9.53/Φ15.9
	Drain pipe	mm	OD Φ25	OD Φ25	OD Φ25	OD Φ25	OD Φ25	OD Φ25	OD Φ25
Standard controller		Wireless remote controller							

Notes:

- Nominal cooling capacities are based on the following conditions: return air temperature: 27°CDB, 19°CWB, outdoor temperature: 35°CDB, equivalent ref. piping: 7.5m(horizontal).
- Nominal heating capacities are based on the following conditions: return air temperature: 20°CDB, outdoor temperature: 7°CDB, 6°CWB, equivalent ref. piping: 7.5m(horizontal).
- Sound level is measured at 1.4m below the unit.



## Two-way Cassette

### Quiet Operation >>

Optimized airflow duct with low resistance greatly reduces noise, down to a minimum of 24dB(A).

### High-lift Pump >>

Standard built-in drain pump with 750mm pump head (higher pump head can be customized).

### Stylish Design and Slim Body >>

Thanks to the stylish appearance and slim body, the unit suits any room's decor and ambience. At only 300mm high, the unit requires only a small space in suspended ceilings. Installation has no height limitations, which means overall design features much more flexibility.

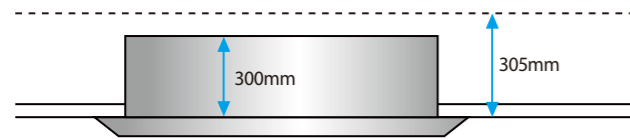

### High Airflow >>

High airflow for high ceiling application guarantees comfort in large spaces. Guarantees even airflow and temperature throughout the room.



## Specifications

Model			MDV-D22Q2/N1	MDV-D28Q2/N1	MDV-D36Q2/N1	MDV-D45Q2/N1	MDV-D56Q2/N1	MDV-D71Q2/N1
Power supply			1-phase,220-240V,50Hz					
Capacity	Cooling	kW	2.2	2.8	3.6	4.5	5.6	7.1
	Heating	kW	2.6	3.2	4.0	5.0	6.3	8.0
Power input	Cooling	W	57	57	60	92	108	154
	Heating	W	57	57	60	92	108	154
Airflow rate(H/W/L)		m³/h	654/530/410	654/530/410	725/591/458	850/670/550	980/800/670	1,200/1,000/770
Sound pressure level(H/W/L)		dB(A)	33/29/24	36/32/29	36/32/29	39/35/30	39/35/30	44/40/34
Main body	Net dim.(W×H×D)	mm	1172×299×591	1172×299×591	1172×299×591	1172×299×591	1172×299×591	1172×299×591
	Packing dim.(W×H×D)	mm	1355×400×675	1355×400×675	1355×400×675	1355×400×675	1355×400×675	1355×400×675
	Net/gross weight	kg	34/42.5	34/42.5	34/42.5	36/44.5	36/44.5	36/44.5
Panel	Net dim.(W×H×D)	mm	1430×53×680	1430×53×680	1430×53×680	1430×53×680	1430×53×680	1430×53×680
	Packing dim.(W×H×D)	mm	1525×130×765	1525×130×765	1525×130×765	1525×130×765	1525×130×765	1525×130×765
	Net/gross weight	kg	10.5/15	10.5/15	10.5/15	10.5/15	10.5/15	10.5/15
Piping connections	Liquid/gas pipe	mm	Φ6.35/Φ12.7	Φ6.35/Φ12.7	Φ6.35/Φ12.7	Φ6.35/Φ12.7	Φ9.53/Φ15.9	Φ9.53/Φ15.9
	Drain pipe	mm	OD Φ32	OD Φ32	OD Φ32	OD Φ32	OD Φ32	OD Φ32
Standard controller			Wireless remote controller					

Notes:

- Nominal cooling capacities are based on the following conditions: return air temperature: 27°CDB, 19°CWB, outdoor temperature: 35°CDB, equivalent ref. piping: 7.5m(horizontal).
- Nominal heating capacities are based on the following conditions: return air temperature: 20°CDB, outdoor temperature: 7°CDB, 6°CWB, equivalent ref. piping: 7.5m(horizontal).
- Sound level is measured at 1.4m below the unit.

## Four-way Cassette

### Various Selections >>

Three selections: Compact Four-way Cassette, Four-way Cassette& Four-way Cassette Silent Type.

### Flexible Air Distribution Type >>

7 discharge patterns in 2 to 4 directions can be selected to suit the requirements of the installation site or the shape of the room.

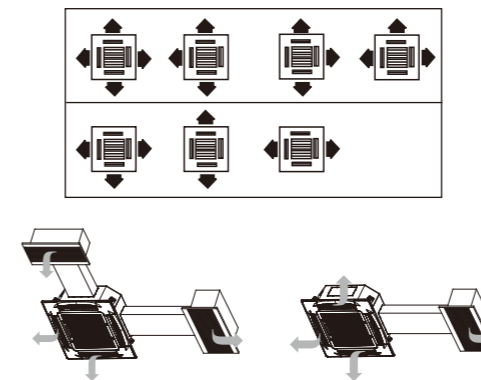

Duct connection is possible

### Compact Design, Easy Installation >>

For Compact Four-way Cassette: Extremely compact casing suits any room's decor and requires little space for installation on a low ceiling. Due to compact body and light weight, all models can be installed without a hoist.

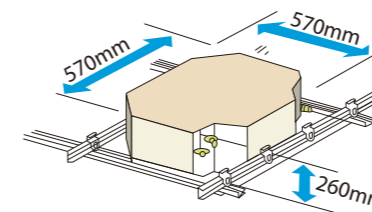

### 360° Airflow Outlet >>

For Compact Four-way Cassette: 360° air outlet provides strong air flow circulation to cool or heat every corner of a room and evenly control temperatures.



### Sub Duct >>

Sub duct enables you to use the same air conditioner unit to cool an additional smaller space nearby.

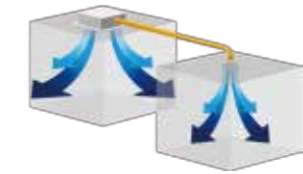

### Fresh Air Intake >>

Fresh air can enter through the cassette unit so you can enjoy even fresher air in a room.



### Easy Troubleshooting >>

For Four-way Cassette& Four-way Cassette Silent Type: By adding digital tube on the display board, Error Codes can be displayed directly for troubleshooting.



### Lower Operating Noise >>

For Four-way Cassette Silent Type: The newly designed fan blade, air deflector and the built-in throttling part reduce noise greatly.



### High-lift Drain Pump >>

For Compact Four-way Cassette: Drain pump with a 500mm pump head is fitted as standard; maximum 600mm pump head is available.

For Four-way Cassette& Four-way Cassette Silent Type: Drain pump can pump condenser water up to 750mm high, which simplifies installation of the drain piping system.

## Compact Four-way Cassette

Model			MDV-D15Q4/N1-A3	MDV-D22Q4/N1-A3	MDV-D28Q4/N1-A3	MDV-D36Q4/N1-A3	MDV-D45Q4/N1-A3
Power supply			1-phase,220-240V,50Hz				
Capacity	Cooling	kW	1.5	2.2	2.8	3.6	4.5
	Heating	kW	1.7	2.4	3.2	4.0	5.0
Power input	Cooling	W	36	50	50	56	56
	Heating	W	36	50	50	56	56
Airflow rate(H/M/L)	m <sup>3</sup> /h		435/283/208	414/313/238	414/313/238	521/409/314	521/409/314
Sound pressure level(H/M/L)	dB(A)		34.9/32.5/22.5	35.8/33.4/23.4	35.8/33.4/23.4	41.5/35.6/28.8	41.5/35.6/28.8
Main body	Net dim.(WxHxD)	mm	570x260x570	570x260x570	570x260x570	570x260x570	570x260x570
	Packing dim.(WxHxD)	mm	675x285x675	675x285x675	675x285x675	675x285x675	675x285x675
	Net/gross weight	kg	16/19.5	16/20	16/20	18/22	18/22
Panel	Net dim.(WxHxD)	mm	647x50x647	647x50x647	647x50x647	647x50x647	647x50x647
	Packing dim.(WxHxD)	mm	715x123x715	715x123x715	715x123x715	715x123x715	715x123x715
	Net/gross weight	kg	2.5/4.5	2.5/4.5	2.5/4.5	2.5/4.5	2.5/4.5
Piping connections	Liquid/gas pipe	mm	Φ6.35/Φ12.7	Φ6.35/Φ12.7	Φ6.35/Φ12.7	Φ6.35/Φ12.7	Φ6.35/Φ12.7
	Drain pipe	mm	OD Φ25	OD Φ25	OD Φ25	OD Φ25	OD Φ25
Standard controller			Wireless remote controller				

## Four-way Cassette

Model			MDV-D28Q4/N1-D	MDV-D36Q4/N1-D	MDV-D45Q4/N1-D	MDV-D56Q4/N1-D	MDV-D71Q4/N1-D
Power supply			1-phase,220-240V,50Hz				
Capacity	Cooling	kW	2.8	3.6	4.5	5.6	7.1
	Heating	kW	3.2	4.0	5.0	6.3	8.0
Power input	Cooling	W	65	65	75	75	82
	Heating	W	65	65	75	75	82
Airflow rate(H/M/L)	m <sup>3</sup> /h		847/766/640	847/766/640	864/755/658	864/755/658	1,157/955/749
Sound pressure level(H/M/L)	dB(A)		42/38/35	42/38/35	42/38/35	42/38/35	45/42/39
Main body	Net dim.(WxHxD)	mm	904x230x840	904x230x840	904x230x840	904x230x840	904x230x840
	Packing dim.(WxHxD)	mm	955x260x955	955x260x955	955x260x955	955x260x955	955x260x955
	Net/gross weight	kg	24/28	24/28	26/30	26/30	26/30
Panel	Net dim.(WxHxD)	mm	950x54.5x950	950x54.5x950	950x54.5x950	950x54.5x950	950x54.5x950
	Packing dim.(WxHxD)	mm	1035x90x1035	1035x90x1035	1035x90x1035	1035x90x1035	1035x90x1035
	Net/gross weight	kg	6/9	6/9	6/9	6/9	6/9
Piping connections	Liquid/gas pipe	mm	Φ6.35/Φ12.7	Φ6.35/Φ12.7	Φ6.35/Φ12.7	Φ9.53/Φ15.9	Φ9.53/Φ15.9
	Drain pipe	mm	OD Φ32	OD Φ32	OD Φ32	OD Φ32	OD Φ32
Standard controller			Wireless remote controller				

Model			MDV-D80Q4/N1-D	MDV-D90Q4/N1-D	MDV-D100Q4/N1-D	MDV-D112Q4/N1-D	MDV-D140Q4/N1-D
Power supply			1-phase,220-240V,50Hz				
Capacity	Cooling	kW	8.0	9.0	10.0	11.2	14.0
	Heating	kW	9.0	10.0	11.1	12.5	15.0
Power input	Cooling	W	97	160	160	160	170
	Heating	W	97	160	160	160	170
Airflow rate(H/M/L)	m <sup>3</sup> /h		1236/973/729	1540/1300/1120	1540/1300/1120	1540/1300/1120	1800/1500/1280
Sound pressure level(H/M/L)	dB(A)		45/42/39	48/45/43	48/45/43	48/45/43	50/47/44
Main body	Net dim.(WxHxD)	mm	904x230x840	904x300x840	904x300x840	904x300x840	904x300x840
	Packing dim.(WxHxD)	mm	955x260x955	955x330x955	955x330x955	955x330x955	955x330x955
	Net/gross weight	kg	26/30	32/37	32/37	32/37	32/37
Panel	Net dim.(WxHxD)	mm	950x54.5x950	950x54.5x950	950x54.5x950	950x54.5x950	950x54.5x950
	Packing dim.(WxHxD)	mm	1035x90x1035	1035x90x1035	1035x90x1035	1035x90x1035	1035x90x1035
	Net/gross weight	kg	6/9	6/9	6/9	6/9	6/9
Piping connections	Liquid/gas pipe	mm	Φ9.53/Φ15.9	Φ9.53/Φ15.9	Φ9.53/Φ15.9	Φ9.53/Φ15.9	Φ9.53/Φ15.9
	Drain pipe	mm	OD Φ32	OD Φ32	OD Φ32	OD Φ32	OD Φ32
Standard controller			Wireless remote controller				

## Four-way Cassette Silent Type

Model			MDV-D28Q4/N1-E	MDV-D36Q4/N1-E	MDV-D45Q4/N1-E	MDV-D56Q4/N1-E	MDV-D71Q4/N1-E
Power supply			1-phase,220-240V,50Hz				
Capacity	Cooling	kW	2.8	3.6	4.5	5.6	7.1
	Heating	kW	3.2	4.0	5.0	6.3	8.0
Power input	Cooling	W	80	80	88	88	88
	Heating	W	80	80	88	88	88
Airflow rate(H/M/L)	m <sup>3</sup> /h		764/638//554	764/638//554	905/740//651	905/740//651	950/767//663
Sound pressure level(H/M/L)	dB(A)		32/31/30	32/31/30	36/34/33	36/34/33	38/36/35
Main body	Net dim.(WxHxD)	mm	840x230x840	840x230x840	840x230x840	840x230x840	840x230x840
	Packing dim.(WxHxD)	mm	955x260x955	955x260x955	955x260x955	955x260x955	955x260x955
	Net/gross weight	kg	21.5/26.7	21.5/26.7	23.7/28.9	23.7/28.9	23.7/28.9
Panel	Net dim.(WxHxD)	mm	950x54.5x950	950x54.5x950	950x54.5x950	950x54.5x950	950x54.5x950
	Packing dim.(WxHxD)	mm	1035x90x1035	1035x90x1035	1035x90x1035	1035x90x1035	1035x90x1035
	Net/gross weight	kg	6/9	6/9	6/9	6/9	6/9
Piping connections	Liquid/gas pipe	mm	Φ6.35/Φ12.7	Φ6.35/Φ12.7	Φ6.35/Φ12.7	Φ9.53/Φ15.9	Φ9.53/Φ15.9
	Drain pipe	mm	OD Φ32	OD Φ32	OD Φ32	OD Φ32	OD Φ32
Standard controller			Wireless remote controller				

Model			MDV-D80Q4/N1-E	MDV-D90Q4/N1-E	MDV-D100Q4/N1-E	MDV-D112Q4/N1-E	MDV-D140Q4/N1-E
Power supply			1-phase,220-240V,50Hz				
Capacity	Cooling	kW	8.0	9.0	10.0	11.2	14.0
	Heating	kW	9.0	10.0	11.1	12.5	15.0
Power input	Cooling	W	110	140	165	165	176
	Heating	W	110	140	165	165	176
Airflow rate(H/M/L)	m <sup>3</sup> /h		1200/1021/789	1332/1129/908	1651/1304/1127	1651/1304/1127	1658/1335/1130
Sound pressure level(H/M/L)	dB(A)		42/39/37	43/39/38	45/42/40	45/42/40	46/41/39
Main body	Net dim.(WxHxD)	mm	840x230x840	840x300x840	840x300x840	840x300x840	840x300x840
	Packing dim.(WxHxD)	mm	955x260x955	955x330x955	955x330x955	955x330x955	955x330x955
	Net/gross weight	kg	23.7/28.9	28.7/34.1	28.7/34.1	28.7/34.1	30.9/36.3
Panel	Net dim.(WxHxD)	mm	950x54.5x950	950x54.5x950	950x54.5x950	950x54.5x950	950x54.5x950
	Packing dim.(WxHxD)	mm	1035x90x1035	1035x90x1035	1035x90x1035	1035x90x1035	1035x90x1035
	Net/gross weight	kg	6/9	6/9	6/9	6/9	6/9
Piping connections	Liquid/gas pipe	mm	Φ9.53/Φ15.9	Φ9.53/Φ15.9	Φ9.53/Φ15.9	Φ9.53/Φ15.9	Φ9.53/Φ15.9
	Drain pipe	mm	OD Φ32	OD Φ32	OD Φ32	OD Φ32	OD Φ32
Standard controller			Wireless remote controller				

Notes:

- Nominal cooling capacities are based on the following conditions: return air temperature: 27°CDB, 19°CWB, outdoor temperature: 35°CDB, equivalent ref. piping: 7.5m(horizontal).
- Nominal heating capacities are based on the following conditions: return air temperature: 20°CDB, outdoor temperature: 7°CDB, 6°CWB, equivalent ref. piping: 7.5m(horizontal).
- Sound level is measured at 1.4m below the unit.



# Duct series

INDOOR UNITS

INDOOR UNITS



Low static pressure duct

Medium pressure duct (A5 type)

High Static Pressure Duct

Fresh Air Processing Unit



## Low Static Pressure Duct

### Low Sound Level >>

Utilizes the centrifugal type blower, provides a minimum noise level of 24dB (A), an excellent choice for hotels and other sound-sensitive locations.



### Compact Design >>

Uniformed height of 210mm, compact design for easy locate where ceiling space is limited. Entire body adopts fireproof plastic material, the minimum weight is 14kg.

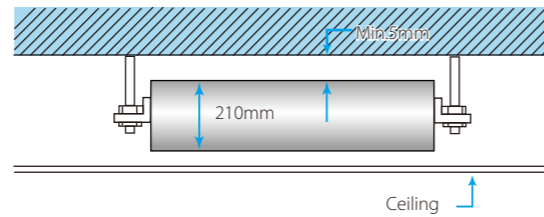

### Options >>

Drain pump with a 750mm pumphead is an optional accessory.

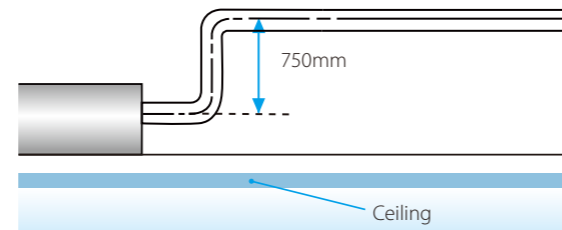

### V Shape Evaporator >>

V shape evaporator design enhances heat exchanging efficiency by around 22%.

### Easy Installation and Maintenance >>

The EXV is fixed inside the indoor unit.



## Specifications

Model	MDV-D18T3/N1-C	MDV-D22T3/N1-C	MDV-D28T3/N1-C	MDV-D36T3/N1-C	MDV-D45T3/N1-C	MDV-D56T3/N1-C	MDV-D71T3/N1-C		
Power supply	1-phase,220-240V,50Hz								
Capacity	Cooling	kW	1.8	2.2	2.8	3.6	4.5	5.6	7.1
	Heating	kW	2.2	2.6	3.2	4.0	5.0	6.3	8.0
Power input	Cooling	W	62	62	62	65	105	105	130
	Heating	W	62	62	62	65	105	105	130
Airflow rate(H/M/L)	m³/h	578/512/409	578/512/409	578/512/409	617/551/441	824/690/609	824/690/609	1060/970/811	
External static pressure(Min/Std/Max)	Pa	0/10/30	0/10/30	0/10/30	0/10/30	0/10/30	0/10/30	0/10/30	
Sound pressure level(H/M/L)	dB(A)	35/27/24	35/27/24	35/27/24	38/32/28	39/32/29	39/32/29	41/33/30	
Net dimension(WxHxD)	mm	740x210x470	740x210x470	740x210x470	740x210x470	960x210x470	960x210x470	1180x210x470	
Packing dimension(WxHxD)	mm	910x230x510	910x230x510	910x230x510	910x230x510	1130x230x510	1130x230x510	1350x230x510	
Net/gross weight	kg	14/17.5	14/17.5	14/17.5	14/17.5	17.5/22	17.5/22	21/26.5	
Piping connections	Liquid/gas pipe	mm	Φ6.35/Φ12.7	Φ6.35/Φ12.7	Φ6.35/Φ12.7	Φ6.35/Φ12.7	Φ6.35/Φ12.7	Φ9.53/Φ15.9	Φ9.53/Φ15.9
	Drain pipe	mm	OD Φ25	OD Φ25	OD Φ25	OD Φ25	OD Φ25	OD Φ25	OD Φ25
Standard controller	Wireless remote controller								

Notes:

- Nominal cooling capacities are based on the following conditions: return air temperature: 27°CDB, 19°CWB, outdoor temperature: 35°CDB, equivalent ref. piping: 7.5m(horizontal).
- Nominal heating capacities are based on the following conditions: return air temperature: 20°CDB, outdoor temperature: 7°CDB, 6°CWB, equivalent ref. piping: 7.5m(horizontal).
- Sound level is measured at 1.4m below the air outlet.
- External static pressure is based on high speed indoor air flow.
- No standard filter and air plenum box.

## Medium Static Pressure Duct (A5 type)

### Compact Size >>

Only 210mm (models 15~71) or 270mm (models 80~112) or 300mm (model 140) in height.

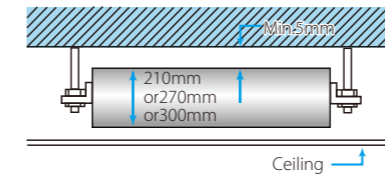

### Flexible Control and Easy Maintenance >>

The electrical control box can be removed 1m away from the unit for easy maintenance access. Customers need to request this service in advance for it is done at Midea CAC factory. Standard functional ports are included such as Remote On/Off Dry contact switch and Alarm signal output (220V).



## Specifications

Model	MDV-D15T2/N1-DA5	MDV-D22T2/N1-DA5	MDV-D28T2/N1-DA5	MDV-D36T2/N1-DA5	MDV-D45T2/N1-DA5	MDV-D56T2/N1-DA5		
Power supply	1-phase,220-240V,50Hz							
Capacity	Cooling	kW	1.5	2.2	2.8	3.6	4.5	5.6
	Heating	kW	1.7	2.6	3.2	4.0	5.0	6.3
Power input	Cooling	W	56	57	57	61	98	103
	Heating	W	56	57	57	61	98	103
Airflow rate(H/M/L)	m³/h	538/456/375	538/456/375	538/456/375	597/514/429	811/684/575	811/684/575	
External static pressure(Min/Std/Max)	Pa	0/10/30	0/10/30	0/10/30	0/10/30	0/10/30	0/10/30	
Sound pressure level(H/M/L)	dB(A)	35.8/34.6/31.4	36/35/32	37/35/32	38.6/37.5/33.8	39/37.9/34	39/37.9/34	
Net dimension(WxHxD)	mm	780x210x500	780x210x500	780x210x500	780x210x500	1000x210x500	1000x210x500	
Packing dimension(WxHxD)	mm	870x285x525	870x285x525	870x285x525	870x285x525	1115x285x525	1115x285x525	
Net/gross weight	kg	17.5/20.5	17.5/20	17.5/20	17.5/20	22.5/26	22.5/26	
Piping connections	Liquid/gas pipe	mm	Φ6.35/Φ12.7	Φ6.35/Φ12.7	Φ6.35/Φ12.7	Φ6.35/Φ12.7	Φ6.35/Φ12.7	Φ9.53/Φ15.9
	Drain pipe	mm	OD Φ25	OD Φ25	OD Φ25	OD Φ25	OD Φ25	OD Φ25
Standard controller	Wired controller							

Model	MDV-D71T2/N1-DA5	MDV-D80T2/N1-BA5	MDV-D90T2/N1-BA5	MDV-D112T2/N1-BA5	MDV-D140T2/N1-BA5		
Power supply	1-phase,220-240V,50Hz						
Capacity	Cooling	kW	7.1	8.0	9.0	11.2	14.0
	Heating	kW	8.0	9.0	10.0	12.5	15.5
Power input	Cooling	W	140	198	200	313	274
	Heating	W	140	198	200	313	274
Airflow rate(H/M/L)	m³/h	1029/934/781	1345/1165/1013	1345/1165/1013	1800/1556/1400	1905/1636/1400	
External static pressure(Min/Std/Max)	Pa	0/10/30	10/20/50	10/20/50	10/40/80	10/40/100	
Sound pressure level(H/M/L)	dB(A)	41.4/39/35	45.4/39.8/37	45.4/39.8/37	48.0/41.9/38	47.7/43.2/39.0	
Net dimension(WxHxD)	mm	1220x210x500	1230x270x775	1230x270x775	1230x270x775	1290x300x865	
Packing dimension(WxHxD)	mm	1335x285x525	1355x350x795	1355x350x795	1355x350x795	1400x375x925	
Net/gross weight	kg	28/31.5	38/46.5	40/48	40/48	49/58	
Piping connections	Liquid/gas pipe	mm	Φ9.53/Φ15.9	Φ9.53/Φ15.9	Φ9.53/Φ15.9	Φ9.53/Φ15.9	Φ9.53/Φ15.9
	Drain pipe	mm	OD Φ25	OD Φ25	OD Φ25	OD Φ25	OD Φ25
Standard controller	Wired controller						

Notes:

- Nominal cooling capacities are based on the following conditions: return air temperature: 27°CDB, 19°CWB, outdoor temperature: 35°CDB, equivalent ref. piping: 7.5m(horizontal).
- Nominal heating capacities are based on the following conditions: return air temperature: 20°CDB, outdoor temperature: 7°CDB, 6°CWB, equivalent ref. piping: 7.5m(horizontal).
- Sound level is measured at 1.4m below the air outlet.
- External static pressure is based on high speed indoor air flow.

## High Static Pressure Duct

### Flexible Duct Design >>

External static pressure can be up to 196Pa (models 71 to 160) or 280Pa (models 200 to 560).

The maximum length for air supply is about 14m at a height of 6.5m.

With a 420mm (models 71 to 160) thick body, the minimum distance required above the ceiling is 450mm.

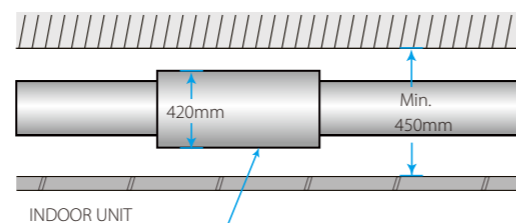
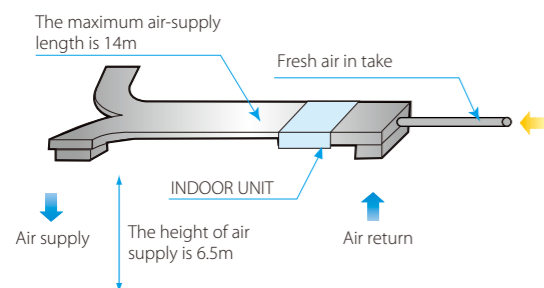

### Double-skin Drainage Pan >>

Double-skin drainage pan provides double protection for ceilings (models 71 to 160 and models 400 to 560).

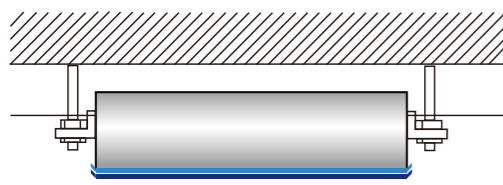

### Option >>

Drain pump with 750mm pump head is optional (models 71 to 160).

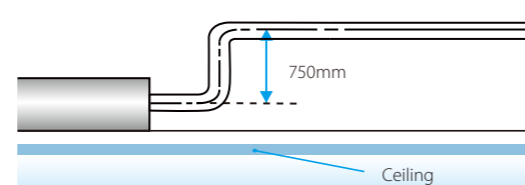

### Convenient Installation >>

The EXV is fixed inside the indoor unit (models 71 to 160), requires no extra connection.

Standard filter is housed in an aluminum frame (models 71 to 280), which is removable from the bottom in a downward direction.

Flange for air inlet/outlet duct connection is standard.

### Flexible Control and Convenient for Maintenance >>

Wired remote controller KJR-29B1/BK-E comes standard.

The display board is connected to the E-box in factory, easier troubleshooting with LED display.

Easy access filters both at the rear & bottom.

Standard functional port such as remote on/off dry contact.



## Specification

Model	MDV-D71T1/N1-B	MDV-D80T1/N1-B	MDV-D90T1/N1-B	MDV-D112T1/N1-B	MDV-D140T1/N1-B	MDV-D160T1/N1-B		
Power supply	1-phase,220-240V,50Hz							
Capacity	Cooling	kW	7.1	8.0	9.0	11.2	14.0	16.0
	Heating	kW	8.0	9.0	10.0	12.5	16.0	17.0
Power input	Cooling	W	263	263	423	524	724	940
	Heating	W	263	263	423	524	724	940
Airflow rate(H/M/L)	m³/h	1443/1361/1218	1416/1338/1220	1951/1741/1518	2116/1936/1520	3000/2618/2226	3620/3044/2744	
External static pressure(Min/Std/Max)	Pa	25/25/196	37/37/196	37/37/196	50/50/196	50/50/196	50/50/196	
Sound pressure level(H/M/L)	dB(A)	48/46/44	48/46/44.5	52/49/47	52/49/47	53/50/48	54/52/50	
Net dimension(WxHxD)	mm	952x420x690	952x420x690	952x420x690	952x420x690	1300x420x690	1300x420x690	
Packing dimension(WxHxD)	mm	1090x440x768	1090x440x768	1090x440x768	1090x440x768	1436x450x768	1436x450x768	
Net/gross weight	kg	45/50	45/50	46.5/52.4	50.6/56	68/70	70/77.5	
Piping connections	Liquid/gas pipe	mm	Φ9.53/Φ15.9	Φ9.53/Φ15.9	Φ9.53/Φ15.9	Φ9.53/Φ15.9	Φ9.53/Φ15.9	
	Drain pipe	mm	OD Φ25	OD Φ25	OD Φ25	OD Φ25	OD Φ25	
Standard controller	Wired controller							

Model	MDV-D200T1/N1-B	MDV-D250T1/N1-B	MDV-D280T1/N1-B	MDV-D400T1/N1	MDV-D450T1/N1	MDV-D560T1/N1		
Power supply	1-phase,220-240V,50Hz							
Capacity	Cooling	kW	20.0	25.0	28.0	40.0	45.0	56.0
	Heating	kW	22.5	26.0	31.5	45.0	50.0	63.0
Power input	Cooling	W	1516	1516	1516	2700	2700	3400
	Heating	W	1516	1516	1516	2700	2700	3400
Airflow rate(H/M/L)	m³/h	4700/4100/3599	4700/4100/3599	4700/4100/3599	7472/6072/4995	7472/6072/4995	9550/7950/6600	
External static pressure(Min/Std/Max)	Pa	50/200/280	50/200/280	50/200/280	50/200/280	50/200/280	50/200/280	
Sound pressure level(H/M/L)	dB(A)	59/55/52	59/55/52	59/55/52	61/59/56	61/59/56	63/60/57	
Net dimension(WxHxD)	mm	1440x505x925	1440x505x925	1440x505x925	1970x668x902.5	1970x668x902.5	1970x668x902.5	
Packing dimension(WxHxD)	mm	1509x550x990	1509x550x990	1509x550x990	2095x800x964	2095x800x964	2095x800x964	
Net/gross weight	kg	115/129	115/129	115/129	232/245	232/245	235/250	
Piping connections	Liquid/gas pipe	mm	Φ9.53x2/Φ15.9x2	Φ9.53x2/Φ15.9x2	Φ9.53x2/Φ15.9x2	Φ9.53x2/Φ22.2x2	Φ9.53x2/Φ22.2x2	
	Drain pipe	mm	OD Φ32	OD Φ32	OD Φ32	OD Φ32	OD Φ32	
Standard controller	Wired controller							

Notes:

- Nominal cooling capacities are based on the following conditions: return air temperature: 27°CDB, 19°CWB, outdoor temperature: 35°CDB, equivalent ref. piping: 7.5m(horizontal).
  - Nominal heating capacities are based on the following conditions: return air temperature: 20°CDB, outdoor temperature: 7°CDB, 6°CWB, equivalent ref. piping: 7.5m(horizontal).
  - Sound level is measured at 1.4m below the air outlet.
- External static pressure is based on high speed indoor air flow.

## Fresh Air Processing Unit

### 100% Fresh Air Processing Unit >>

Both fresh air filtration and heating/cooling can be achieved in a single system.

Indoor units and fresh air processing unit can be connected to the same refrigerant system, increasing design flexibility and greatly reducing total system costs.

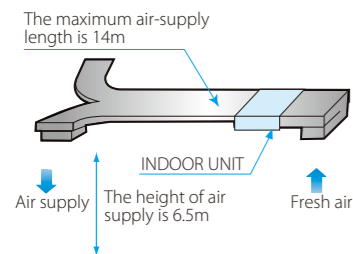

### High External Static Pressure >>

External static pressure can be up to 196Pa(models 125 to 140) and 280Pa(models 200 to 280) for more flexible duct applications. The maximum length of air supply is around 14m and the maximum height of air supply is about 6.5m.

### Healthy and Comfortable >>

Fresh air is imported, providing a healthy and comfortable living environment.

Four speed fan motor(model 125&140).

## Specification

Model	MDV-D125T1/N1-FA	MDV-D140T1/N1-FA	MDV-D200T1/N1-FA	MDV-D250T1/N1-FA	MDV-D280T1/N1-FA		
Power supply	1-phase,220-240V,50Hz						
Capacity	Cooling	kW	12.5	14.0	20.0	25.0	28.0
	Heating	kW	10.5	12.0	18.0	20.0	22.0
Power input	Cooling	W	430	430	1000×2	1063×2	1063×2
	Heating	W	430	430	1000×2	1063×2	1063×2
Airflow rate(H/M/L)	m <sup>3</sup> /h	2142/1870/1611	2142/1870/1611	2870/2620/2150	3005/2700/2250	3005/2700/2250	
External static pressure(Min/Std/Max)	Pa	30/50/196	30/50/196	50/200/280	50/200/280	50/200/280	
Sound pressure level(H/M/L)	dB(A)	54/52/50	54/52/50	54/53/51	55/54/52	55/54/52	
Net dimension(W×H×D)	mm	1300×420×690	1300×420×690	1440×505×925	1440×505×925	1440×505×925	
Packing dimension(W×H×D)	mm	1436×450×768	1436×450×768	1509×550×990	1509×550×990	1509×550×990	
Net/gross weight	kg	69.5/76	69.5/76	115/125	115/125	115/125	
Piping connections	Liquid/gas pipe	mm	Φ9.53/Φ15.9	Φ9.53/Φ15.9	Φ9.53/Φ15.9	Φ9.53/Φ15.9	
	Drain pipe	mm	OD Φ25	OD Φ25	OD Φ32	OD Φ32	
Operation temperature range	°C	Heating: -5~16; Fan only: 16~20; Cooling: 20~43					
Standard controller		Wired controller					

#### Notes:

- Nominal cooling capacities are based on the following conditions: outdoor air temperature: 33°CDB, 28°CWB, equivalent ref. piping: 7.5m(horizontal).
- Nominal heating capacities are based on the following conditions: outdoor air temperature: 0°CDB, -2.9°CWB, equivalent ref. piping: 7.5m(horizontal).
- Sound level is measured at 1.4m below the air outlet.

External static pressure is based on high speed indoor air flow.

Connection Conditions:

The following restrictions must be observed in order to maintain the indoor units connection to the same system.

\* When outdoor-air processing units are connected, the total connection capacity must be within 50% to 100% of that of the outdoor units.

\* When outdoor-air processing units and standard indoor units are connected, the total connection capacity of the outdoor-air processing units must not exceed 30% that of the outdoor units.

\* Outdoor-air processing units can be used without indoor units.

\* The fresh air processing unit is not available for V4+R system & 8~26kW side discharge outdoor units.

## Console



### Compact Size and Stylish Design >>

The elegant and thin body complements the existing decor and saves space. The EXV is installed inside the indoor unit for added compactness.

### High Comfort >>

Flexible air flow: vertical auto swing and wide angle louvers ensure that warm air reaches every corner of the room and increases the air flow coverage.

Indoor unit adopts DC motor with five fan speeds to meet different requirements.

Applies the Fujikoki mechanical expansion valve which offers 2,000-stage element positioning to ensure precise flow control and lower modulation noise when the EXV is operating.

### Flexible Installation >>

Can be installed on the floor or lower wall.

As a floor standing type, air flow can be semi or fully accessed without losing capacity.



### Two Air Outlets and Four Air Inlets >>

Four directional of air inlet.

two options of air outlet: Up and Down, or Up only.



Top/bottom and right/left side, for better ventilation

## Specification

Model	MDV-D22Z/DN1-B	MDV-D28Z/DN1-B	MDV-D36Z/DN1-B	MDV-D45Z/DN1-B		
Power supply	1-phase,220-240V,50Hz					
Capacity	Cooling	kW	2.2	2.8	3.6	4.5
	Heating	kW	2.6	3.2	4.0	5.0
Power input	Cooling	W	20	25	25	45
	Heating	W	20	25	25	45
Airflow rate(H/M/L)	m <sup>3</sup> /h	430/345/229	510/430/229	510/430/229	660/512/400	
Sound pressure level(H/M/L)	dB(A)	38/32/26	39/33/27	39/33/27	42/39/36	
Net dimension(W×H×D)	mm	700×210×600	700×210×600	700×210×600	700×210×600	
Packing dimension(W×H×D)	mm	810×305×710	810×305×710	810×305×710	810×305×710	
Net/gross weight	kg	14/19	15/20	15/20	15/20	
Piping connections	Liquid/gas pipe	mm	Φ6.35/Φ12.7	Φ6.35/Φ12.7	Φ6.35/Φ12.7	Φ6.35/Φ12.7
	Drain pipe	mm	OD Φ16	OD Φ16	OD Φ16	OD Φ16
Standard controller		Wireless remote controller				

#### Notes:

- Nominal cooling capacities are based on the following conditions: return air temperature: 27°CDB, 19°CWB, outdoor temperature: 35°CDB, equivalent ref. piping: 7.5m(horizontal).
- Nominal heating capacities are based on the following conditions: return air temperature: 20°CDB, outdoor temperature: 7°CDB, 6°CWB, equivalent ref. piping: 7.5m(horizontal).
- Sound level is measured 1m horizontally from the air-outlet and 1m vertically above the floor.



## Wall-mounted



### Various selections >>

M panel and S panel.

### Auto swing louver >>

The Auto Swing Louver function ensures that the air direction corresponds to the mode selected.

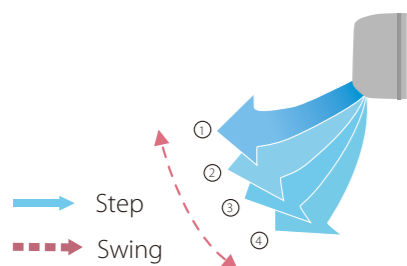

### Precise flow control >>

A 2000-stage element mechanical expansion valve ensures precise flow control whilst generating little modulation noise.

### High efficiency and low sound operation >>

M type products adopt DC brushless fan motor. The units operate in higher efficiency and lower sound level.

### Convenient installation >>

Multi-directional refrigerant outlet pipe: left/right/rear, more flexible for installation.

EXV is built-in the indoor unit, compact size.

Adopts new type fixing plate, stable and easy to install.

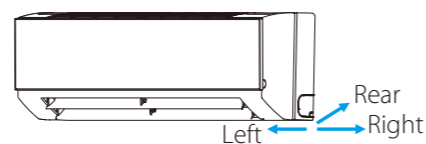

## Specification

### M panel

Model			MI-22G/DHN1-M	MI-28G/DHN1-M	MI-36G/DHN1-M	MI-45G/DHN1-M
Power supply			1-phase,220-240V,50/60Hz			
Capacity	Cooling	kW	2.2	2.8	3.6	4.5
	Heating	kW	2.4	3.2	4	5
Power input	Cooling	W	8	9	19	19
	Heating	W	8	9	19	19
Airflow rate (H/M/L)	m <sup>3</sup> /h		422/393/356	417/370/316	656/573/488	594/507/424
Sound pressure level (H/M/L)	dB(A)		31/30/29	31/30/29	33/32/30	35/33/31
Net dimension (WxHxD)	mm		835x280x203	835x280x203	990x315x223	990x315x223
Packing dimension (WxHxD)	mm		935x385x320	935x385x320	1085x420x335	1085x420x335
Net/ Gross weight	kg		8.4/12.1	9.5/13.1	11.4/15.5	12.8/16.9
Piping connections	Liquid/gas pipe	mm	Φ6.35/Φ12.7			
	Drain pipe	mm	OD Φ16.5			
Standard controller			Wireless remote controller			

Model			MI-56G/DHN1-M	MI-71G/DHN1-M	MI-80G/DHN1-M	MI-90G/DHN1-M
Power supply			1-phase,220-240V,50/60Hz			
Capacity	Cooling	kW	5.6	7.1	8	9
	Heating	kW	6.3	8	9	10
Power input	Cooling	W	27	49	53	82
	Heating	W	27	49	53	80
Airflow rate (H/M/L)	m <sup>3</sup> /h		747/648/547	1195/1005/809	1195/1005/809	1421/1067/867
Sound pressure level (H/M/L)	dB(A)		38/36/34	44/39/36	44/39/36	48/43/38
Dimension (WxHxD)	mm		990x315x223	1194x343x262	1194x343x262	1194x343x262
Packing (WxHxD)	mm		1085x420x335	1290x375x460	1290x375x460	1290x375x460
Net/ Gross weight	kg		12.8/16.9	17/22.4	17/22.4	17/22.4
Piping connections	Liquid/gas pipe	mm	Φ9.53/Φ15.9	Φ9.53/Φ15.9	Φ9.53/Φ15.9	Φ9.53/Φ15.9
	Drain pipe	mm	OD Φ16.5			
Standard controller			Wireless remote controller			

### S panel

Model			MDV-D15G/N1-S	MDV-D22G/N1-S	MDV-D28G/N1-S	MDV-D36G/N1-S	MDV-D45G/N1-S	MDV-D56G/N1-S
Power supply			1-phase,220-240V,50Hz					
Capacity	Cooling	kW	1.5	2.2	2.8	3.6	4.5	5.6
	Heating	kW	1.7	2.4	3.2	4	5	6.3
Power input	Cooling	W	28	28	28	28	45	45
	Heating	W	28	28	28	28	45	45
Airflow rate(H/M/L)	m <sup>3</sup> /h		427/389/336	525/480/430	525/480/430	590/520/480	860/755/630	925/860/755
Sound pressure level(H/M/L)	dB(A)		33/31/28	35/32/29	35/32/29	35/32/29	40/38/34	40/38/34
Net dimension(WxHxD)	mm		915x290x230	915x290x230	915x290x230	915x290x230	1072x315x230	1072x315x230
Packing dimension(WxHxD)	mm		1020x390x315	1020x390x315	1020x390x315	1020x390x315	1180x415x315	1180x415x315
Net/gross weight	kg		12.4/15.9	13/16.8	13/16.8	13/16.8	15.1/19.5	15.1/19.5
Piping connections	Liquid/gas pipe	mm	Φ6.35/Φ12.7	Φ6.35/Φ12.7	Φ6.35/Φ12.7	Φ6.35/Φ12.7	Φ6.35/Φ12.7	Φ9.53/Φ15.9
	Drain pipe	mm	OD Φ16.5	OD Φ16.5	OD Φ16.5	OD Φ16.5	OD Φ16.5	OD Φ16.5
Standard controller			Wireless remote controller					

Notes:

1. Nominal cooling capacities are based on the following conditions: return air temperature.: 27°CDB, 19°CWB, outdoor temperature.: 35°CDB, equivalent ref. piping: 7.5m(horizontal).
2. Nominal heating capacities are based on the following conditions: return air temperature.: 20°CDB, outdoor temperature.: 7°CDB, 6°CWB, equivalent ref. Piping: 7.5m(horizontal).
3. Sound level is measured 1m below the air outlet horizontally and vertically.

## Ceiling & Floor



- Auto Restart Function
- Auto Addressing
- Timer
- Auto Defrosting
- Easy-cleaning Panel
- Follow Me
- Anti-cold Air Function
- Auto Swing
- LED Display
- Built-in Filter
- Independent Dehumidification
- Wired Controller

### Convenient Installation >>

The slim and sleek structure design ensures easy installation. It can be installed into a corner of the ceiling even if the ceiling is very narrow.

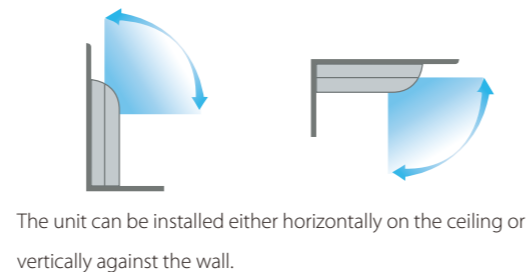
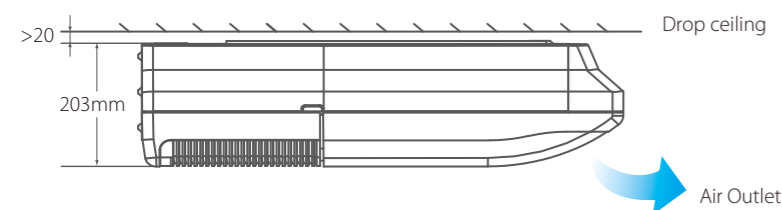

### Auto Swing and Wide Angle Air Flow >>

Two direction auto swing - vertical and horizontal. The range of horizontal air discharge is widened which secures wider air flow distribution to provide more comfortable air circulation no matter where the unit is set up. Three air flow speeds: low, medium and high; double air guides.

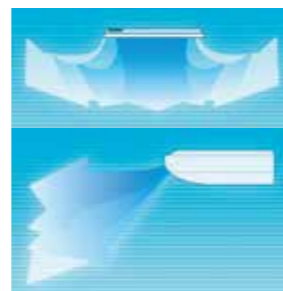

Auto Swing & Wide-angle Airflow

### More Comfortable >>

Adopts electrical expansion valve, ensuring precise flow control, lower modulation noise when EXV is operating. Low noise operations; minimum 36 dB(A). Smoother airflow and less turbulence due to the multi-blade fan and the air guide design.

## Specification

Model			MDV-D36DL/N1-C	MDV-D45DL/N1-C	MDV-D56DL/N1-C	MDV-D71DL/N1-C	MDV-D80DL/N1-C
Power supply			1-phase,220-240V,50Hz				
Capacity	Cooling	kW	3.6	4.5	5.6	7.1	8.0
	Heating	kW	4.0	5.0	6.3	8.0	9.0
Power input	Cooling	W	49	120	122	125	130
	Heating	W	49	120	122	125	130
Airflow rate(H/M/L)		m <sup>3</sup> /h	650/570/500	800/600/500	800/600/500	800/600/500	1,200/900/700
Sound pressure level(H/M/L)		dB(A)	40/38/36	43/41/38	43/41/38	43/41/38	45/43/40
Net dimension(WxHxD)		mm	990x203x660	990x203x660	990x203x660	990x203x660	1280x203x660
Packing dimension(WxHxD)		mm	1089x296x744	1089x296x744	1089x296x744	1089x296x744	1379x296x744
Net/gross weight		kg	26/32	28/34	28/34	28/34	34.5/41
Piping connections	Liquid/gas pipe	mm	Φ6.35/Φ12.7	Φ6.35/Φ12.7	Φ9.53/Φ15.9	Φ9.53/Φ15.9	Φ9.53/Φ15.9
	Drain pipe	mm	OD Φ25	OD Φ25	OD Φ25	OD Φ25	OD Φ25
Standard controller			Wireless remote controller				

Model			MDV-D90DL/N1-C	MDV-D112DL/N1-C	MDV-D140DL/N1-C	MDV-D160DL/N1-C
Power supply			1-phase,220-240V,50Hz			
Capacity	Cooling	kW	9.0	11.2	14.0	16.0
	Heating	kW	10.0	12.5	15.0	18.0
Power input	Cooling	W	130	182	182	300
	Heating	W	130	182	182	300
Airflow rate(H/M/L)		m <sup>3</sup> /h	1200/900/700	1980/1860/1730	1980/1860/1730	1980/1860/1730
Sound pressure level(H/M/L)		dB(A)	45/43/40	47/45/42	47/45/42	47/45/42
Net dimension(WxHxD)		mm	1280x203x660	1670x244x680	1670x244x680	1670x285x680
Packing dimension(WxHxD)		mm	1379x296x744	1764x329x760	1764x329x760	1775x377x760
Net/gross weight		kg	34.5/41	54/59	54/59	57.5/63.5
Piping connections	Liquid/gas pipe	mm	Φ9.53/Φ15.9	Φ9.53/Φ15.9	Φ9.53/Φ15.9	Φ9.53/Φ15.9
	Drain pipe	mm	OD Φ25	OD Φ25	OD Φ25	OD Φ25
Standard controller			Wireless remote controller			

Notes:

- Nominal cooling capacities are based on the following conditions: return air temperature: 27°CDB, 19°CWB, outdoor temperature: 35°CDB, equivalent ref. piping: 7.5m(horizontal).
- Nominal heating capacities are based on the following conditions: return air temperature: 20°CDB, outdoor temperature: 7°CDB, 6°CWB, equivalent ref. piping: 7.5m(horizontal).
- Floor standing: Sound level is measured 1m horizontally and 1m vertically from the air-outlet.  
Ceiling mounted: Sound level is measured 1m horizontally and 1m vertically from the air-outlet.

## Floor Standing



### Easy Installation >>

Floor standing types can be hung on the wall or installed on the floor. The floor type unit can make cleaning and maintenance much easier. Running piping from the rear allows the unit to be hung on walls. Cleaning under the unit, where dust tends to accumulate, is considerably easier.

### Optional Panel Styles >>

Concealed type's body is concealed in the skirting board to improve aesthetics. The body is just 212mm deep, and can be installed at the room's perimeter. Special installation methods eliminate noise in the room area. Both air intake from front and air intake from below are optional for exposed floor standing type.

Concealed floor standing type



F3B series concealed type



Air intake from front(F4 series)



Air intake from below(F5 series)

## Specification

Model	MDV-D22Z/N1-F3B	MDV-D28Z/N1-F3B	MDV-D36Z/N1-F3B	MDV-D45Z/N1-F3B	MDV-D56Z/N1-F3B	MDV-D71Z/N1-F3B	MDV-D80Z/N1-F3B		
Power supply	1-phase,220-240V,50Hz								
Capacity	Cooling	kW	2.2	2.8	3.6	4.5	5.6	7.1	8.0
	Heating	kW	2.4	3.2	4.0	5.0	6.3	8.0	9.0
Power input	Cooling	W	40	46	46	49	88	130	130
	Heating	W	40	46	46	49	88	130	130
Airflow rate(H/W/L)	m <sup>3</sup> /h	530/456/400	569/485/421	624/522/375	660/542/440	1,150/970/830	1,380/1,100/870	1,380/1,100/870	
Sound pressure level(H/W/L)	dB(A)	36/33/29	36/33/29	37/34/30	37/34/30	41/35/31	44/39/33	44/39/33	
Net dimension(WxHxD)	mm	840x545x212	840x545x212	1040x545x212	1040x545x212	1340x545x212	1340x545x212	1340x545x212	
Packing dimension(WxHxD)	mm	939x639x305	939x639x305	1139x639x305	1139x639x305	1425x639x305	1425x639x305	1425x639x305	
Net/gross weight	kg	25/27	25/27	29.5/34	29.5/34	33/39	33/39	36/40	
Piping connections	Liquid/gas pipe	mm	Φ6.35/Φ12.7	Φ6.35/Φ12.7	Φ6.35/Φ12.7	Φ6.35/Φ12.7	Φ9.53/Φ15.9	Φ9.53/Φ15.9	Φ9.53/Φ15.9
	Drain pipe	mm	OD Φ25	OD Φ25	OD Φ25	OD Φ25	OD Φ25	OD Φ25	OD Φ25
Standard controller	Wireless remote controller								

Model	MDV-D22Z/N1-F4	MDV-D28Z/N1-F4	MDV-D36Z/N1-F4	MDV-D45Z/N1-F4	MDV-D56Z/N1-F4	MDV-D71Z/N1-F4	MDV-D80Z/N1-F4		
Model	MDV-D22Z/N1-F5	MDV-D28Z/N1-F5	MDV-D36Z/N1-F5	MDV-D45Z/N1-F5	MDV-D56Z/N1-F5	MDV-D71Z/N1-F5	MDV-D80Z/N1-F5		
Power supply	1-phase,220-240V,50Hz								
Capacity	Cooling	kW	2.2	2.8	3.6	4.5	5.6	7.1	8.0
	Heating	kW	2.4	3.2	4.0	5.0	6.3	8.0	9.0
Power input	Cooling	W	40	46	46	49	88	130	130
	Heating	W	40	46	46	49	88	130	130
Airflow rate(H/W/L)	m <sup>3</sup> /h	530/456/400	569/485/421	624/522/375	660/542/440	1,150/970/830	1,380/1,100/870	1,380/1,100/870	
Sound pressure level(H/W/L)	F4	dB(A)	36/33/29	36/33/29	37/34/30	37/34/30	41/35/31	44/39/33	44/39/33
	F5	dB(A)	36/33/29	36/33/29	37/34/30	37/34/30	41/35/31	44/39/33	44/39/33
Net dimension(WxHxD)	F4	mm	1000x596x225	1000x596x225	1200x596x225	1200x596x225	1500x596x225	1500x596x225	1500x596x225
	F5	mm	1000x677x220	1000x677x220	1200x677x220	1200x677x220	1500x677x220	1500x677x220	1500x677x220
Packing dimension(WxHxD)	F4	mm	1089x683x312	1089x683x312	1289x683x312	1289x683x312	1589x683x312	1589x683x312	1589x683x312
	F5	mm	1182x683x312	1182x683x312	1382x683x312	1382x683x312	1682x683x312	1682x683x312	1682x683x312
Net/gross weight	F4	kg	30/35	30/35	36/44	36/44	41/46.5	41/46.5	42.5/48.5
	F5	kg	30/38	30/38	35.5/41	35.5/41	42/51	42/51	44/53
Piping connections	Liquid/gas pipe	mm	Φ6.35/Φ12.7	Φ6.35/Φ12.7	Φ6.35/Φ12.7	Φ6.35/Φ12.7	Φ9.53/Φ15.9	Φ9.53/Φ15.9	Φ9.53/Φ15.9
	Drain pipe	mm	OD Φ25	OD Φ25	OD Φ25	OD Φ25	OD Φ25	OD Φ25	OD Φ25
Standard controller	Wireless remote controller								

#### Notes:

- Nominal cooling capacities are based on the following conditions: return air temperature: 27°CDB, 19°CWB, outdoor temperature: 35°CDB, equivalent ref. piping: 7.5m(horizontal).
- Nominal heating capacities are based on the following conditions: return air temperature: 20°CDB, outdoor temperature: 7°CDB, 6°CWB, equivalent ref. piping: 7.5m(horizontal).
- Specifications of F3B series are measured at 10Pa external static pressure and F4/F5 series at 0Pa.
- Sound level is measured 1m horizontally from the air-outlet and 1m vertically above the floor.



# Control Systems



## Wireless Remote Controller

RM02  
RM05

## Wired Controller

KJR-29B  
KJR-90D  
KJR-86C  
KJR-12B  
KJR-120B  
KJR-120C  
KJR-27B

## Centralized Controller & Monitor

CCM30  
MD-CCM03  
MD-CCM09  
KJR-90B  
MD-CCM02

## Network Control Software & Gateways

IMM Software & M-Interface  
Data Converter CCM15  
KNX Gateway MD-KNX  
BACnet Gateway CCM08  
LonWorks Gateway LonGW64  
Modbus Gateway CCM-18A

## Accessories

Hotel Key Card Interface Module MD-NIM05  
Infrared Sensor Controller MD-NIM09  
3-Phase Protector  
Digital Power Ammeter  
Indoor Unit Group Controller-KJR-150A  
Remote Alarm Controller KJR-32B  
Network Electricity Distribution Module MD-NIM10  
AHU Control Box  
Midea Outdoor Unit Diagnosis

## Wireless Remote Controller



### Auto Mode >>

Auto mode is specially designed for V4+R system. Can automatically switch between cooling and heating mode based on the temperature difference between the indoor temperature and set temperature.

\* Runs cooling mode only for the 2-pipe system.

### Background Light >>

The background light allows users to operate the device in a dark room. The device lights up when a button is pressed, and turns off when a given operation is completed.

### Address Setting >>

In addition to the machine's auto addressing function, users can set the indoor unit's address on the wireless remote controller RM05/RM02.



### Follow Me >>

With the follow me function, the temperature sensor built-in to the remote controller automatically adjusts temperature and sends it to the indoor unit, making the room more comfortable.

\*The Follow Me function is available in RM02.



## Features

Model name	RM02	RM05	RM12
Mode selection	●	●	●
Temperature setting	●	●	●
Fan speed control	●	●	●
Keyboard lock	●	●	●
Eco mode	●	●	—
Swing function	●	●	●
Air direction control	●	●	●
24hr timer	●	●	●
Clock display	—	●	●
Address setting	●	●	●
Follow me function	●	—	●
One-key 26°C	●	—	—
Background light	●	●	●

Notes:

- The ECO function needs to match with the corresponding indoor units.
- : available — : unavailable

## Specifications

Model	RM02	RM05	RM12
Dimensions (HxWxD)(mm)	150x60x15	150x65x20	170x48x20
Batteries	1.5V(LR03/AAA)×2		

## Wired Controller



KJR-86C KJR-29B KJR-90D



- Auto mode
- Dry mode
- Heat mode
- Cool mode
- Fan mode
- 24h Timer
- Lock
- Clean filter reminder
- Address setting
- Follow Me
- Silent mode

### Clean Filter Reminder >>

The wired controller records the total running time of the indoor unit. When the accumulated running time reaches the pre-set value, the system will remind users to clean the indoor unit's filter. Cleaning the filter regularly keep indoor air fresh, clean and good for your health.

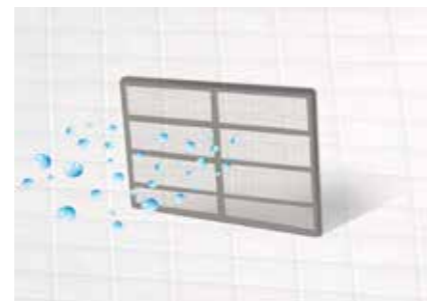

### Silent Mode >>

In cooling, heating and auto mode, operating silent mode can lower running noise by setting the fan speed to low for a quieter environment.



### Keyboard Locking >>

The locking function can be used to prevent other people from using the controller.

### Remote Signal Receiving Function >>

KJR-29B and KJR-90D provide a signal receiver for the remote controller. Signals from the remote control can be received by a wired controller, then sent to the indoor unit for easy control.

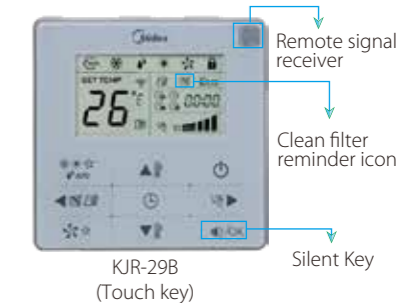

### Address Setting >>

KJR-29 and KJR-90D have an address setting function. Service personnel can set the address for the indoor unit for easy installation and future maintenance.



### Follow Me >>

The temperature sensor built-in to the wired controller senses the surrounding temperature and adjusts the room temperature for perfect comfort.

\*The Follow Me function is available in KJR-29B and KJR-90D.



### One-key 26°C >>

KJR-86C has a one-key 26°C function. For saving energy and remaining comfortable, 26°C is the ideal temperature.





## User Friendly Design >>

KJR-86C is a hidden mode controller specially designed for hotels, hospitals, schools and other similar types of buildings.

Hidden mode key controller:

Press the temperature buttons "▲" and "▼" simultaneously for 3 seconds to select the operation mode: COOL or HEAT.

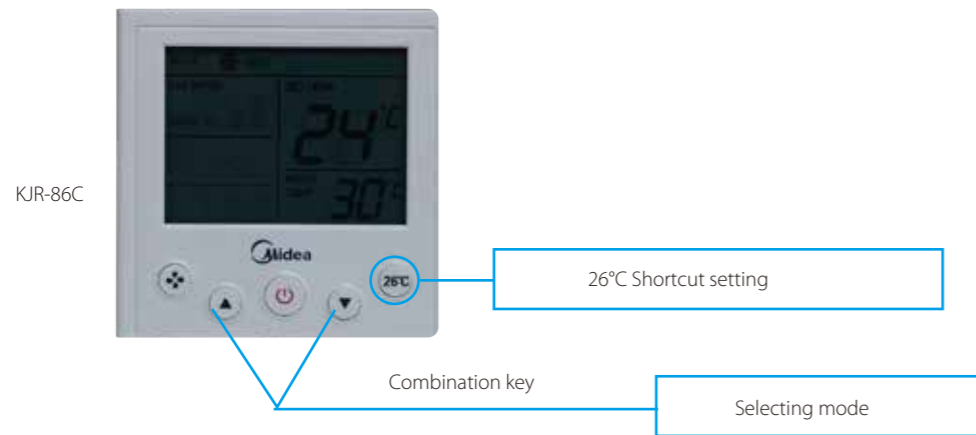

## User Friendly Installation >>

The background light function makes it easy to use in the dark. As small as an electric switch, the installation effect more attractive.



## Auto Restart Function >>

If the power fails, the system records running parameters such as: ON/OFF state, mode, Fan speed, Temperature, Swing and Locking status. When powered on again, the system automatically checks the status before the failure.

## KJR-12B



## Built-in Timer >>

The built-in daily timer offers automatically starts and stops the system at set times based on user needs.

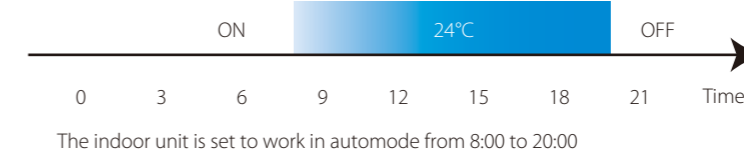

## Follow Me >>

The FOLLOW ME function enables the wired controller to detect the air temperature at the user's height instead of the ceiling or floor for accurate temperature configuration.

\*The Follow Me function is available in KJR-12B.

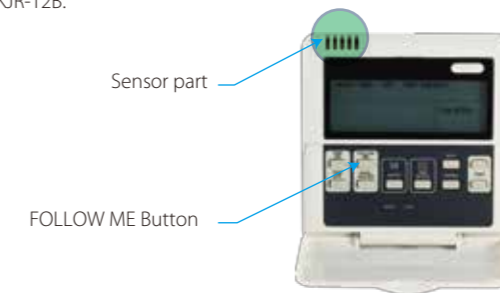

## Addresses Setting >>

The address setting function is coupled with easy installation and simple future maintenance. Service personnel can set the address for the indoor unit using, KJR-29B and KJR-90D.



## Easy Connection >>

The wired controller conveniently connects to the indoor unit's display panel via connecting wire.

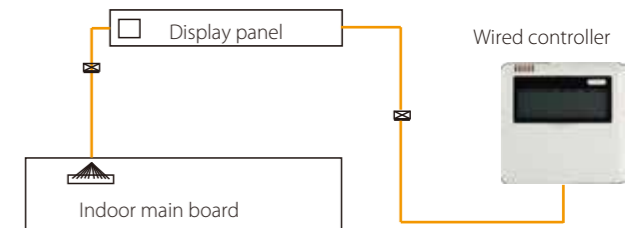

## V4 Plus R Wired Controller



### Auto Mode >>

Auto mode is specially designed for the V4 plus R series. In auto mode, the V4 plus R system can automatically switch between COOL or HEAT mode according to the temperature difference between Tf (indoor temperature) and Ts (setting temperature).  
\* KJR-120B is compatible with the 2-pipe system. In auto mode, it only can run in cooling mode.

### Error Display >>

If a malfunction occurs, the temperature setting display area will show the error code. The error status can be checked easily on the indoor unit's wired controller.

### Filter Cleaning Reminder >>

The wired controller records the total running time of the indoor unit. When the accumulated running time reaches the pre-set value, it will remind you to clean the air filter. Cleaning the filter regularly keeps the indoor air fresh and clean, and is good for your health.

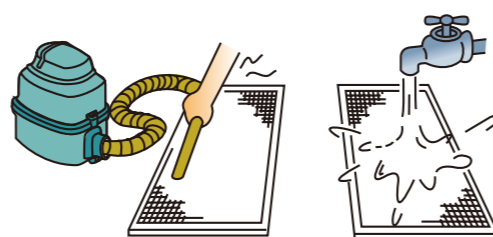

### Silent Mode >>

In cooling, heating, and auto mode, silent mode reduces the running noise by setting the fan speed to low so you can enjoy peace and quiet while remaining comfortable.



## Weekly Schedule Timer Wired Controller



### Simple Design >>

Weekly schedule wired controller can query the indoor temperature and the set parameters of the weekly schedule. It can show the error codes and running state of the indoor unit. The LCD backlight enables users to operate the device in the dark.

### Weekly Schedule Timer >>

The weekly schedule timer function allows users to set up to four scheduled periods per day for frequent adjustments. The Schedule feature allows you to program device behavior. If a device must follow a certain schedule, you can program the device to operate only at the scheduled times. Scheduled devices do not activate unless programmed to do so. They are centrally managed, significantly reducing energy consumption.

### Delay Function >>

This function is specifically designed for people who work overtime. Pressing the Delay button postpones system shutdown by 1 or 2 hours.

### Error Display >>

If a malfunction occurs, the temperature setting display area will show the error code. The error status can be checked easily on the indoor unit's wired controller.



### °F/°C Switch >>

Press the left-right and up-down buttons simultaneously for three seconds to switch between °F and °C.

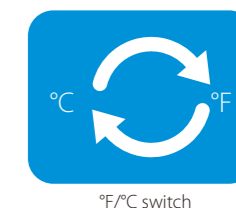

°F/°C switch

## HRV Wired Controller



KJR-27B is individually designed for HRV—Heat Recovery Ventilator. The HRV can work in the following modes: exhaust, air supply, bypass, heat exchange, and auto.

### Built-in Timer >>

Built-in daily timer offers the convenience of automatically starting and stopping the HRV at the times set

Setup screen example

Set to Wednesday: 8:00 to 20:00

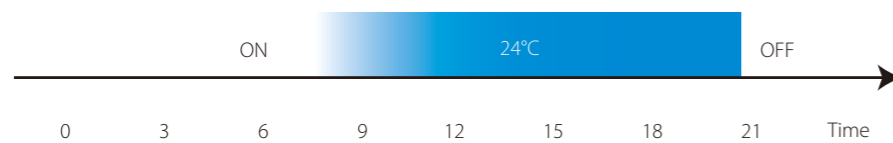

### Specifications

Model	KJR-29B	KJR-90C	KJR-86C	KJR-12B	KJR-27B	KJR-120B	KJR-120C
Dimensions (HxWxD)(mm)	120x120x20	86x86x16.5	86x86x18	120x120x15	120x120x15	120x120x20	120x120x20
Power (V)	DC 5V (Supplied by indoor unit)					DC 12V by IDU	

## Benefits

Model name	KJR-12B	KJR-29B	KJR-90D	KJR-86C	KJR-120B	KJR-120C
Fan speed control	●	●	●	●	●	●
Mode change	●	●	●	●	●	●
Auto mode for V4+R	—	—	—	—	●	—
Eco mode	●	—	●	—	—	—
Keyboard lock	●	●	●	—	●	●
Swing function	●	●	●	—	●	●
Background-light	●	●	●	●	●	●
24h timer	●	●	●	—	●	●
Clock display	—	●	●	—	●	●
Address setting	—	●	●	—	—	—
Receiving remote signal	—	●	●	—	—	—
Clean filter reminder	—	●	●	—	●	—
Follow me function	●	●	●	—	—	—
Silent mode	—	●	●	●	●	—
26°C shortcut setting	—	—	—	●	—	—
Display indoor temp.	—	—	—	●	—	—
°F/°C initial setting	—	●	●	—	●	●
Weekly schedule timer	—	—	—	—	—	●
Delay function	—	—	—	—	—	●
Auto restart	—	●	●	●	●	●
Error code display	—	—	—	—	●	●

Notes:

1. ECO function needs to match with the corresponding indoor units.
2. ● : available — : unavailable



# Centralized Controller & Monitor



## Indoor Centralized Controller



**CCM30**  
**MD-CCM03**  
**MD-CCM09**

- Swing
- Heat mode
- Cool mode
- Fan mode
- 24h Timer
- Keyboard lock
- Remote controller lock
- Cooling lock
- Heating lock
- Dry mode
- Weekly schedule
- Clean filter reminder
- Network access

### Centralized Control >>

The centralized controller is a multifunctional device that can control up to 64 indoor units within a maximum connection length of 1,200m. User can group control or individual control and the set temperature of each unit can also differ.

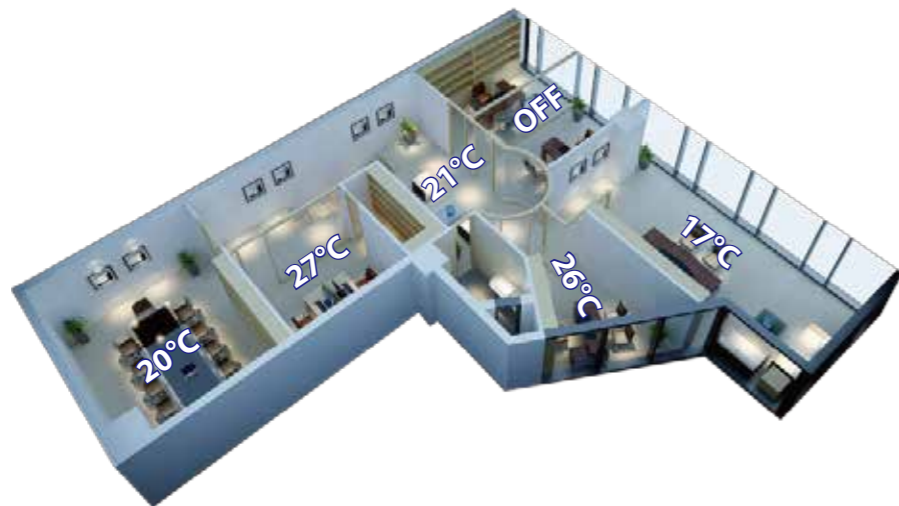

### Three Lock Modes >>

The centralized controller is a better way to manage indoor units. Users can choose to lock the wireless controller, running mode, or the centralized controller's keyboard.



### Wiring Example >>

The device connects to the master outdoor units of Midea's newly designed products to simplify and centralize the wiring configuration. The two connection methods are as follows:

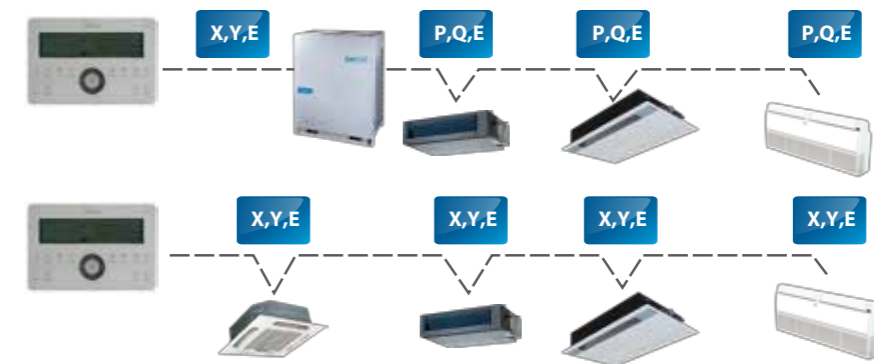

\*1. If it connects to XYE ports of master ODU, the ODU must be set to auto addressing mode.  
\*2. Some products can only be connected with MD-CCM09 from indoor side XYE ports.

### Application Example >>

Ensure the address is not repeated. Units can be from different systems, with up to 64 indoor units. This greatly reduces system limitations.

\*1. For the 2-pipe system, the running mode should be in the same mode.  
\*2. For 3-pipe system, the running mode can be set as required.



### Air Filter Cleaning Reminding Function >>

CCM30 is a new design and touch key controller. The reminder to clear the filter is only available on the touch-key central controller CCM30. The "FL" icon indicates that the air filter in a given indoor unit needs cleaning.

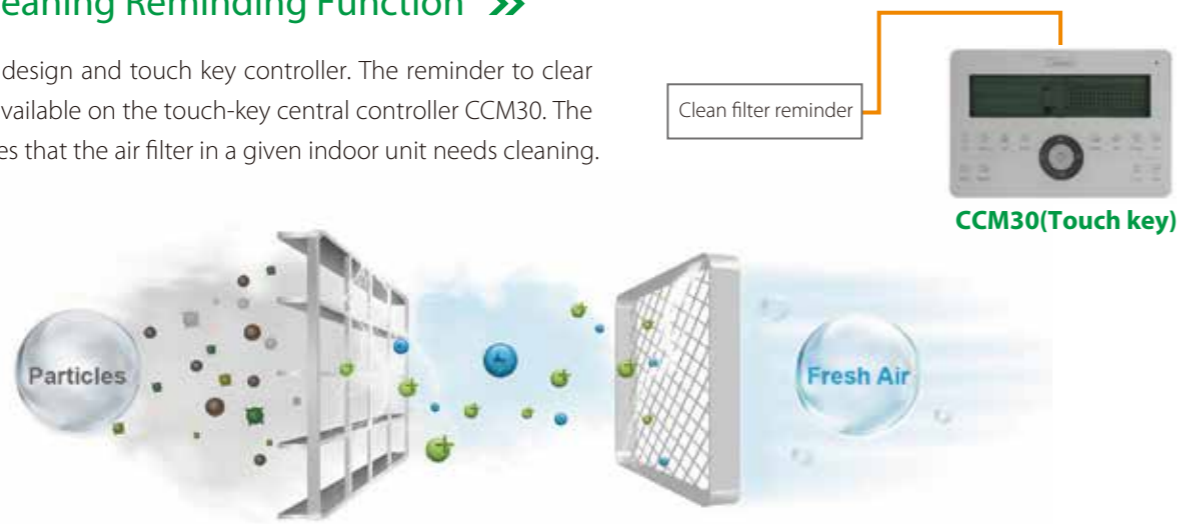

### Easy Installation >>

The centralized controller offers two installation modes. Unlike the B structure, the A structure must be embedded into the wall. Both are easy to operate.



\*A and B structure is available for CCM30

### Stylish Design >>

CCM's stylish design suits high-end environments. The keyboard lock function is used to prevent operating mistakes.



### Weekly Schedule for MD-CCM09 >>

MD-CCM09 is a weekly centralized controller. It can control 64 indoor units in a weekly schedule. Users can set up to four periods per day, and select the desired running mode and room temperature. The operating object can be a single indoor unit or all the indoor units.

	8:00	16:00	23:59
Sun	28°C	22°C	24°C
Mon	26°C	22°C	23°C
Tue	26°C	22°C	23°C
Wed	26°C	22°C	23°C
Thu	26°C	22°C	26°C
Fri	26°C	22°C	26°C
Sat	28°C	off	24°C

### Single/Unified Control Mode >>

The control object can either be a single unit or all units, which vastly simplifies the control process. Operation signal feedback ensures that all units are working in the correct mode.

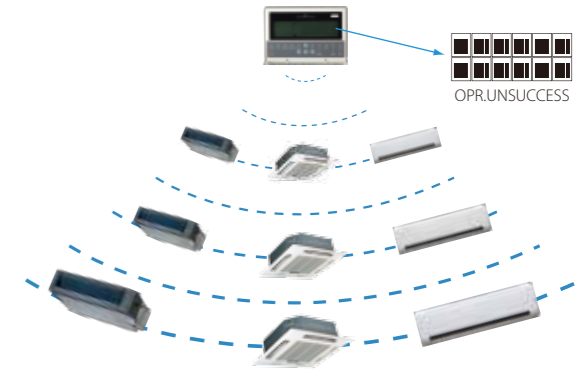

### Indoor Unit Working Status Display >>

Displays indoor units' working status and error codes, so users can easily identify faults by checking the error code table in the user's manual before contacting a service engineer.

Error code or protection code

Connecting status matrix

Current <b>88</b> # ALL Online ON OFF Protect Error Set. temp <b>88</b> °C	Mode Auto ❄️ ☀️ 🌀 🖱️ 🌀 Fan	<table border="1" style="width: 100%; text-align: center;"> <thead> <tr> <th colspan="2">Query</th> <th>Set</th> <th colspan="13">Opr. unsuccessful</th> </tr> <tr> <th>00</th><th>01</th><th>02</th><th>03</th><th>04</th><th>05</th><th>06</th><th>07</th><th>08</th><th>09</th><th>10</th><th>11</th><th>12</th><th>13</th><th>14</th><th>15</th> </tr> </thead> <tbody> <tr> <td>16</td><td>17</td><td>18</td><td>19</td><td>20</td><td>21</td><td>22</td><td>23</td><td>24</td><td>25</td><td>26</td><td>27</td><td>28</td><td>29</td><td>30</td><td>31</td> </tr> <tr> <td>32</td><td>33</td><td>34</td><td>35</td><td>36</td><td>37</td><td>38</td><td>39</td><td>40</td><td>41</td><td>42</td><td>43</td><td>44</td><td>45</td><td>46</td><td>47</td> </tr> <tr> <td>48</td><td>49</td><td>50</td><td>51</td><td>52</td><td>53</td><td>54</td><td>55</td><td>56</td><td>57</td><td>58</td><td>59</td><td>60</td><td>61</td><td>62</td><td>63</td> </tr> </tbody> </table> <p>Weekly Timer Off 🕒 📄 📶 🌀 🖱️ 📡 📶</p>	Query		Set	Opr. unsuccessful													00	01	02	03	04	05	06	07	08	09	10	11	12	13	14	15	16	17	18	19	20	21	22	23	24	25	26	27	28	29	30	31	32	33	34	35	36	37	38	39	40	41	42	43	44	45	46	47	48	49	50	51	52	53	54	55	56	57	58	59	60	61	62	63
Query		Set	Opr. unsuccessful																																																																															
00	01	02	03	04	05	06	07	08	09	10	11	12	13	14	15																																																																			
16	17	18	19	20	21	22	23	24	25	26	27	28	29	30	31																																																																			
32	33	34	35	36	37	38	39	40	41	42	43	44	45	46	47																																																																			
48	49	50	51	52	53	54	55	56	57	58	59	60	61	62	63																																																																			

### Access to Network Monitoring >>

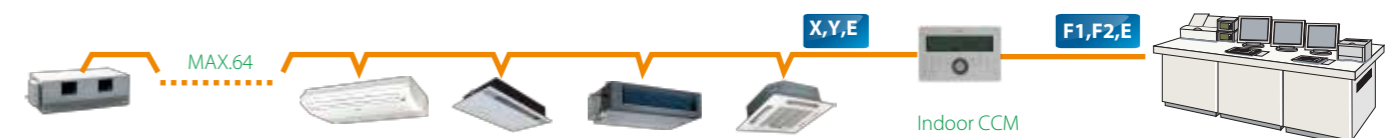

The centralized controller can connect up to 64 indoor units on the network monitoring and building management systems.



\*If it connects to XYE ports of master ODU, the ODU must be set to auto addressing mode.

Network access is only available for CCM03 and CCM30

## Benefits

Model	 CCM30	 MD-CCM03	 MD-CCM09
Max. number of indoor units	64	64	64
Group control	●	●	●
Individual control	●	●	●
Fan speed control	●	●	●
Mode selection	●	●	●
Mode lock	●	●	●
Remote controller lock	●	●	●
Keyboard lock	●	●	●
Weekly schedule timer	—	—	●
24h timer	●	●	●
Error check	●	●	●
Emergency start	●	●	●
Emergency stop	●	●	●
Background light	●	●	●
Swing function	●	●	●
Air filter cleaning reminder	●	—	—
Parameter query	●	●	●
BMS access	●	●	—

Notes:

● : available — : unavailable

## Specifications

Model	MD-CCM03	CCM30	MD-CCM09
Dimensions (H*W*D)(mm)	179x119x74	180x122x78 and 180x122x68	179x119x74
Power (V)	198-242V(50/60Hz)		

## Unified On/Off Controller

Stylish unified controller design with a clear panel.  
Can control single or group indoor units.

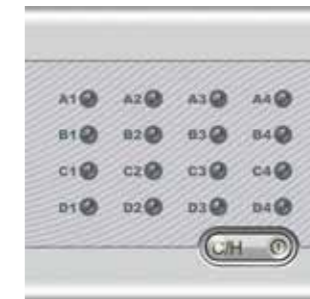

KJR-90B

### Unified Control >>

KJR-90B offers on/off and heating/cooling functions for indoor units based on preset temperatures to ensure easy management.



### Centralized Control >>

KJR-90B can be used to centrally control up to 16 indoor units.



### Light Indicator >>

The LEDs on KJR-90B indicate indoor units' running status for easy fault detection. The lights switch off automatically to save energy once an action is completed. The indicators are as follows:

Light	Blue	Red	Flash
Single On/Off key	Cooling/Fan	Heating	IDU Error
Unified On/Off key			EEPROM Error

### Easy Installation >>

KJR-90B can be easily mounted on the built-in cabinet:

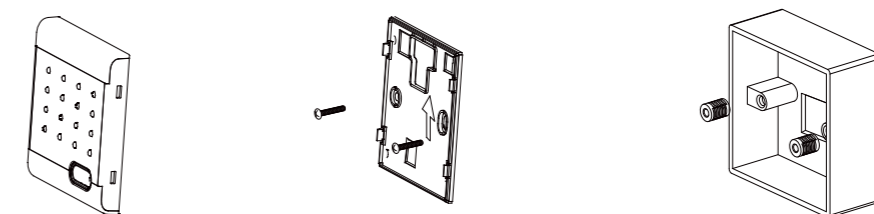

## Specifications

Model	KJR-90B
Dimensions (H*W*D)(mm)	90x86x8
Power (V)	DC 5V(Supplied by indoor unit)



## Outdoor Centralized Monitor

MD-CCM02



- Query parameters
- Power consumption
- Protection/ Error codes
- Communication by ODU
- Communication by PC
- Forced Cooling

### ODU Parameters Display >>

MD-CCM02 enables users to easily check outdoor units' running status, including frequency, temperature, current, pressure, protection codes and error codes.

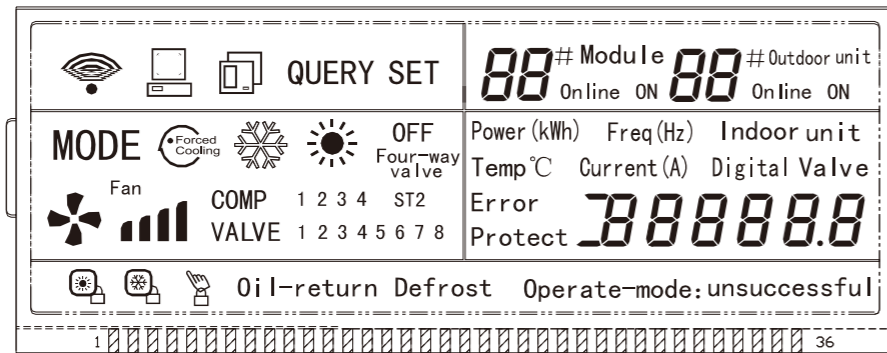

Graph 2 LCD Screen

### Access to Network Monitoring >>

MD-CCM02 can connect up to 8 refrigerant systems and 32 outdoor units to the network system.

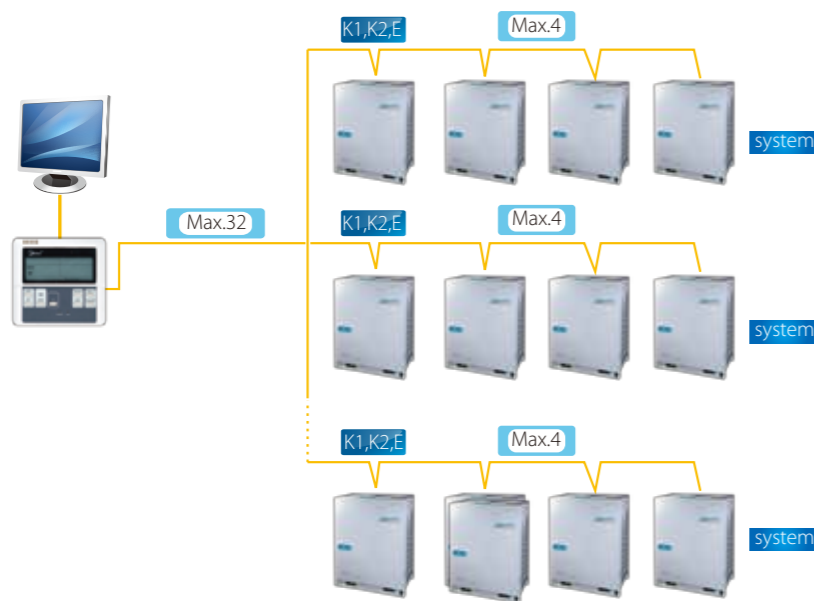

### Specifications

Model	MD-CCM02
Dimensions(HxWxD)(mm)	120x120x15
Power (V)	198-242V(50/60Hz)

## Network Control Software & Gateways

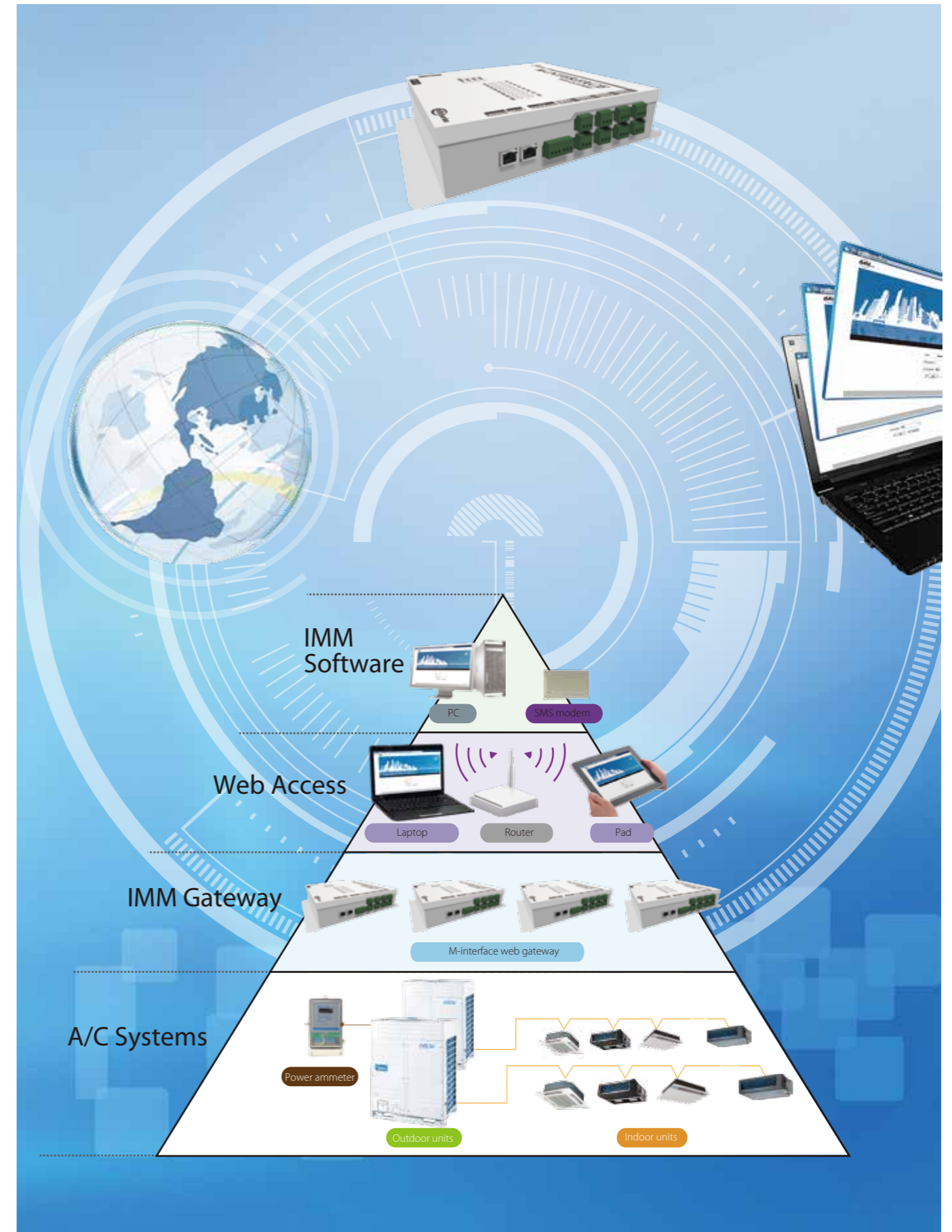

# Network Control Software & Gateways



## IMM(Intelligent Manager of Midea) 4th Generation Network Control System



IMM software



M-interface Gateway

Intelligent Manager of Midea is designed specifically to control VRF systems. Based on a centralized format, it controls and monitors all the system's functions. It can be used as a flexible multi-purpose system and applied to meet various requirements according to the scale, purpose, and control method of each building.

### Key Features >>

- ❖ Up to 4 M-interface gateways, 64 refrigerant systems, 1,024 indoor units, and 256 outdoor units can be controlled by one PC.
- ❖ User friendly operation
- ❖ Web access for M-interface gateway
- ❖ Central building monitoring and control
- ❖ Energy saving management
- ❖ Zone management
- ❖ Warning message
- ❖ \*SMS modem(optional)
- ❖ Electricity charge distribution
- ❖ Annual schedule management
- ❖ Low-load operation indicator
- ❖ Generate operational history reports (daily, weekly)
- ❖ Fault display & Warning message
- ❖ Clean filter reminder
- ❖ Emergency stop and Alarm signal output
- ❖ Multiple languages



Web Access function



Energy Saving Management



Schedule management



Visual Navigation



Warning Message



Data Backup



Multiple Languages



Electricity Charge Distribution

### Network Control Application >>

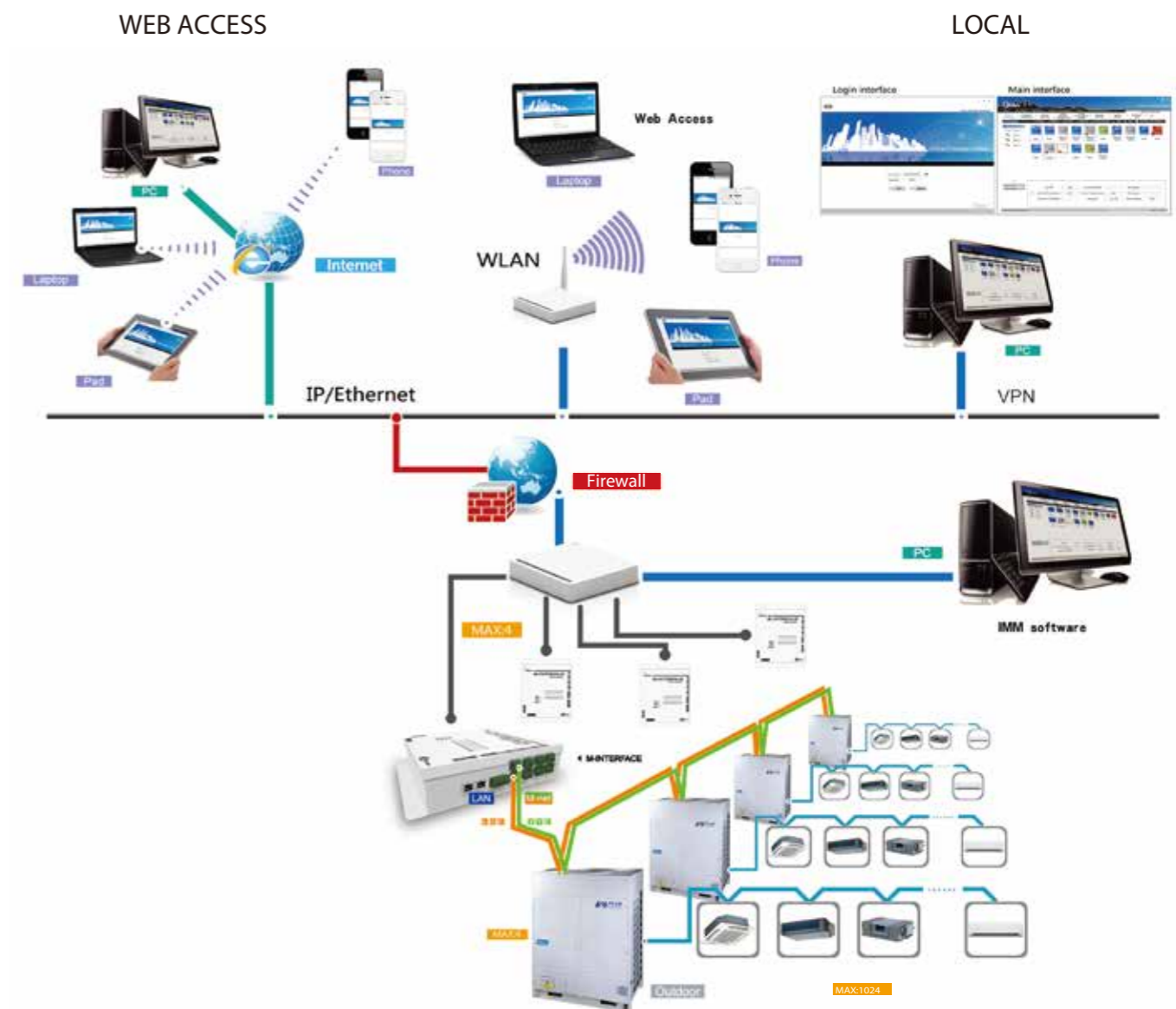

- ❖ Can run on Window 7\_32/64 bit, Window XP\_32 bit and Window 8.
- ❖ Can monitor and control A/C anytime, anywhere by PC, iPhone, iPad and notebook computer.
- ❖ Support WEB access: IE, Firefox, Safari and Chrome.
- ❖ Enables remote access through DSL, VPNs and so on.



## Simple Operation & Management >>

- ❖ Click & Operate, a user-friendly interface allows non-experts to easily run the building management system.
- ❖ IMM offers a massive, flexible, and highly efficient centralized management program.

Login interface

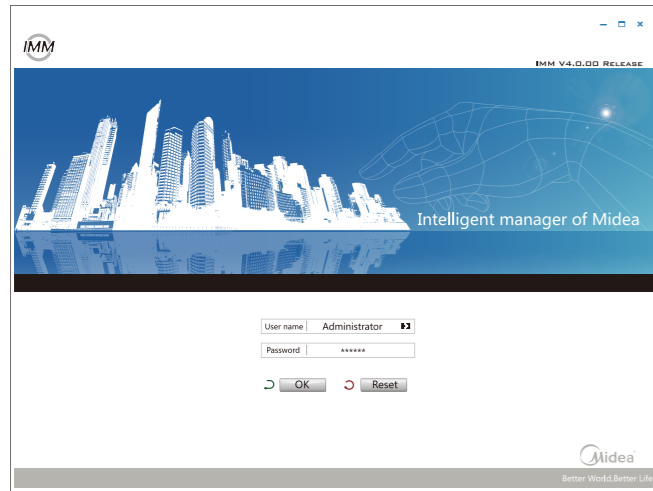

Main interface



## Visual Navigation >>

Allows the floor plan to be imported. Dragging the A/C device to anywhere can locate the A/C quickly, and you can view it to specify the physical location of the A/C. With the visual navigation function, the layout of A/C is showed on the floor plan directly and the running solution is clear.



## Web Access Function >>

With the web access function, a PC, laptop or a smart phone can be used as a remote controller. The function supports up to four users online at the same time. Connects with LAN and WAN so you can monitor and manage the A/C device remotely.

\*WAN access needs to set up the VPN.



## Schedule Management >>

Automatically performs facility start/stop control, switches the operating mode, sets temperatures and enables/disables the remote control according to the present time schedule.

- ◆ Users can set up day/week task for running periodically.
- ◆ Users can choose indoor units and assign task times as required.
- ◆ Except for the conventional setup, the system offers all kinds of energy conservation options.

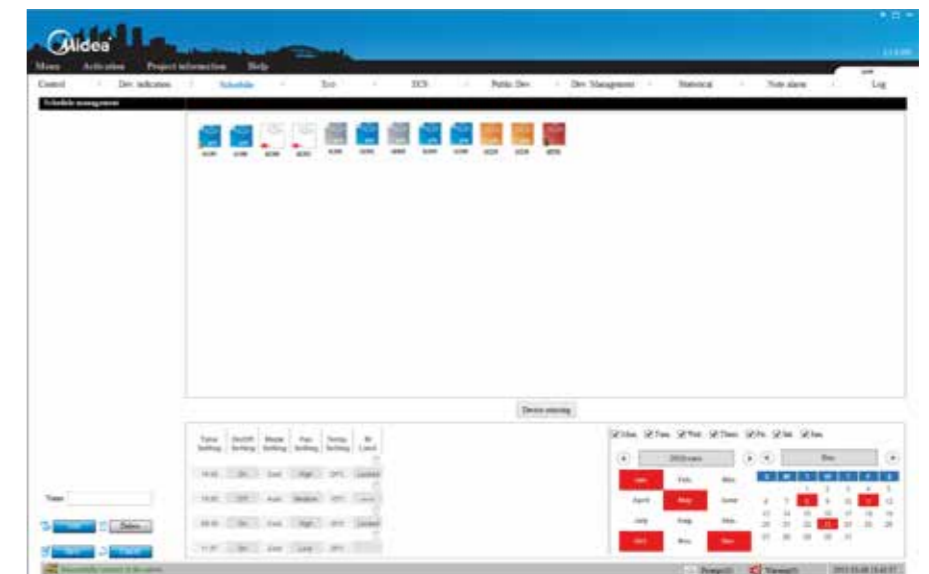



## Electricity Charge Distribution (Patented) >>

- ❖ Provides information on proportional electrical power distribution to optimize electricity consumption management.
- ❖ Uses software to calculate electric power proportional distribution. The software also outputs and saves electricity consumption data for each indoor unit (or group) connected to the intelligent manager.
- ❖ Applies the patented Midea Calculation Method to calculate consumption rates according to the capacity demand based on various parameters: temperature setting, room temperature, running mode, rated HP, public areas, unused rooms, and nighttime use. It outputs this information on a charge calculation sheet to evenly divide power consumption charges among tenants.
- ❖ Electricity charges can be easily divided when billing users for air conditioning power charges; for example, for tenants in a commercial building, offices in a rented building or rooms in a hotel.

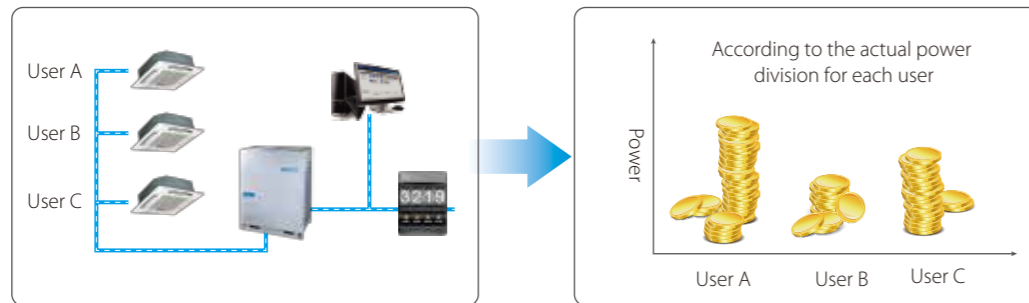

Energy consumption can be divided according to the running time, set temp, return air temp, and refrigerant flow.

## Energy Saving Management >>

Based on a predetermined schedule, the Intelligent Manager executes capacity control and intermittent operations on all air conditioning units to maintain a high comfort index.

User can set a limit on any running unit, any parameter, such as cooling temp., heating temp., fan speed, operation mode, and so on.

- \* 1. Meet with the <Public building energy efficiency management regulations>.
- 2. Matches the corresponding indoor units.

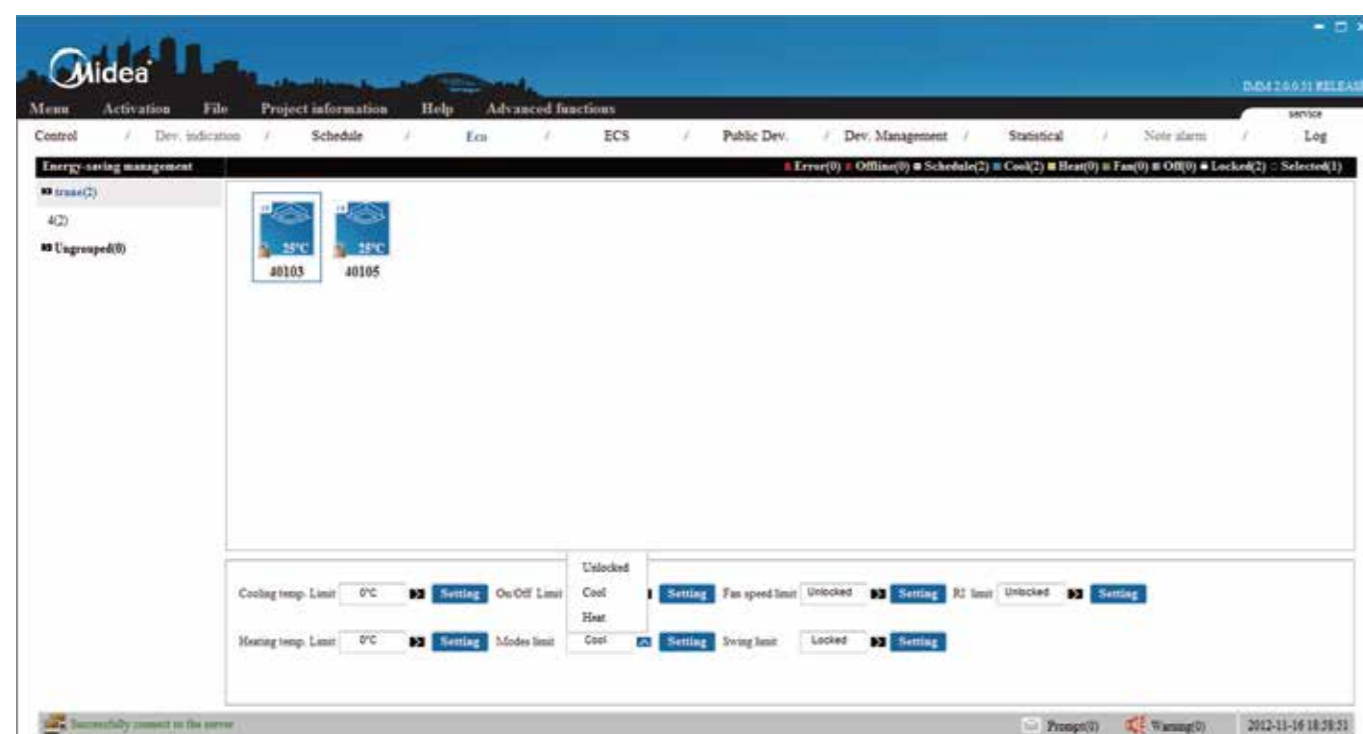

## Automatic & Manual Topology >>

With automatic topology mode and manual topology mode.



Automatic topology

Can topologize automatically between the indoor and outdoor units in the refrigerant system.  
One M-interface gateway can support, up to 4 refrigerant systems, 256 indoor units and 16 outdoor units.



Manual topology

Manually set the topologize method between the indoor and outdoor units in the refrigerant system.  
One M-interface gateway can support, up to 16 refrigerant systems, 256 indoor units and 64 outdoor units.

## Warning Message >>

The system can receive error messages from air conditioning units in more than one building on public phone lines. If a particular factor influences normal operations, the system will send a message to technicians as an early warning.

\*Requires the Midea "SMS Modem" to send automatic warning messages to designated phone numbers.

## Data Management >>

Monitors the operating information of individual indoor units to distribute the power consumption of outdoor units.

Stores operation data on multiple systems and reports it in excel format for visual management.

Uses IMM software to generate tenant reports and help building owners bill for energy use.

## Zone Management >>

Easy to control and manage air conditioners.

Easy to manage the energy charges of public devices.

## Data Backup >>

Double data backup stored on the M-interface and IMM database.

The M-interface gateway automatically backs up power data for 1 or 2 months if a system failure occurs.

Examples: if there is a PC power failure or a system crash, the M-interface will automatically backup the data to the gateway. IMM software also stores running data on the software database.

## Colorful Language Obtained >>

Supports multiple languages. Customers can select their required language.

9 different languages:



## Data Converter

The cloud server controller enables remote control on the VRF system through the Internet.

Smart phones, tablets, laptops, and desktop PCs can serve as a web controller for up to 64 indoor units.

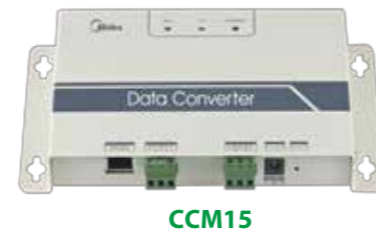

### Network Example >>

Can directly connect to the XYE port of indoor/outdoor units.

Can connect up to 64 indoor units.

CCM03/CCM30 is optional, and can be connected with CCM15 through F1F2E ports.

The system comprises an A/C system, data converter CCM15, router, cloud server and control terminal.

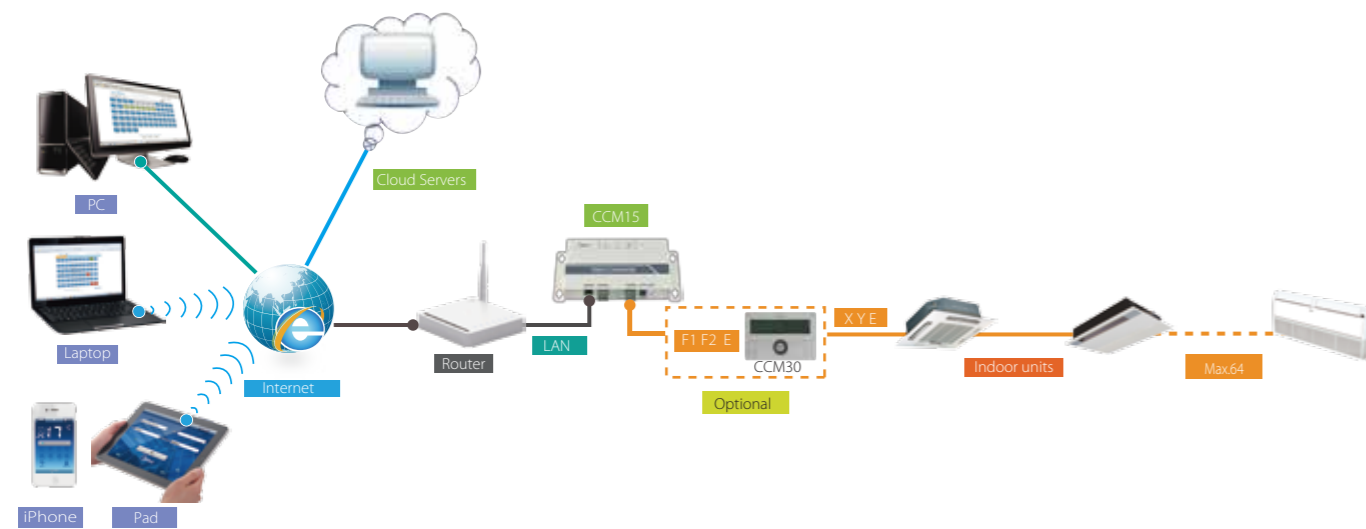

\*If it connects to the XYE ports of the master ODU, the ODU must be set to auto addressing mode.

### Simply Control Interface >>

Software control/ Cloud server control (WEB access).

Click & Operate: the user-friendly interface.

Allows single and group control.

Simplified user control interface.

Color indication and icons makes it easy to recognize unit status.

Includes a full-screen display, and allows temperature adjustment by swiping.



### Weekly Schedule Control >>

Weekly schedule for iPad and Web function.

Multiple sections in each day for a single unit or group.

Automatically performs facility start/stop control, operating mode, and temperature according to the set time schedule.



### Cloud Server Web >>

Query and control a single unit or group.

Weekly schedule setting: can set multiple sections in each day for a single unit or group.

Group user control: you can use the same ID to manage hundreds of CCM15 when you select the As group user button on the login page.

Historical errors: easy service and management with a history error function.

### Intelligent Control >>

The air conditioner can be remote controlled by a phone or tablet.

Query and control the running state of the A/C anytime, anywhere, and schedule queries and actions in advance.

Remotely turn off the air conditioner to avoid wasting power.





**Modbus® Gateway**

**LonWorks® Gateway**

**BMS**

**KNX Gateway**

**BACnet® Gateway**

## What is the BMS? >>

The Building Management System (BMS) (or Building Automation System (BAS)) is a computer-based control system installed in buildings. The BMS monitors the mechanical and electrical equipment such as ventilation, lighting, power, fire, and security. There are four types of common BMS protocols: BACnet, LonWorks, Modbus and KNX.



MD-KNX

## KNX Gateway

Specially designed to allow monitoring and bidirectional control on the parameters and functionality of the Midea air conditioner from KNX installations

### What Is The KNX? >>

KNX (Konnex) starts from 1999. KNX is the only global standard for housing and building control, and has been adopted by 70% of Europe's smart home market.

### Key Features >>

- ❖ Compatible with all Midea VRF products
- ❖ External power is not required and direct connect to the KNX EIB bus
- ❖ Fully KNX interoperable, configuration from ETS
- ❖ Multiple objects for control (different types: bit, byte, characters...)
- ❖ Easy installation and directly connects with one indoor unit through the RS485 bus
- ❖ Directly connects to the KNX bus
- ❖ KNX certification

### Widely Applied >>

Midea KNX protocol gateway can be combined with hundreds of KNX certified products labeled with the KNX trademark in the same working system.

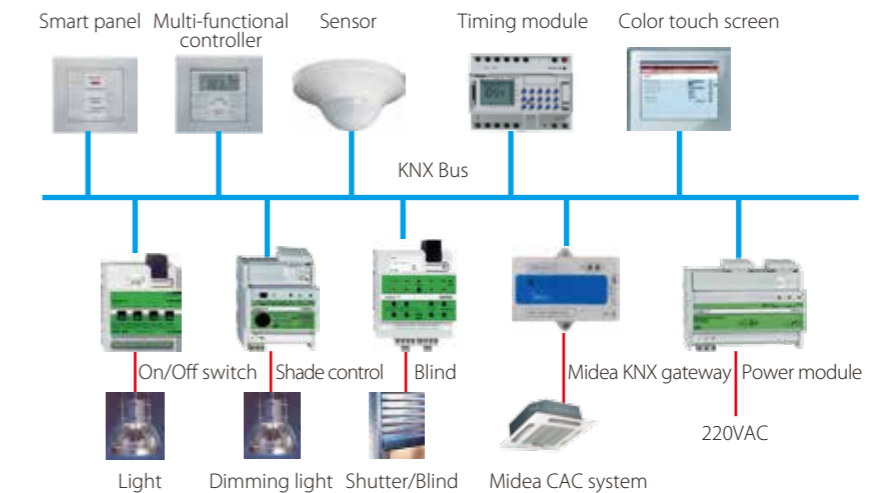

### Electrical Wiring >>

One gateway only can be connected to one indoor unit.  
Can only connect to the XYE port of the indoor unit.

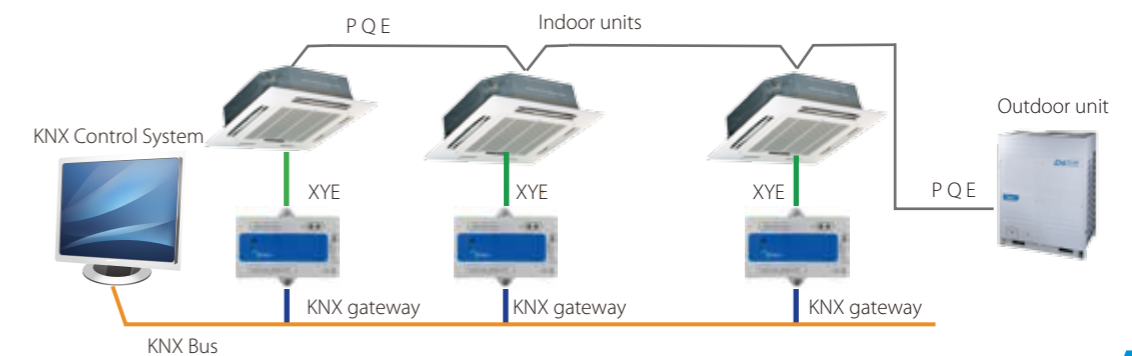





MD-CCM08

## BACnet® Gateway

Integrated Control System for Seamless Connection between VRF and BMS Systems

### What is the BACnet? >>

BACnet is a communications protocol for building automated control networks. BACnet was designed to allow building automation and control systems for applications to communicate; e.g., heating, ventilation, air conditioning control, lighting control, access control, and fire detection systems and their associated equipment.

### Key Features >>

- ❖ Precise and efficient monitoring and control of the Midea VRF system
- ❖ Connect up to 256 indoor units or 128 outdoor units to the BMS
- ❖ Choose whether or not to connect to the BMS
- ❖ Built-in WEB function
- ❖ BTL certification

#### ● Controlling

- Operation mode setting
- Temperature setting
- Fan speed setting
- Swing running for web
- Lock remote controller

#### ● Monitoring

- Operation mode status report
- Set temperature status report
- Fan speed status report
- RC locking status
- Online quantity
- Timer status
- Error status
- Room temperature display

\*For more information, refer to the product object table.

### Monitoring Units Online >>

MD-CCM08 allows users to track units' running status and change their running parameters on Internet Explorer for maximum control convenience.

### Quick & Easy Installation >>

Each port can connect to IDU/ODU XYE ports or outdoor units' K1K2E ports.  
Each port can also connect to one CCM03 or one CCM02 through F1F2E ports.

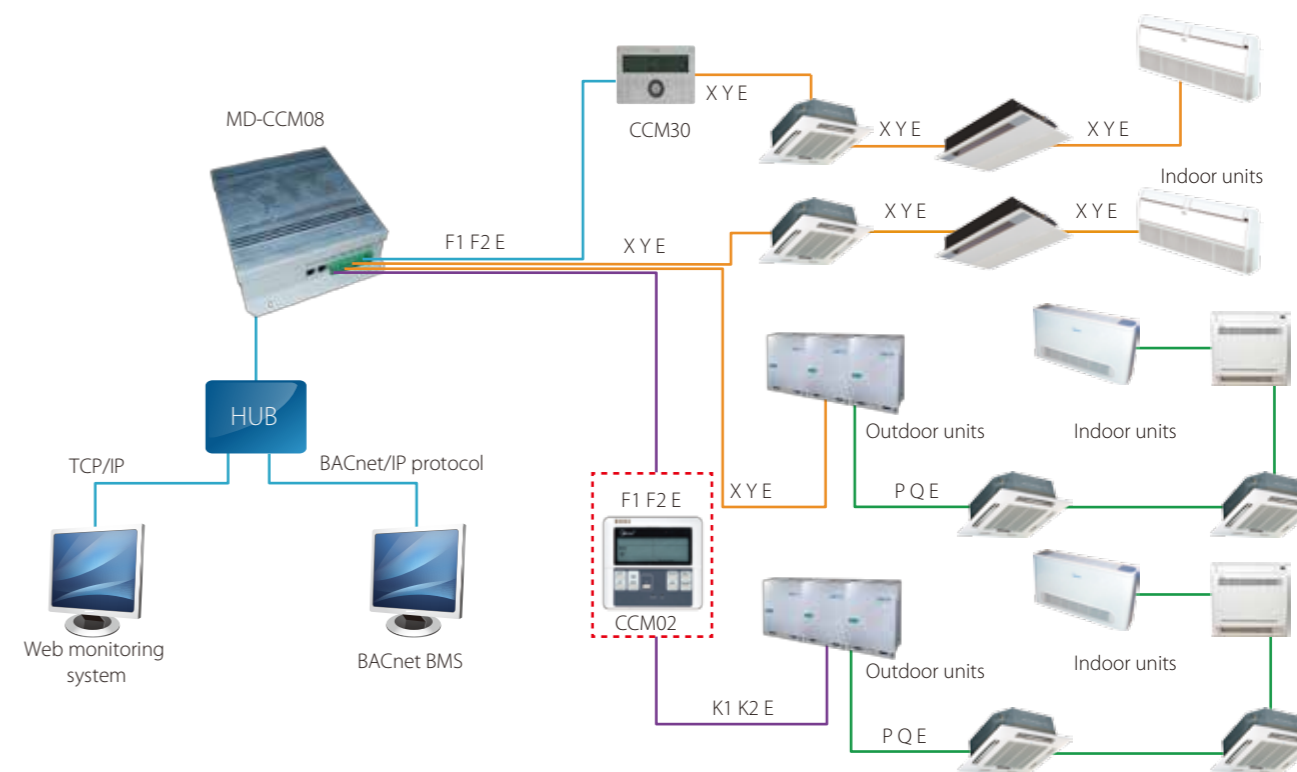

\*If it connects to XYE ports of the master ODU, the ODU must be set to auto addressing mode.

### Wide Compatibility >>

CCM08 adapts very well to the BMS

	Company	BMS software	Brand
1	SIMENS	APOGEE	
2	TRANE	Tracer Summit	
3	Honeywell	Alerton	
4	Schneider	Andover	
5	Johnson	METASYS	

### Specifications

Model	MD-CCM08
Power supply	AC 220V~50/60Hz
Dimensions (HxWxD)( mm)	319x251x61



LonGW64

## LonWorks® Gateway

Open network integration of VRF Monitoring and control functions into LonWorks networks

### What is the LonWorks? >>

LonWorks (local operating network) is a networking platform specifically created to address the needs of control applications. The platform is built on a protocol created by Echelon Corporation for networking devices over media such as twisted pairs, power lines, fiber optics, and RF.

LonWorks networks are recognized worldwide as the de facto standard within the building control industry. LonWorks is used to automate various functions within buildings; e.g., energy management, fire / life / safety lighting and HVAC.

### Key Features >>

- ❖ Connect to use LonWorks® protocol and Midea air conditioner protocol
- ❖ Compliance with LonMark protocol enables the management and control of A/C system
- ❖ Control various types of equipment from the customer's own PC
- ❖ Connect up to 64 indoor units to the BMS
- ❖ Option for large projects
- ❖ Easy and fast installation

#### ● Controlling

- On/Off command
- Operation mode setting
- Temperature setting
- Fan speed setting

#### ● Monitoring

- Operation mode status report
- Set temperature status report
- Fan speed status report
- Online/offline status
- Online quantity
- Error status
- Room temperature display

\*For more information, refer to the product network's variable charts.

### Network Example >>

- ❖ Connection method 1: suitable for all air conditioning systems and can connect up to 64 indoor units.

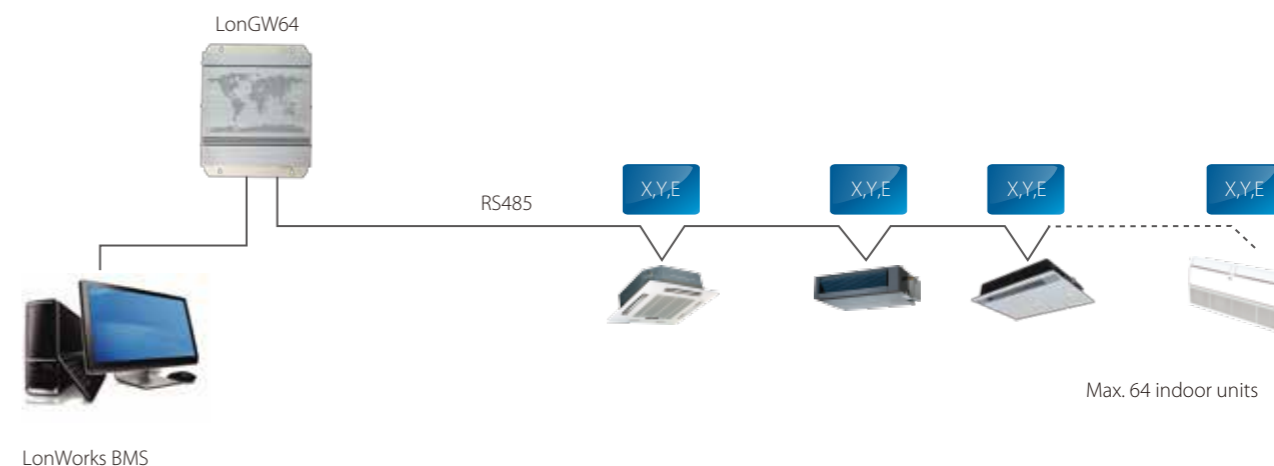

- ❖ Connection method 2: only suitable for the V4 plus system and can connect up to 64 indoor units.

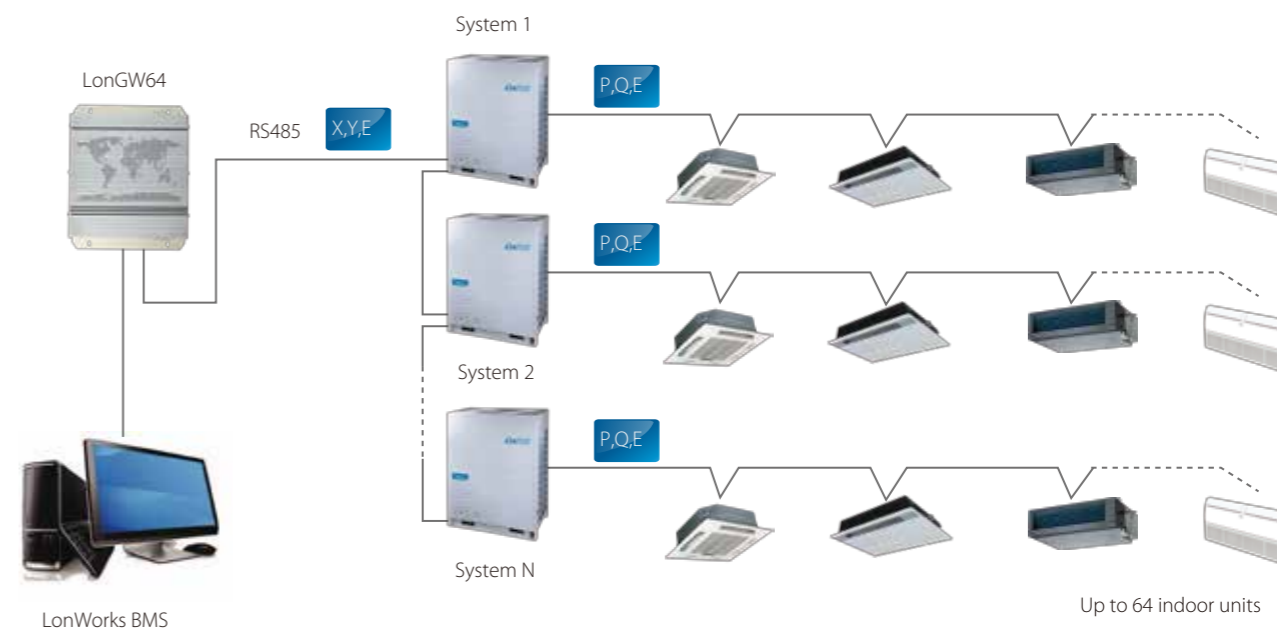

\*If it connects to X,Y,E ports of the master ODU, the ODU must be set to auto addressing mode.

### Specifications

Model	LonGW64/E
Power supply	AC 220V~50/60Hz
Dimensions (HxWxD)( mm)	319x251x61



**CCM-18A/N**  
**CCM-18A/N-U**

## Modbus® Gateway

Integrated Control System for Seamless Connection between VRF and BMS Systems

### What is the Modbus? >>

Modbus is a serial communications protocol originally published by Modicon (now Schneider Electric) in 1979 for use with its programmable logic controllers (PLCs). Modbus is often used to connect a supervisory computer with a remote terminal unit (RTU) in supervisory control and data acquisition (SCADA) systems.

### Key Features >>

- ❖ Supports Modbus protocol networks
- ❖ Bridges the Midea central A/C system to the BMS
- ❖ Built-in WEB server function
- ❖ Connect to the BMS system through TCP/IP or RTU
- ❖ Two models: CCM-18A/N & CCM-18A/N-U  
Model CCM-18A/N-U can only connect up to 16 indoor units.  
Model CCM-18A/N can connect up to 64 indoor units and 4 outdoor units.

\*The four outdoor units must be in the same system

#### ● Controlling

- Operation mode setting
- Temperature setting
- Fan speed setting

#### ● Monitoring

- Operation mode status report
- Set temperature status report
- Timer status
- Fan speed status report
- RC locking status
- Online/offline status
- Error status
- Room temperature display

\*For more information, refer to the Modbus product mapping table.



### Network Example >>

1) TCP connection method

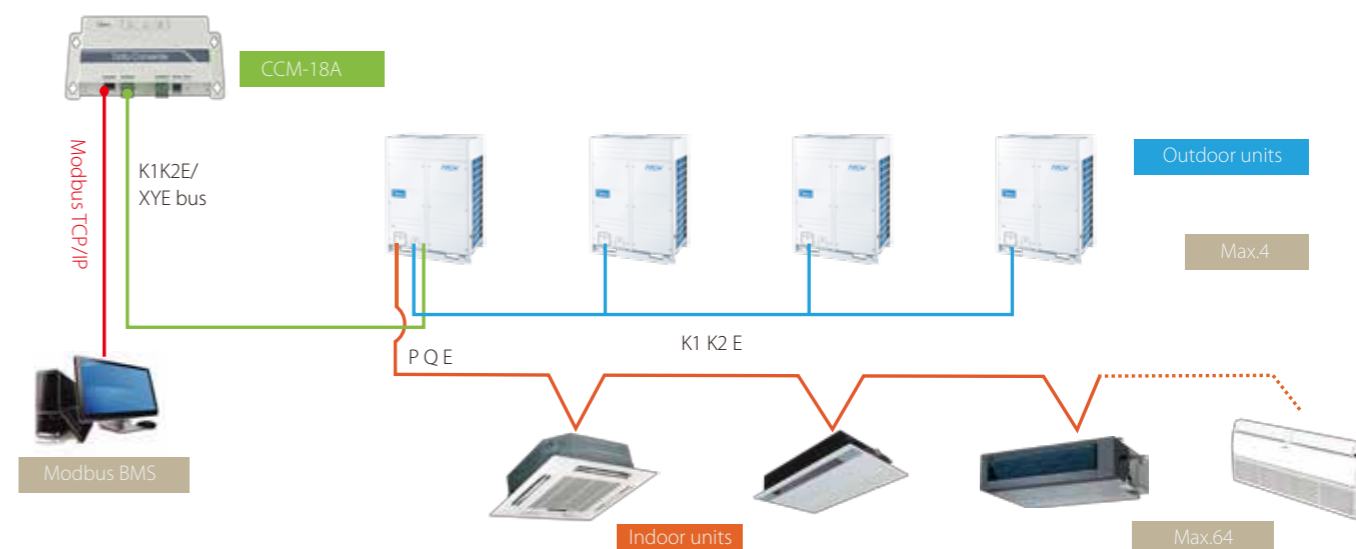

2) RTU connection method

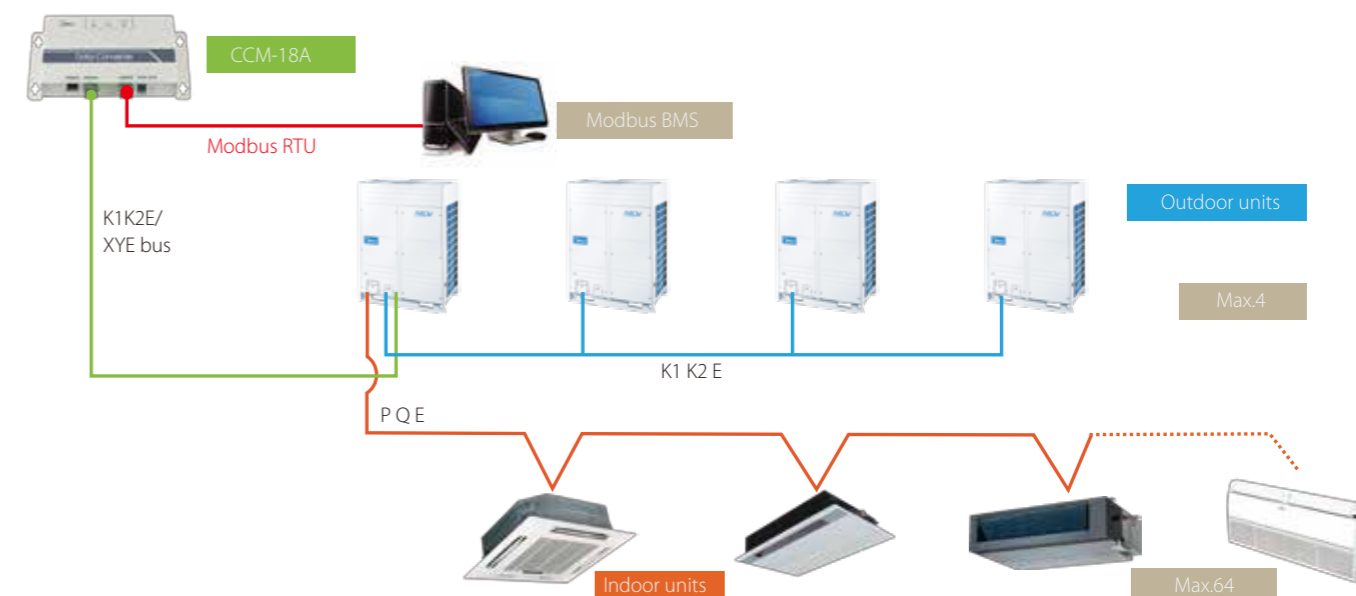

\*1. If it connects to XYE ports of the master ODU, the ODU must be set to auto addressing mode.

2. XYE and K1K2E must be connected hand by hand.

### Specifications

Model	CCM-18A
Dimensions (HxWxD)( mm)	319x251x61
Power supply	AC 220V~50/60Hz



## Accessories



## Hotel Key Card Interface Module

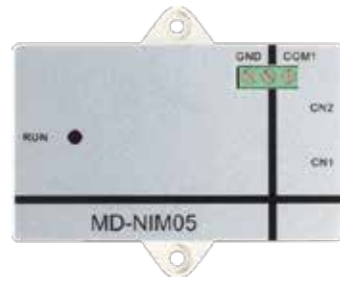

MD-NIM05/E



MD-NIM05B/E

## Key Features &gt;&gt;

- ❖ MD-NIM05 is specially designed for hotel guest rooms, restaurants and so on. It works with a hotel card system
- ❖ Simple, compact, and easy to operate; suitable for hotel rooms
- ❖ Key card cooperates with wired controller to control the A/C
- ❖ Eliminates the need for high voltage power, making the device safe and reliable
- ❖ Includes a build-in auto-restart function
- ❖ Remote controller or wired controller can control indoor units
- ❖ Two types are available: MD-NIM05/E and MD-NIM05B/E

## Application Example &gt;&gt;

The unit can be turned on or off when inserting or removing the key card.

When the key card is in place, the air conditioner is activated. When the key card is removed, the system can remember the previous setting and stop operation. If the key card is reinserted, the unit enters standby or runs in the same state as the previously. It can stop cooling an unoccupied room to save energy.

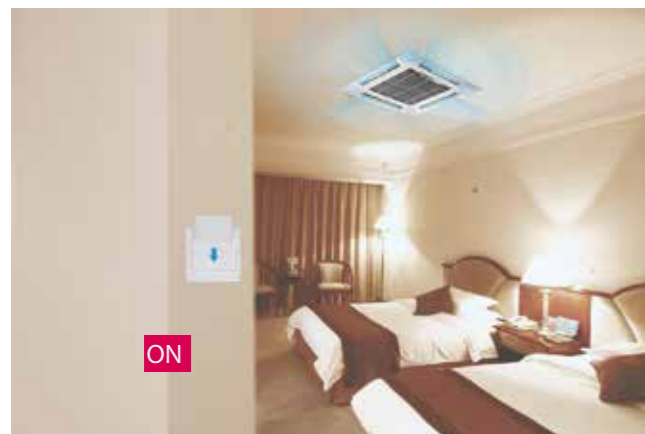

## Installation Example &gt;&gt;

Easy installation and remote controller or wired controller can control indoor units.

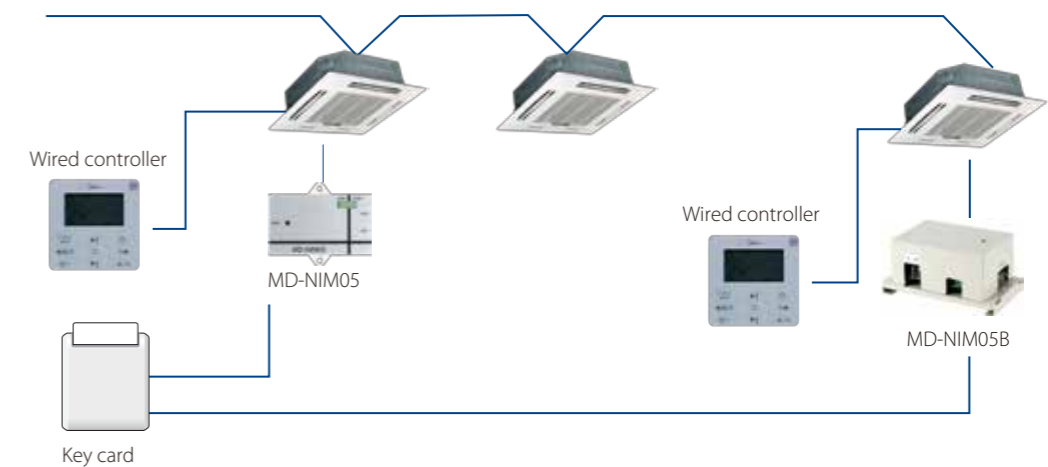

## Electrical Wiring &gt;&gt;

For MD-NIM05/E, users need to buy a high voltage relay for installation.

For MD-NIM05B/E, it can be directly connected to the hotel card-insert system (AC 220V) without a high voltage relay.

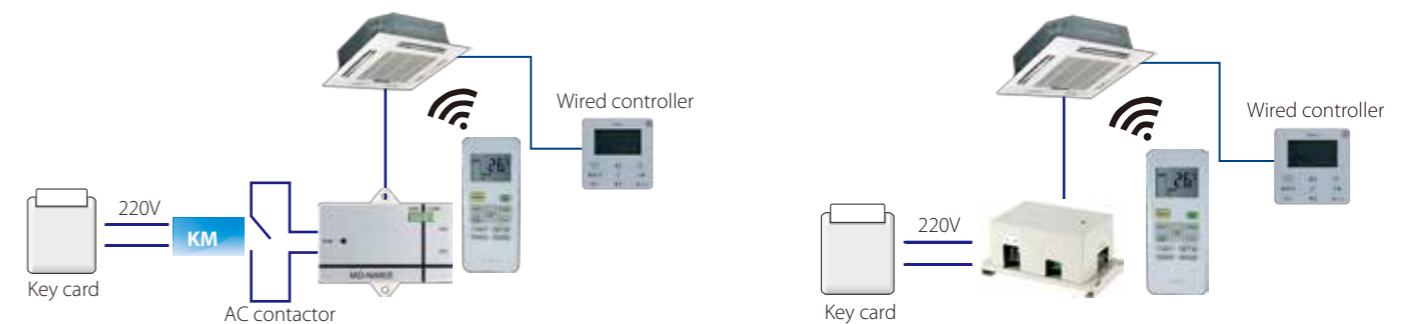

## Specifications

Model	MD-NIM05/E	MD-NIM05B/E
Dimensions (HxWxD) (mm)	15.5x86x72.8	87x150x70
Power (V)	DC 5V (Supplied by indoor unit)	AC 220V

## Infrared Sensor Controller

Infrared sensors can induct human activities in certain areas. Indoor units will be automatically turned on or off by sensing if the room is unoccupied. It is suitable for hotels, offices, conference rooms, residences, etc.

- ❖ Automatically adjusts the room environment.
- ❖ Automatically extends the shut down time to avoid frequent ON/OFF.
- ❖ Stylish appearance accommodates itself to different buildings.



MD-NIM09

### Accurate & Comfortable Sensor >>

It detects motion and automatically starts the air conditioner if motion is detected. This function will save energy since it minimizes unnecessary energy usage by powering off when the area is empty. The infrared sensor can be installed on the ceiling or wall of well-used areas.



Install on the ceiling

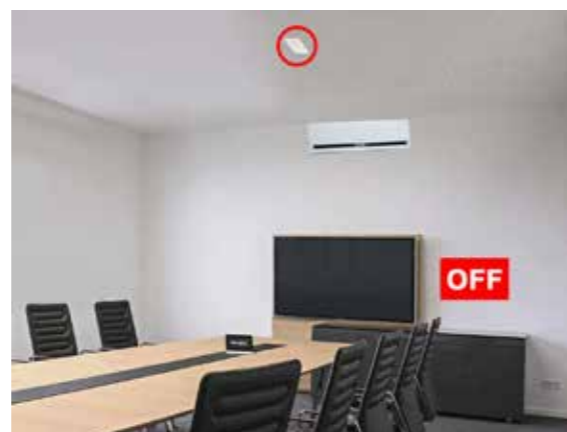

### Installation Example >>

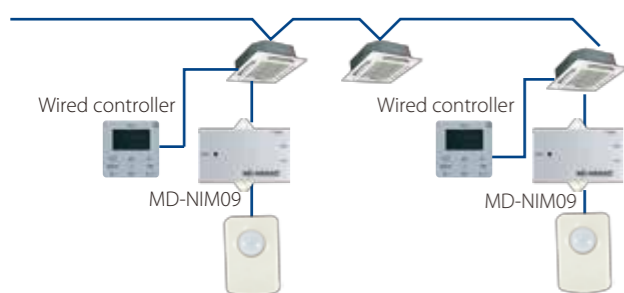

Remote controller or wired controller can control indoor unit.

### Electrical Wiring >>

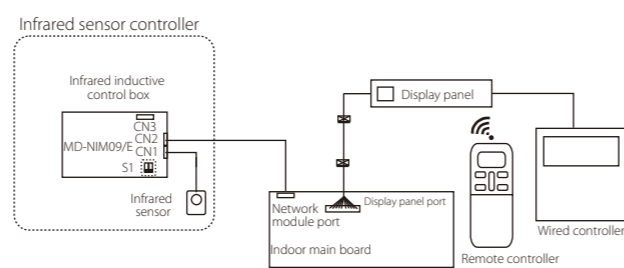

### Specifications

Model	MD-NIM09
Dimensions (HxWxD)(mm)	Sensor part: 46x30x25.6, Control box: 86x72.8x15.5
Power	DC 5V (Supplied by indoor unit)

## 3-Phase Protector

HWUA/DPB71CM48

Detects power status and takes protective action to stop the compressor from being damaged.

Automatically distinguishes abnormal power supply conditions and automatically recovers.



HWUA DPB71CM48

### Excellent Reliability >>

The protector protects the entire system from power supply problems, and auto restarts after recovery.

### Specifications

Model	With over/under voltage function				Without over/under voltage function
	HWUA	DPA53CM23	HWUA	DPB71CM48	DPA51CM44
Power supply	220~480V-3N 50/60Hz	208~480V-3N 50/60Hz	220~480V-3N 50/60Hz	380~480V-3N 50/60Hz	208~480V-3N 50/60Hz
Temp. range	-20°C~50°C	50Hz: -20°C~60°C 60Hz: -20°C~50°C	-20°C~50°C	-20°C~50°C	50Hz: -20°C~60°C 60Hz: -20°C~50°C
Rated operational power	2.9 VA	7 VA	2.9 VA	13 VA	13 VA
Over voltage	12%	12%	18%	18%	/
Under voltage	-12%	-12%	-12%	-12%	
Phase imbalance	8%	/	8%	8%	
Dimensions(WxHxD)(mm)	90x69x35	81x67.2x17.5	90x69x35	81x67x35	81x67.2x17.5

## Digital Power Ammeter

Calculates power consumption.

Does not need adjusting after long-term use.

Corresponds one outdoor unit to one digital power meter.



DTS634  
DTS636

### Low Power Consumption >>

The digital power meter consumes minimal energy.

Voltage circuit: less than 2W/10VA

Current circuit: less than 2.5VA

### Indications & Installation >>

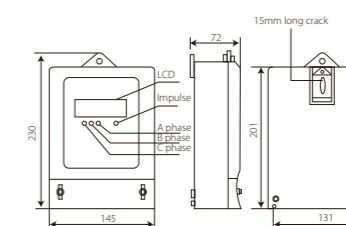

The digital power meter is tested after manufacture so it can be immediately deployed and used on-site. The LED indicators and installation schematic are shown in the figure on the left.

### Specifications

Model	DTS634/DTS636
Dimensions (HxWxD)(mm)	230x145x72
Power (V)	200V-500V(50/60Hz)

## Indoor Unit Group Controller



**KJR-150A**

### Simple Design >>

KJR-150A is an indoor group controller designed specifically for V4 plus indoor units.

It can connect up to 16 indoor units through XYE ports.

With a display panel connected to KJR-150A, signals from a wired controller and remote controller can control a group of indoor units simultaneously. All indoor units will run at the same setting parameters. You can also control indoor units separately in each room by remote controller. The indoor units will run as previously set.

### System Wiring Diagram >>

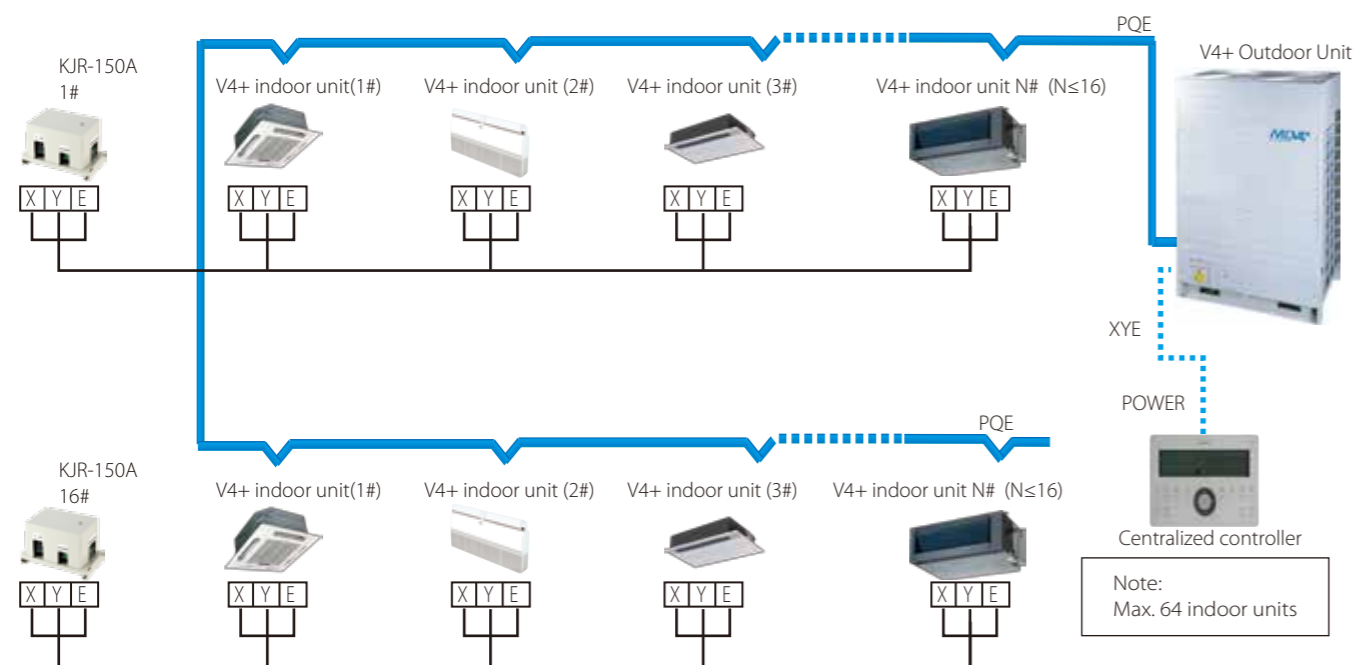

\* If you need to use a centralized controller, you can connect to the XYE from an outdoor unit.

### Specifications

Model	KJR-150A
Dimensions (HXWXD)(mm)	85X150X70
Power (V)	198-242V(50/60Hz)

## Remote Alarm Controller



**KJR-32B**

### Simple Design >>

KJR-32B is specially designed for engineering applications. It does not display the ODU's working parameters. However, it can connect to the alarm device when the ODU is working abnormally, in which case the RUN light will flash.

### Specifications

Model	KJR-32B
Dimensions (HxWxD)(mm)	85X150X70
Power (V)	198-242V(50/60Hz)

## Network Electricity Distribution Module



**MD-NIM10**

### Simple Design >>

- ❖ External contact interface module
- ❖ Designed specifically for Mini VRF
- ❖ Provides the OAE ports for Mini VRF to connect with the IMM network control system, and distributes electricity across the network.

### Wiring Diagram >>

OAE ports: connects to the OAE port of the ammeter.

PQE ports: connects to the PQE port of the outdoor unit.

Each port on M-interface gateway can only be connected with one MD-NIM10 through K1K2E ports.





## AHU Control Box



**AHUKZ-01A**  
**AHUKZ-02A**  
**AHUKZ-03A**

**AHUKZ-01B**  
**AHUKZ-02B**  
**AHUKZ-03B**

### Introduction >>

AHU Kit can be used to connect VRF outdoor units with DX AHU or other brand indoor units with AC fan motor. A Series and B Series are supplied. These can connect with the Midea VRF System (except V4+R& V5 Series). The A Series is an independent control box. For the B Series, up to four control boxes can be combined. The capacity reaches up to 224kW (80HP), and it's easy to create a solution for large projects.

### Wiring Example >>

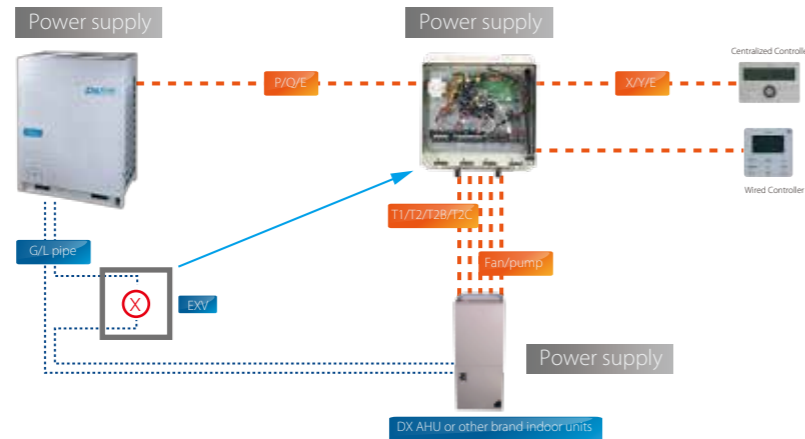

### Specifications

Model	AHUKZ-01A/AHUKZ-02A/AHUKZ-03A
	AHUKZ-01B/AHUKZ-02B/AHUKZ-03B
Dimensions(HxWxD)(mm)	335x375x150
Power (V)	220-240V~ 50Hz 208-230V~ 60Hz

## Midea Outdoor Unit Diagnosis Software

Display the outdoor units' real-time running conditions.  
Automatically outputs running status charts.  
Supports V3, V4, V4+, D3, D4, V4+S and V4+R outdoor units.



MCAC-DIAG/E

### Wiring Diagram >>

The diagnostic software applies to K1, K2, E of the outdoor units. The corresponding wiring diagram is shown in the figure on the right.

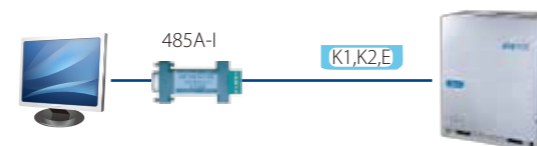

### Recommended Config

Operating system	WIN XP SP4/WIN 7
CPU	Pentium 4 2G or above
HDD	30G free space
Interface port	RS-232 terminal

## Selection Software

To meet consultants' and distributors' requirements, Midea has developed an advanced design automation tool that can be used in AutoCAD-based CAD version or Windows-based Sales version. The software provides quick and convenient selectable options for users, supports multiple languages, and greatly improves the selection process.

### Windows Version >>

- Load calculation: provides two calculation methods (detailed room load calculation and rough load calculation).
- Indoor & outdoor units: choose from versatile indoor units and different outdoor units.
- Piping drawing: displays the detailed layout of the A/C system and the parameters for piping and branch distributors.
- Controller selection: provides a selection of controllers for indoor units and outdoor units, including wireless and remote controllers for indoor units.
- Report output: outputs a comprehensive selection report as a Word or PDF document.

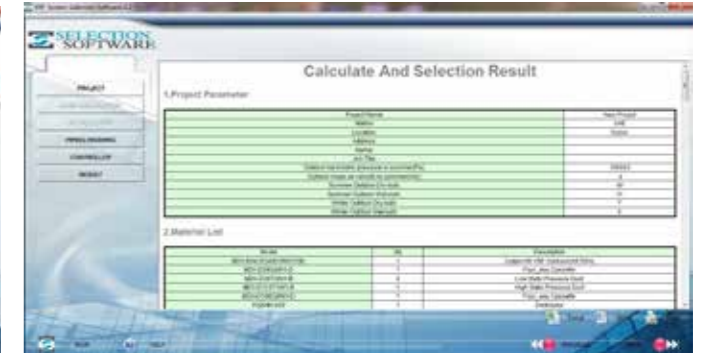

### CAD Version >>

- AutoCAD add-on software
- Automatic Calculation: refrigerant & drain pipe size
- Automatic Selection: distributor kit & branch joint
- System Check: installation regulations & adding refrigerant
- Automatic Report: piping installation diagram, equipment list & quotation

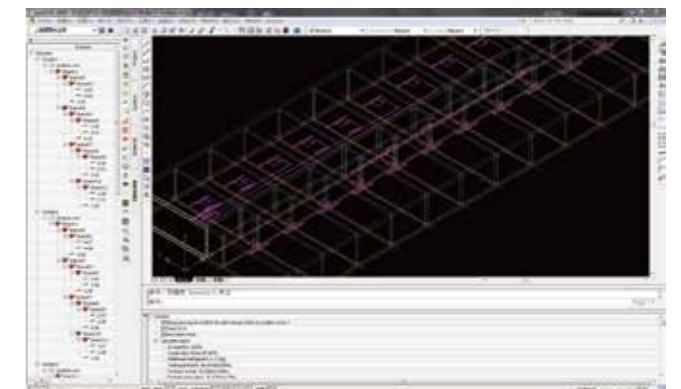
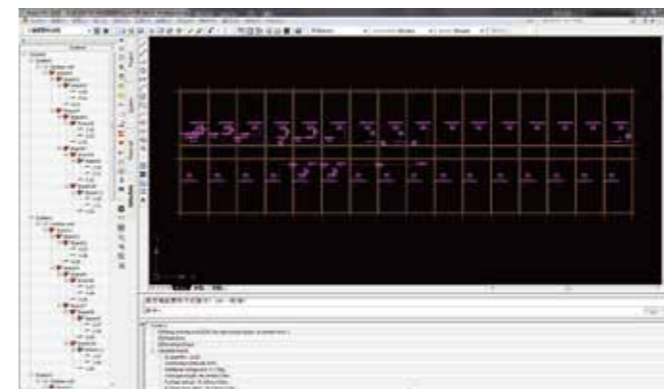

## APP Application

### Midea CAC News APP >>

Midea CAC News APP has been developed to share E-news, new product information, training information and product catalogs.



Midea CAC News Application



iOS Version

### Midea CAC After-service APP >>

Midea CAC After-service APP is very useful for engineers who serve for Midea commercial air conditioner. It will be very convenient to do the commissioning, refrigerant charge and troubleshooting.

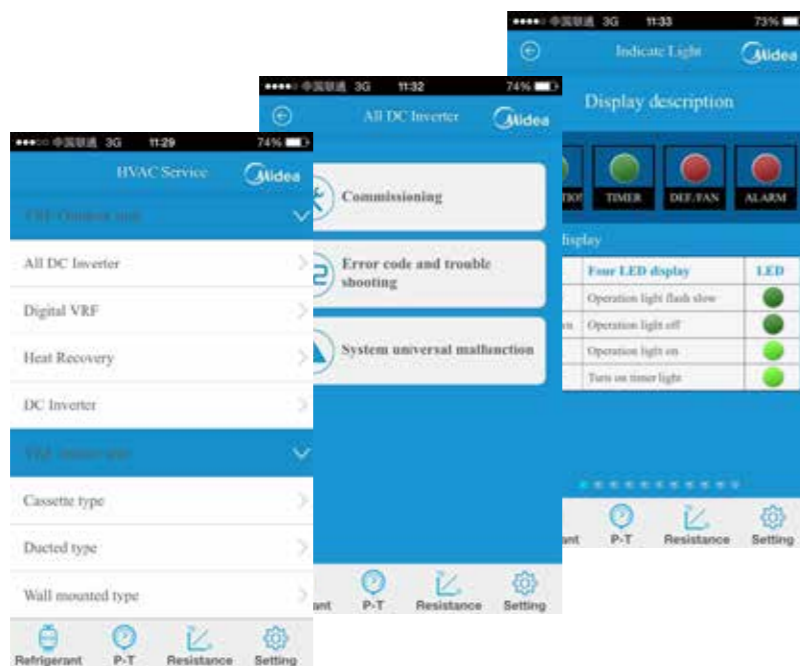

Midea CAC After-service Application



Android Version



iOS Version

## HRV-Heat recovery ventilator

Larger air supply rate  
enhanced heat exchange efficiency  
enhanced energy saving property >>

The heat recovery ventilator (HRV) can reclaim heat energy lost through ventilation and reduce the room temperature fluctuation caused by ventilation process. By utilizing the most advanced technology and technics, Midea HRV has extremely good performance. The heat exchanged core is made of special paper processed with chemical treatment, which could realize better temperature and humidity control of the room environment. Temperature exchange efficiency is above 65% and enthalpy exchange efficiency between 50-65%.

### Model Names

HRV-200 HRV-500  
HRV-300 HRV-800  
HRV-400 HRV-1000



HRV-1500  
HRV-2000

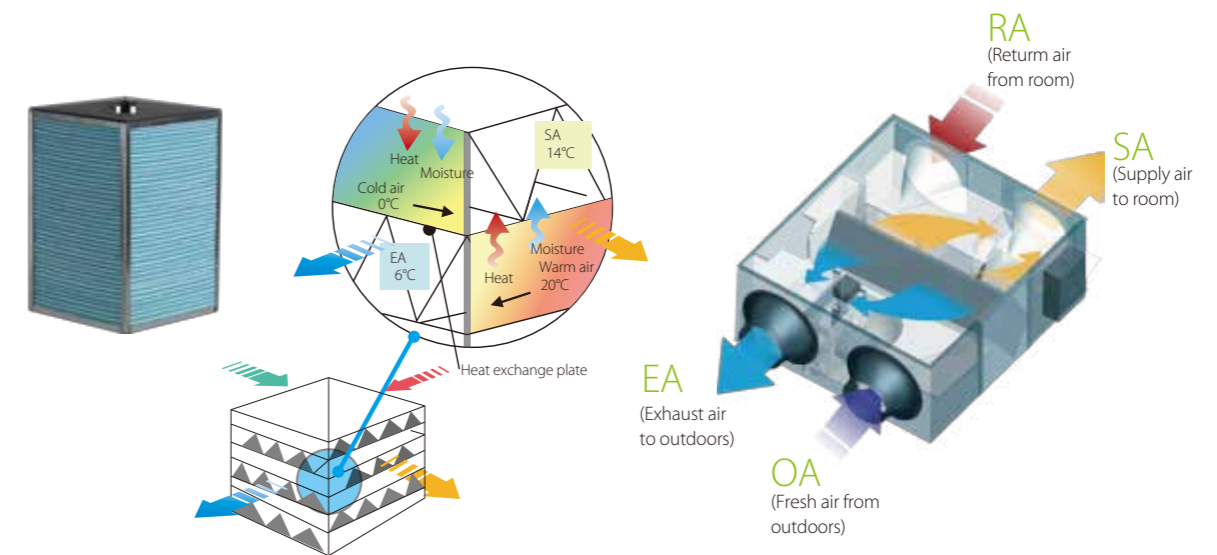

### Low noise >>

Sound proof material is used to guarantee quiet operation.

### Compact design, flexible installation and easy maintenance >>

With a min. height of only 10-25/64in.(264mm) and 50lbs(23kg) weight, the unit provides best convenience and possibility for installation in limited spaces.

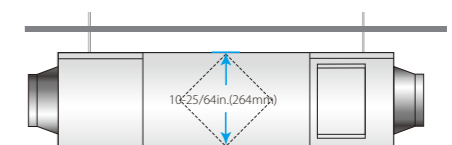



## Multi-modes for different situations >>

### Heat exchange mode

When air flow formed by the fans goes through the heat exchanged core in cross way, due to temperature difference between two channels of the core, thermal transmission happens naturally.

In summer days, high temperature outdoor air gets cooled by indoor exhaust air; in winter, low temperature outdoor air gets heated by indoor exhaust air. So the energy contained in exhaust air can be reclaimed and energy efficiency gets improved.

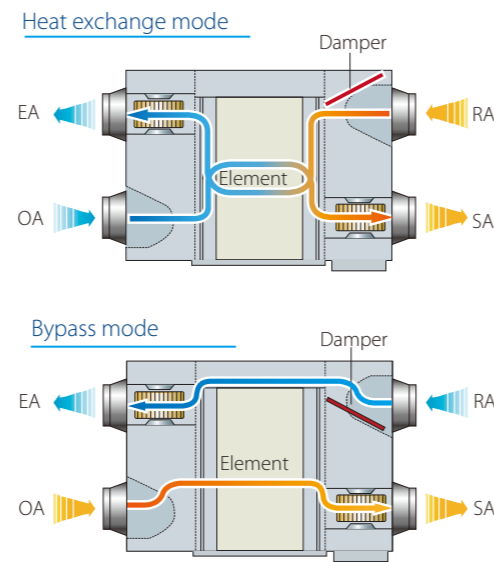

### Bypass mode

In mild climate areas or seasons, when temperature and humidity level difference between indoor and outdoor is small, the unit works as conventional ventilation fan. Both supply fan and exhaust fan works at the same speed (Hi/mid/low/auto).

### Air supply mode

It is one kind of bypass mode with air supply fan speed higher than exhaust fan speed. It can be used in mild climate area where large amount fresh air is needed.

### Exhaust air mode

It is also one kind of bypass mode with exhaust fan speed higher than air supply fan speed. It can be used in mild climate area where large amount exhaust air needs to be expelled.

### Auto mode

The controller chooses heat exchange mode or bypass mode according to the temperature difference between outdoor and indoor temperature. Both the two fans work at low speed.

## Flexible control >>

Interlocking control with other indoor units by controller is possible.

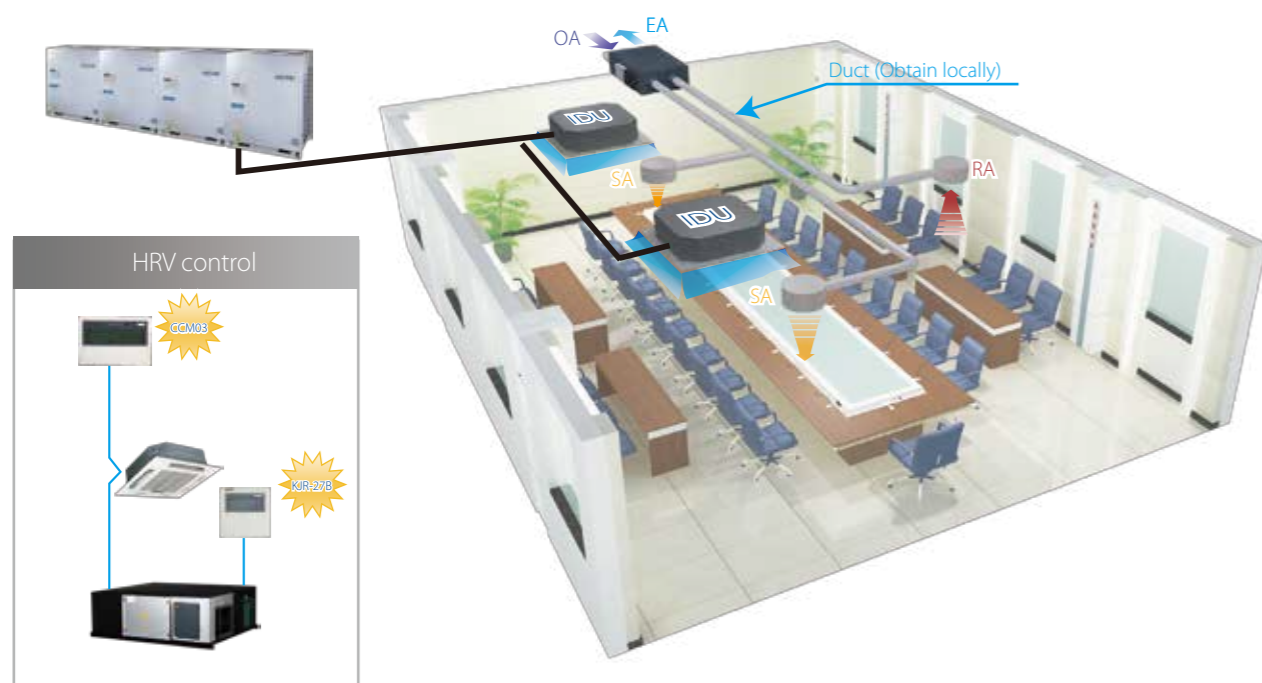

## Specifications

Sale Model			HRV-200	HRV-300	HRV-400	HRV-500	HRV-800	HRV-1000	HRV-1500	HRV-2000	
Power supply		V-Ph-Hz	220V-1Ph-50Hz						380V-3Ph-50Hz		
Cooling	Temp. efficiency	High	%	55	55	55	55	55	55	55	
		Medium	%	55	55	55	55	55	55	/	
		Low	%	60	60	60	60	60	60	/	
	Enthalpy efficiency	High	%	50	50	50	50	50	50	50	
		Medium	%	50	50	50	50	50	50	/	
		Low	%	55	55	55	55	55	55	/	
Heating	Temp. efficiency	High	%	60	60	60	65	65	65	65	
		Medium	%	60	60	60	65	65	65	/	
		Low	%	65	65	65	70	70	70	/	
	Enthalpy efficiency	High	%	55	55	60	60	60	60	60	
		Medium	%	55	55	60	60	60	60	/	
		Low	%	60	60	65	65	65	65	/	
Indoor fan	material		ABS						metal		
	Type		Centrifugal fan								
	Diameter	mm	Φ154	Φ194	Φ194	Φ203	Φ245	Φ245	Φ234	Φ254	
	Height	mm	102	100	100	151	203	203	253	285	
Motor output	W	20	40	80	120	360	360	450	450		
Indoor static pressure and air flow	High	Pa/m <sup>3</sup> /h	75/200	75/300	80/400	80/500	100/800	100/1000	160/1500	170/2000	
	Medium	Pa/m <sup>3</sup> /h	58/200	60/300	65/400	68/500	82/800	85/1000	/	/	
	Low	Pa/m <sup>3</sup> /h	35/150	40/225	43/300	45/375	54/600	58/750	/	/	
Sound pressure level	Heat exchange model	High	dB(A)	27	30	32	35	39	40	51	
		Medium	dB(A)	26	29	31	34	38	39	/	
		Low	dB(A)	20	23	25	28	32	33	/	
	Bypass model	High	dB(A)	28	31	33	36	40	41	52	
		Medium	dB(A)	27	30	32	35	39	40	/	
		Low	dB(A)	22	25	27	30	34	35	/	
Net dimension (LxWxH)		mm	866x655x264	944x722x270	944x927x270	1038x1026x270	1286x1006x388	1286x1256x388	600x1270x540	650x1470x540	
Packing size (LxWxH)		mm	960x770x445	1020x810x452	1020x1020x452	1120x1120x452	1380x1100x573	1400x1370x573	710x1410x720	760x1610x720	
Net/Gross weight		kg	23/40	26/44	31/52	41/64	62/88	79/110	163/224	182/247	
Connection wiring	Power wiring	mm <sup>2</sup>	2x2.5	2x2.5	2x2.5	2x2.5	2x2.5	2x2.5	4x2.5	4x2.5	
	Signal wiring	mm <sup>2</sup>	3x0.75	3x0.75	3x0.75	3x0.75	3x0.75	3x0.75	3x0.75	3x0.75	
Controller			Wired controller								
Fresh air	Fresh Air Diameter	mm	Φ144	Φ144	Φ144	Φ194	Φ242	Φ242	346x326	346x326	
	Air drop	Pa	75	75	80	80	100	100	160	170	
Operating temperature range		°C	-7~43 DB, 80% RH or less								

Note:

1. For the units model of HRV (200-1000), there are 3-speed adjustable air volume (Hi, Med, Low), but for the units model of HRV (1500-2000), there are only 1-speed which cannot be adjusted.

2. Sound level is measured at 1.4m below the center of the body in an anechoic chamber.

3. Temperature Exchange Efficiency is the mean value between cooling and heating.

4. Efficiency is measured under the following conditions:

\* Cooling Condition: Air Exhaust Temp. 27°C DB, 19.5°C WB, Fresh Air Temp. 35°C DB, 28°C WB.

\* Heating Condition: Air Exhaust Temp. 21°C DB, 13°C WB, Fresh Air Temp. 5°C DB, 2°C WB.



# Branch Pipe

## Branch joints of two-pipe refrigerant system

Model	Appearance	Model name	Packing Size (mm)/ Gross Weight (kg)	Description
Branch joint for 410A outdoor unit		FQZHW-02N1D	255×150×185/1.5	For two outdoor units connection
		FQZHW-03N1D	345×160×285/3.4	For three outdoor units connection
		FQZHW-04N1D	475×165×300/4.8	For four outdoor units connection
Branch joint for 410A indoor unit		FQZHN-01D	290×105×100/0.4	A* < 16.6kW
		FQZHN-02D	290×105×100/0.6	16.6 ≤ A* < 33kW
		FQZHN-03D	310×130×125/0.9	33kW ≤ A* < 66kW
		FQZHN-04D	350×180×170/1.5	66kW ≤ A* < 92kW
		FQZHN-05D	365×195×215/1.9	92kW ≤ A*

A\*:The total capacity of indoor units which is connected to this branch joint

## Branch joints of three-pipe refrigerant system

Model	Appearance	Model name	Packing Size (mm)/ Gross Weight (kg)	Description
Branch joint between outdoor unit		FQZHW-02SB	272×167×232/2.2	For two outdoor units connection
		FQZHW-03SB	472×157×312/5.0	For three outdoor units connection
		FQZHW-04SB	745×160×335/7.5	For four outdoor units connection
Branch joint between MS unit and outdoor unit		FQZHN-01SB	257×127×107/0.8	A* < 16.6kW
		FQZHN-02SB	287×137×107/0.9	16.6 ≤ A* < 33kW
		FQZHN-03SB	297×167×177/1.4	33kW ≤ A* < 66kW
		FQZHN-04SB	372×197×187/2.3	66kW ≤ A* < 92kW
		FQZHN-05SB	432×222×227/3.3	92kW ≤ A*

Branch joint between MS unit and indoor unit

FQZHN-01D 290×105×100/0.4 A\* < 16.6kW

A\*:The total capacity of indoor units which is connected to this branch joint

# Dimensions

## Outdoor branch joints

Branch model	Gas side joints	Liquid side joints
FQZHW-02N1D		
FQZHW-03N1D		
FQZHW-04N1D		

## Indoor branch joints

Branch model	Gas side joints	Liquid side joints
FQZHN-01D		
FQZHN-02D		
FQZHN-03D		
FQZHN-04D		
FQZHN-05D		